

## Chip EMI Filters

Type: **EXCCT**

**Discontinued**



### ■ Features

- Rated current (2 A max.)
- Eight capacitance values in a wide range, related to the noise frequency
- Suitable for narrow pitch insertion
- Suitable for applications requiring thin design
- RoHS compliant

### ■ Recommended Applications

- Digital equipment such as PCs, word processors, printers, HDD, PPC and communication equipment.
- Digital audio and video equipment.
- AC adapters and switching power supplies.
- Electronic musical instruments and other digital equipment.

### ■ Explanation of Part Numbers

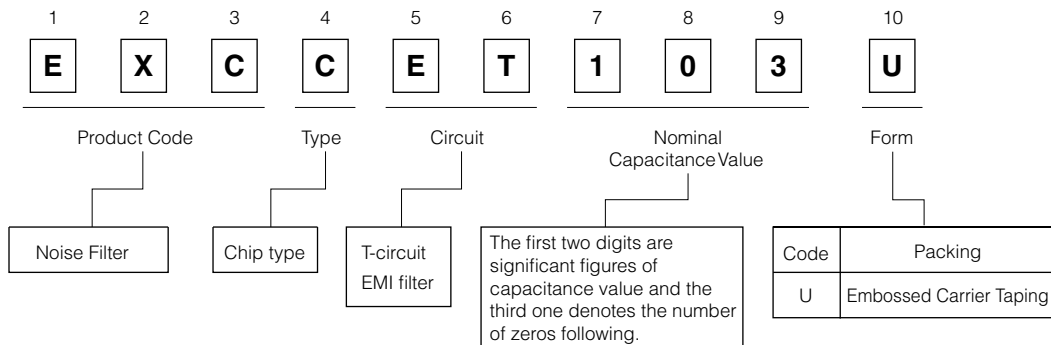

### ■ Construction

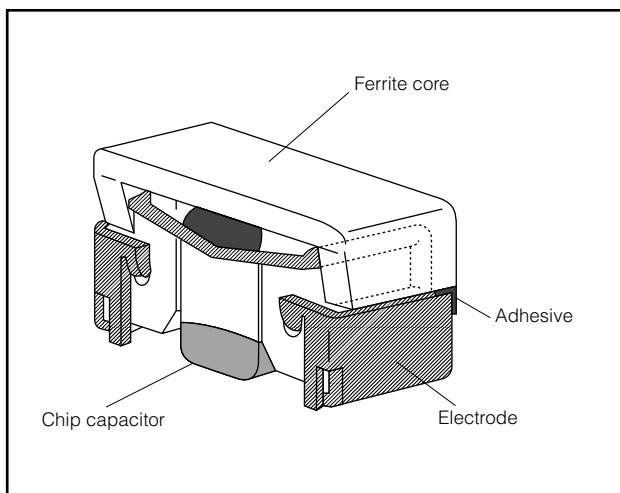

### ■ Dimensions in mm (not to scale)

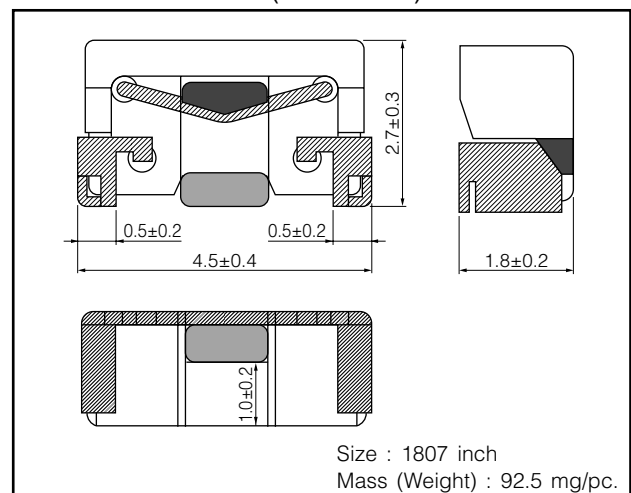

## ■ Ratings

Discontinued

Part Number	Rated Voltage (V DC)	Capacitance <sup>(1)</sup> (pF)	Tolerance (%)	Characteristics <sup>(2)</sup>	Rated Current (A DC)	DC Resistance (mΩ)	25 dB Attenuate Frequency (MHz)	15 dB Attenuate Frequency (MHz)
EXCCE220U	50	22	±20	YB	2	50 max.	800 to 1000	600 to 1000
EXCCE470U	50	47	±20	YB	2	50 max.	450 to 550	350 to 1000
EXCCE101U	50	100	±20	YB	2	50 max.	300 to 450	200 to 900
EXCCE271U	50	270	±20	YB	2	50 max.	200 to 300	80 to 700
EXCCE471U	50	470	±20	YB	2	50 max.	100 to 220	50 to 700
EXCCE102U	50	1000	±20	YB	2	50 max.	65 to 200	30 to 700
EXCCE222U	50	2200	±20	YB	2	50 max.	35 to 180	15 to 700
EXCCE103U	50	10000	±20	YB	2	50 max.	15 to 120	15 to 700

(1) Please inquire to us about the particular capacitance value, on a range of 22 to 10000 pF.  
 (2) Characteristics YB: Maximum capacitance is ±10 % over the temperature range of -25 °C to +85 °C in reference to +20 °C.

- Category Temperature Range -40 °C to +85 °C

## ■ Attenuation Characteristics (Reference Data)

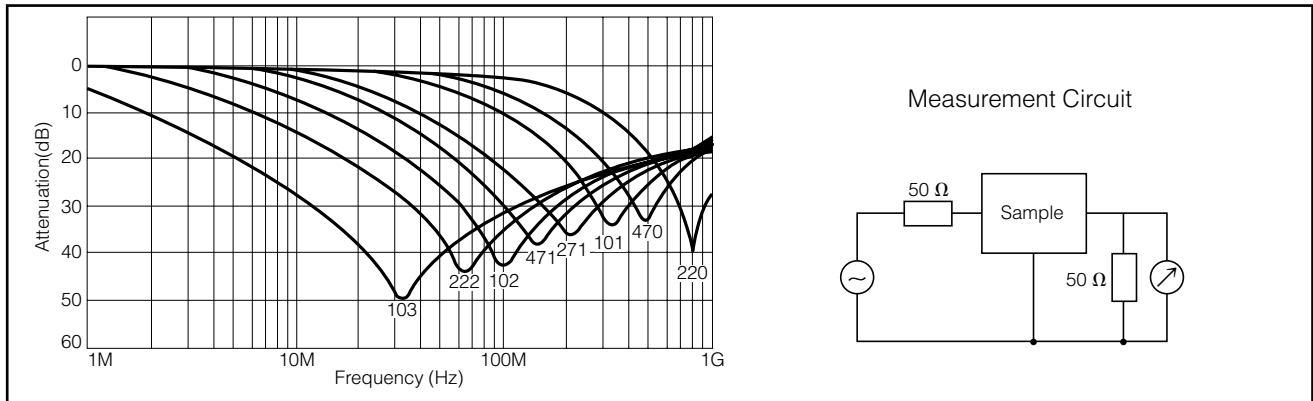

## ■ Packaging Methods (Taping)

- Standard Quantity

Part Number	Kind of Taping	Pitch (P <sub>1</sub> )	Quantity
EXCCE□□□U	Embossed Carrier Taping	4 mm	1000 pcs./reel

### ● Embossed Carrier Taping

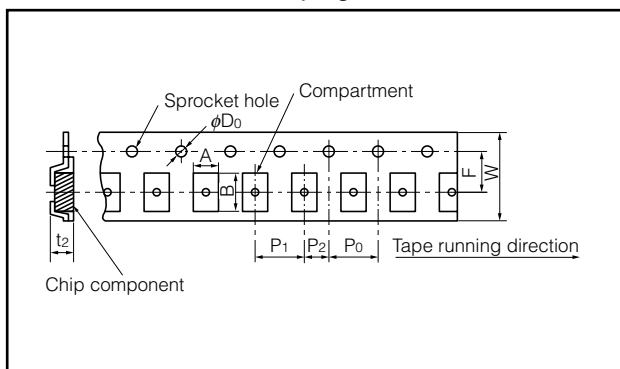

	A	B	W	F	P <sub>1</sub>
Dimensions (mm)	2.2±0.2	4.9±0.2	12.0±0.2	5.50±0.05	4.0±0.1
	P <sub>2</sub>	P <sub>0</sub>	φD <sub>0</sub>	t <sub>2</sub>	
Dimensions (mm)	2.0±0.1	4.0±0.1	1.5±0.1	3.5 max.	

### ● Taping Reel

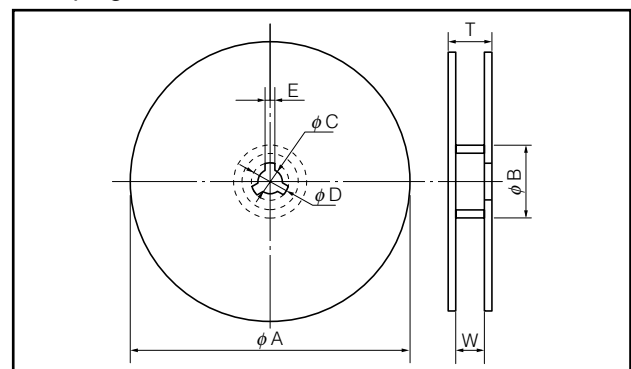

	φA	φB	φC	φD
Dimensions (mm)	180.0 <sup>0</sup> <sub>-3.0</sub>	60.0±1.0	13.0±0.5	21.0±0.8
	E	W	T	
Dimensions (mm)	2.0±0.5	13.0±1.0	16.5 max.	

Design and specifications are each subject to change without notice. Ask factory for the current technical specifications before purchase and/or use. Should a safety concern arise regarding this product, please be sure to contact us immediately.

## Recommended Land Pattern Design(mm) Discontinued

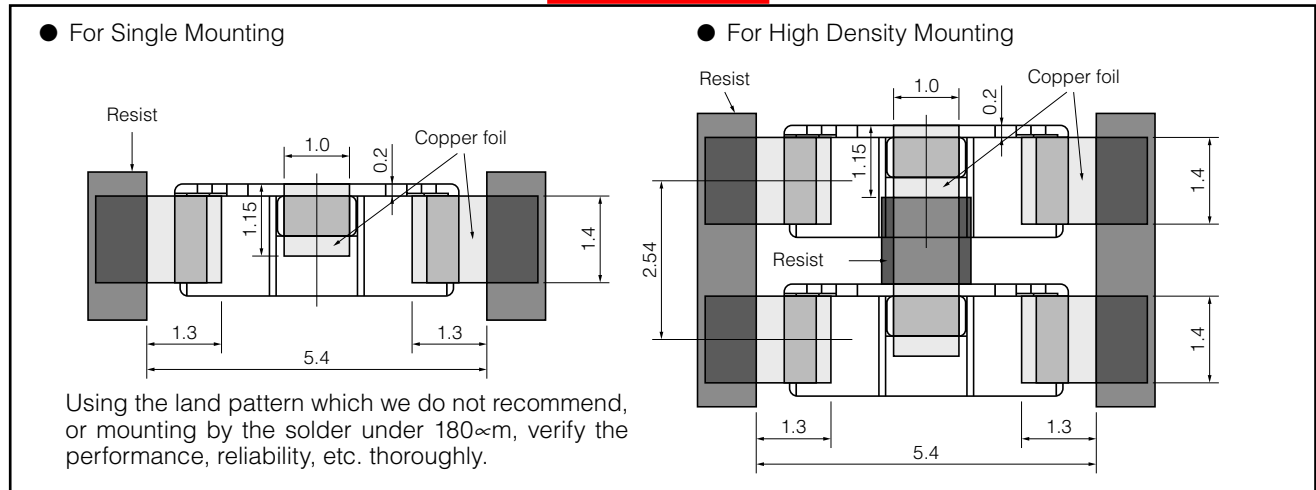

## Recommended Soldering Conditions

Recommendations and precautions are described below.

● Recommended soldering conditions for reflow

- Reflow soldering shall be performed a maximum of two times.
- Please contact us for additional information when used in conditions other than those specified.
- Please measure the temperature of the terminals and study every kind of solder and printed circuit board for solderability before actual use.

● Flow soldering

- Chip EMI Filters cannot be mounted on a printed circuit board by flow soldering. Mount them by reflow soldering.

For soldering (Example : Sn-37Pb)

	Temperature	Time
Preheating	140 °C to 160 °C	60 s to 120 s
Main heating	Above 200 °C	30 s to 40 s
Peak	235 ± 10 °C	max. 10 s

For lead-free soldering (Example : Sn/3Ag/0.5Cu)

	Temperature	Time
Preheating	150 °C to 170 °C	60 s to 120 s
Main heating	Above 230 °C	30 s to 40 s
Peak	max. 260 °C	max. 10 s

<Repair with hand soldering>

- Preheat with a blast of hot air or similar method. Use a soldering iron with a tip temperature of 350 °C or less. Solder each electrode for 3 seconds or less.
- Never touch this product with the tip of a soldering iron.

## ⚠ Safety Precautions

The following are precautions for individual products. Please also refer to the common precautions for Noise Suppression Device shown on this catalog.

1. Use rosin-based flux or halogen-free flux.
2. For cleaning, use an alcohol-based cleaning agent. Before using any other type, consult with our sales person in advance.
3. Do not apply shock to Chip EMI Filters (hereafter called the filters) or pinch them with a hard tool (e.g. pliers and tweezers). Otherwise, their bodies may be chipped, affecting their performance. Excessive mechanical stress may damage the filters. Handle with care.
4. Avoid applying static electricity to the filters.
5. The performance of the filters deteriorates in a circuit that is susceptible to surges or other abnormal voltages. Carefully check the circuit operations before use.
6. Store the filters in a location with a temperature ranging from -5 °C to +40 °C and a relative humidity of 40 % to 60 %, where there are no rapid changes in temperature or humidity.
7. Use the filters within a year after the date of the outgoing inspection indicated on the packages.

单击下面可查看定价，库存，交付和生命周期等信息

[>>Panasonic\(松下\)](#)