

FK4B01110L1

Single N-channel MOS FET

For Load switching circuits

■ Features

- Low Drain-source ON resistance: $R_{DS(on)}$ typ. = $57\text{m}\Omega$ ($V_{GS} = 2.5\text{ V}$)
- CSP (Chip Size Package)
- RoHS compliant (EU RoHS / MSL: Level 1 compliant)

■ Marking Symbol: 1B

■ Packaging

Embossed type (Thermo-compression sealing) : 1 000 pcs / reel (standard)

■ Absolute Maximum Ratings $T_a = 25\text{ }^\circ\text{C}$

Parameter	Symbol	Rating	Unit
Drain-Source Voltage	VDS	12	V
Gate-Source Voltage	VGS	± 8	V
Drain Current	ID1 ^{*1}	2.3	A
	ID2 ^{*2}	3.4	
	ID3 ^{*3}	4.1	
Peak Drain Current	IDp1 ^{*1*4}	18	A
	IDp2 ^{*2*4}	27	
	IDp3 ^{*3*4}	32	
Power Dissipation	PD1 ^{*1}	0.34	W
	PD2 ^{*2}	0.76	
	PD3 ^{*3}	1.1	
Channel Temperature	Tch	150	$^\circ\text{C}$
Operating Ambient Temperature	Topr	-40 ~ +85	$^\circ\text{C}$
Storage Temperature	Tstg	-55 ~ +150	$^\circ\text{C}$

Note *1 FR4 board (25.4mm×25.4mm×1.0mm), Min Cu 36mm² Copper

*2 FR4 board (25.4mm×25.4mm×1.0mm), Full Cu

*3 Ceramic substrate (70mm×70mm×1.0mm)

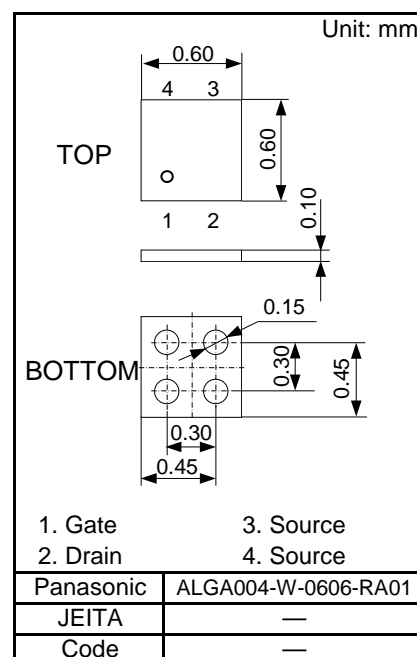
*4 $t = 10\text{ }\mu\text{s}$, Duty Cycle < 1%

■ Internal Connection

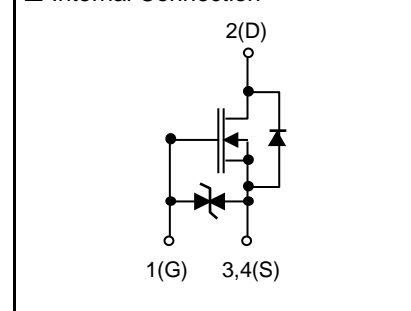

■ Electrical Characteristics Ta = 25 °C ± 3 °C

Parameter	Symbol	Conditions	Min	Typ	Max	Unit
Drain-Source Breakdown Voltage	VDSS	ID = 1 mA, VGS = 0	12			V
Zero Gate Voltage Drain Current	IDSS	VDS = 12 V, VGS = 0			10	μA
Gate-Source Leakage Current	IGSS	VGS = ±8 V, VDS = 0 V			±10	μA
Gate Threshold Voltage	Vth	ID = 118 μA, VDS = 10 V	0.3		1.0	V
Drain-Source ON Resistance	RDS(on)	ID = 1.5 A, VGS = 4.5 V		47	64	mΩ
		ID = 1.0 A, VGS = 2.5 V		57	84	
		ID = 0.5 A, VGS = 1.8 V		70	119	
		ID = 0.25 A, VGS = 1.5 V		91	210	
Input Capacitance ^{*1}	Ciss	VDS = 10 V		274		pF
Output Capacitance ^{*1}	Coss	VGS = 0		63		
Reverse Transfer Capacitance ^{*1}	Crss	f = 1MHz		42		
Turn-on delay time ^{*1,*2}	td(on)	VDD = 6 V VGS = 0 to 4.5 V ID = 1.0 A		3.6		
Rise time ^{*1,*2}	tr			3		
Turn-off delay time ^{*1,*2}	td(off)			34		
Fall time ^{*1,*2}	tf			38		
Total Gate Charge ^{*1}	Qg	VDD = 6 V		2.55		nC
Gate to Source Charge ^{*1}	Qgs	VGS = 4.5 V		0.55		nC
Gate to Drain Miller Charge ^{*1}	Qgd	ID = 1.0 A		0.55		nC
Body Diode Forward Voltage	VF(D-S)	IF = 0.2A, VGS = 0V		0.6	1.2	V

Note Measuring methods are based on JAPANESE INDUSTRIAL STANDARD JIS C 7030 Measuring methods for transistors.

*1 Guaranteed by design, not subject to production testing

*2 Measurement circuit for Turn-on delay time / Rise time / Turn-off delay time / Fall time

■ Electrical State Discharge Characteristics

Standard	Test Type	Symbol	Conditions	Class	Value	Unit
AEC-Q101-001	Human body model	HBM	C = 100 pF, R = 1.5 kΩ	H1B	>500 to ≤ 1k	V
	Machine model	MM	C = 200 pF, R = 0 Ω	M1B	>50 to ≤ 100	V

Note2: Measurement circuit

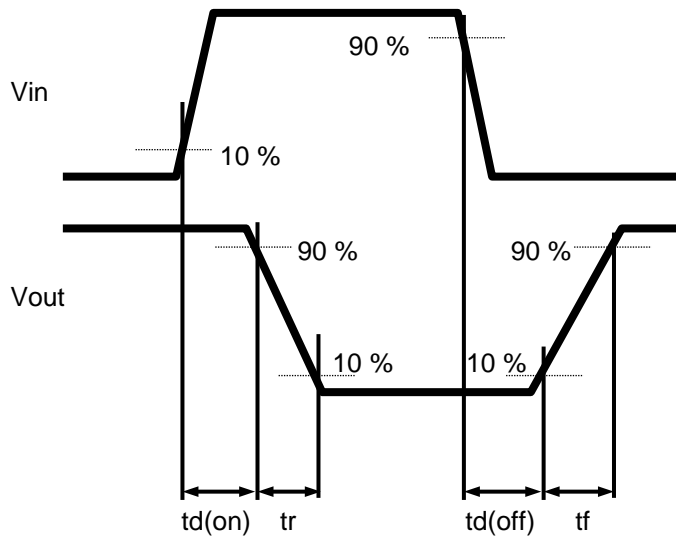
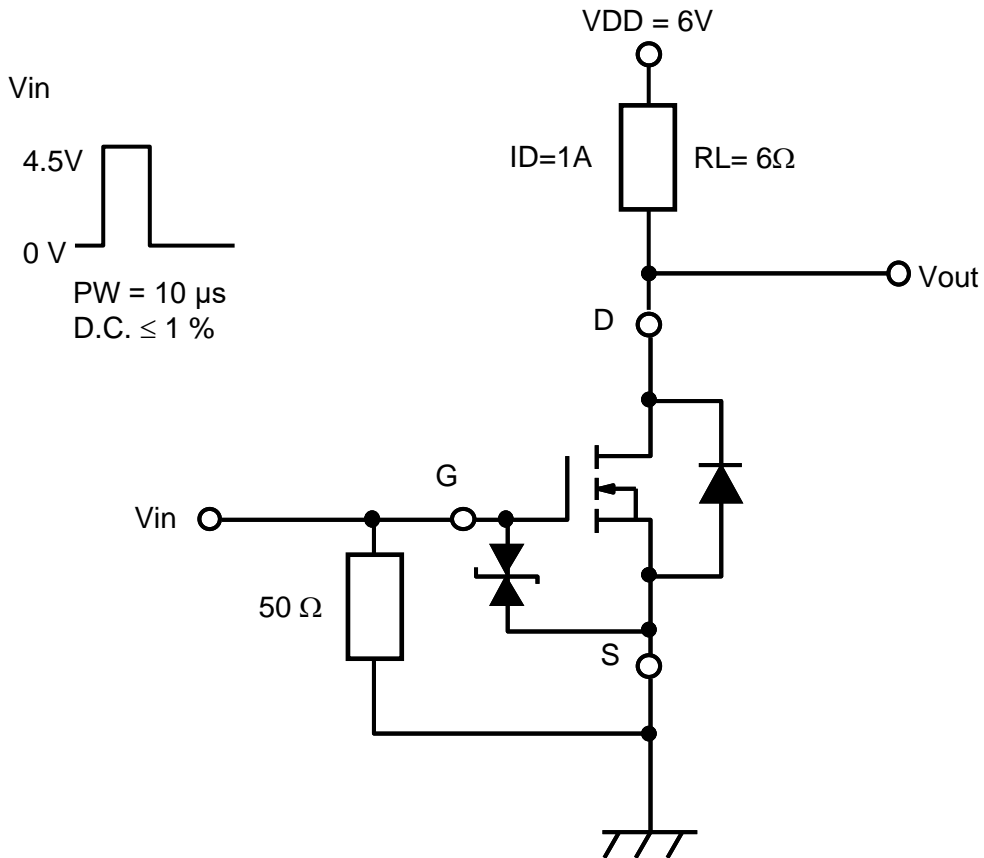



ID - VDS

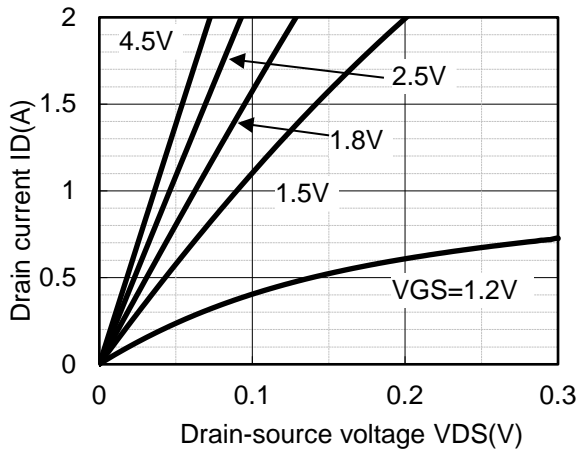

RDS(on) - ID

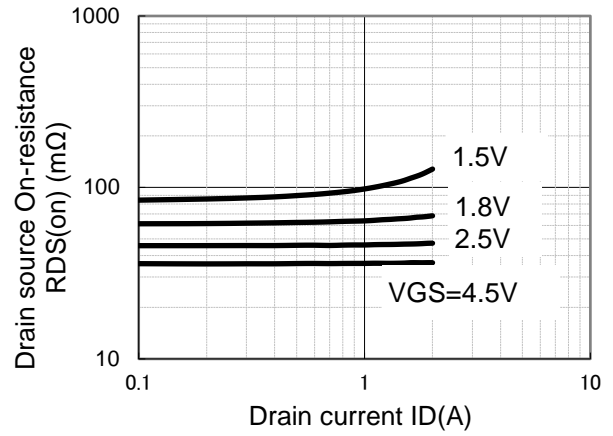

ID - VGS

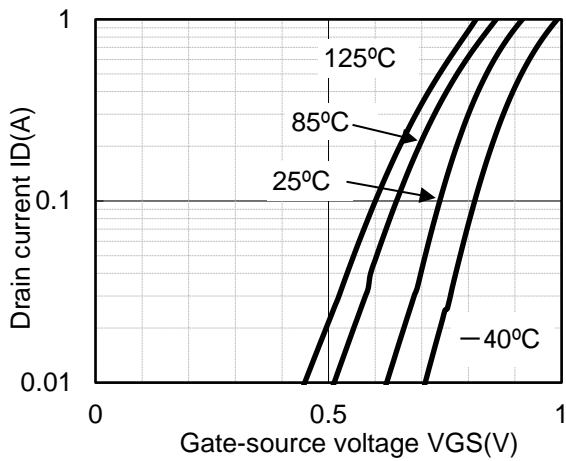

RDS(on) - VGS

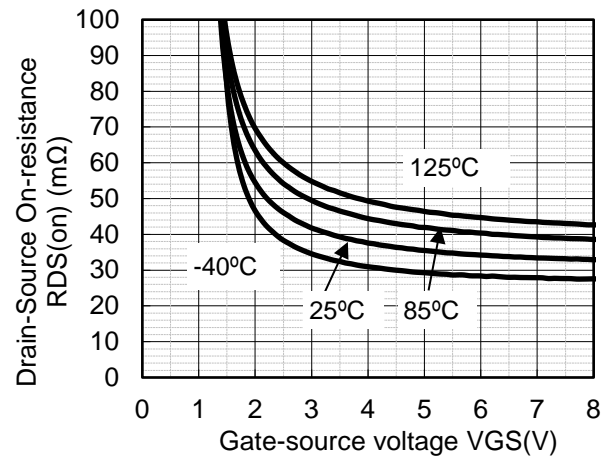

IF - VF

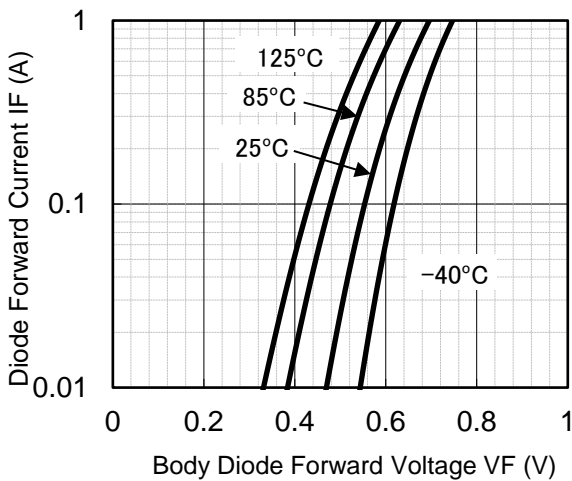

IGS - VGS

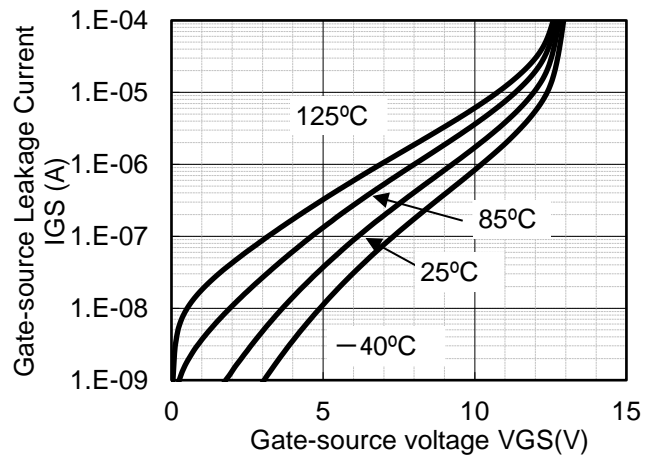



IDS - VDS

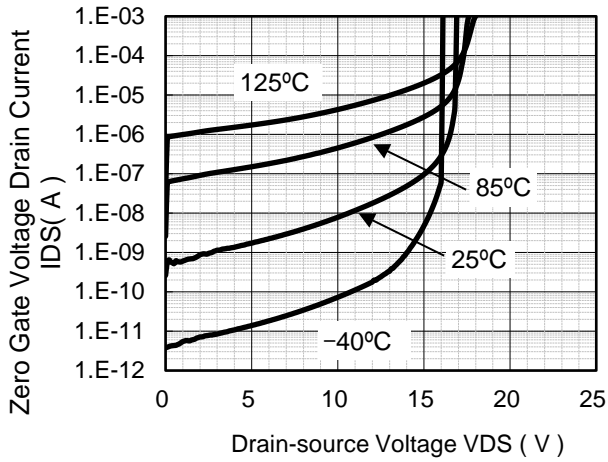

Dynamic Input/Output Characteristics

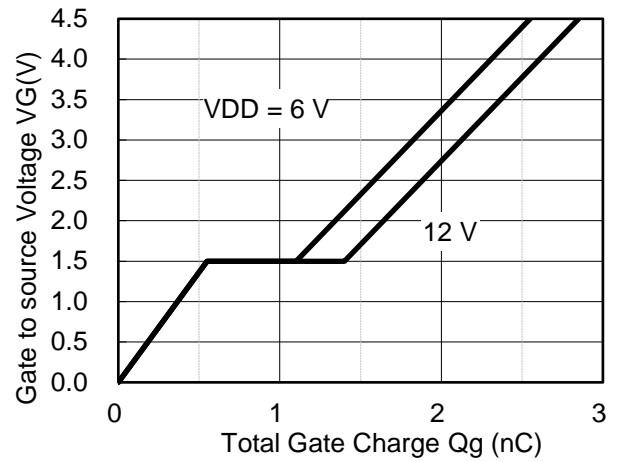

Rth - tsw

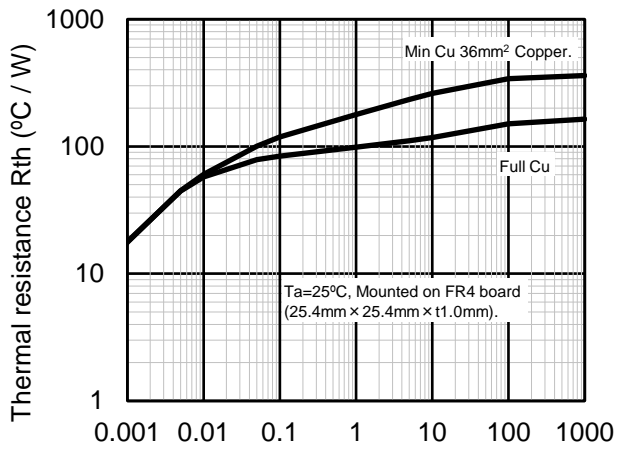

Safe Operating Area

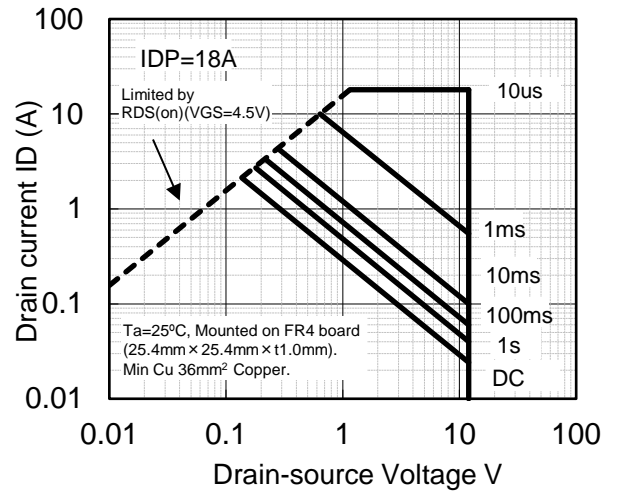

Pulse Width tsw (s)

■ ALGA004-W-0606-RA01

Unit: mm

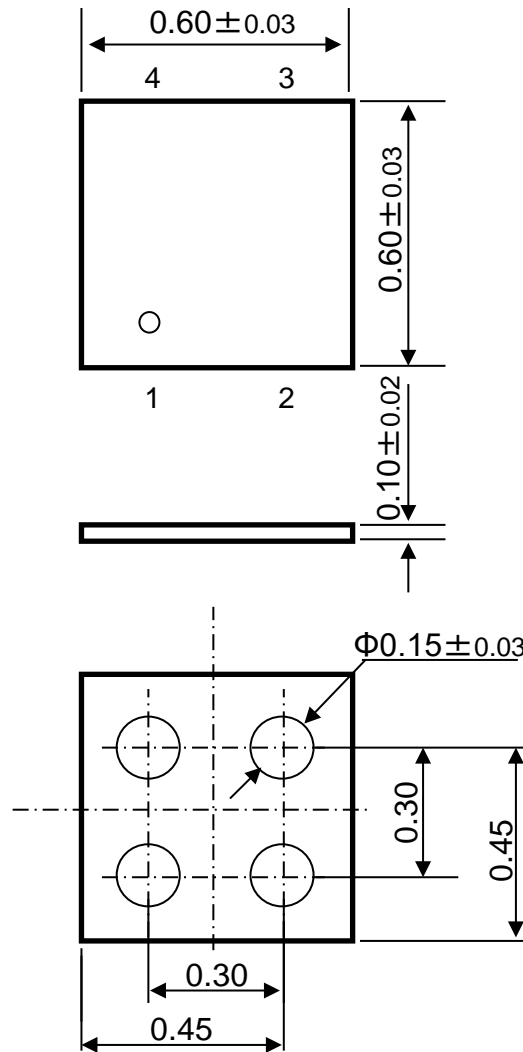

■ Land Pattern (Reference)

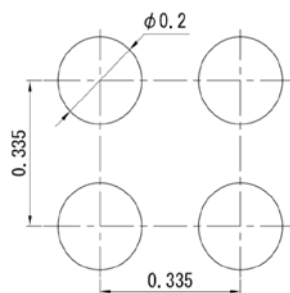

单击下面可查看定价，库存，交付和生命周期等信息

[>>Panasonic\(松下\)](#)