

# HG-C SERIES

Related Information

- General terms and conditions..... F-3
- Selection guide ..... P.169~
- Glossary of terms / General precautions P.1549~ / P.1552~
- About laser beam..... P.1593~

- FIBER SENSORS
- LASER SENSORS
- PHOTOELECTRIC SENSORS
- MICRO PHOTOELECTRIC SENSORS
- AREA SENSORS
- SAFETY LIGHT CURTAINS / SAFETY COMPONENTS
- PRESSURE / FLOW SENSORS
- INDUCTIVE PROXIMITY SENSORS
- PARTICULAR USE SENSORS
- SENSOR OPTIONS
- SIMPLE WIRE-SAVING UNITS
- WIRE-SAVING SYSTEMS
- MEASUREMENT SENSORS
- STATIC CONTROL DEVICES
- LASER MARKERS
- PLC
- HUMAN MACHINE INTERFACES
- ENERGY MANAGEMENT SOLUTIONS
- FA COMPONENTS
- MACHINE VISION SYSTEMS
- UV CURING SYSTEMS

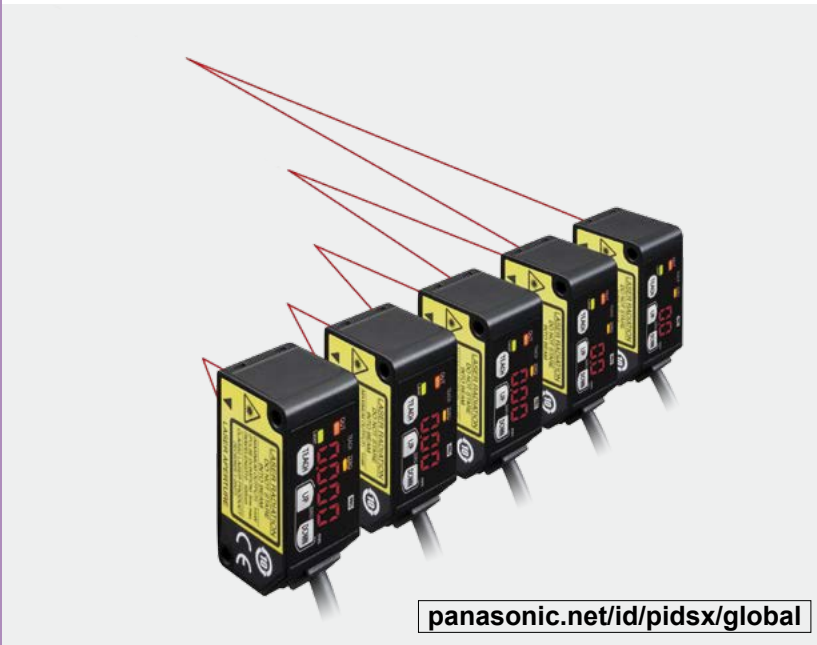

This product is classified as a Class 2 Laser Product under IEC / JIS / GB standards and FDA regulations. Do not look at the laser beam directly or through an optical system such as a lens.

\* This product complies with 21 CFR 1040.10 and 1040.11 Laser Notice No. 50, dated June 24, 2007, issued by CDRH (Center for Devices and Radiological Health) under the FDA (Food and Drug Administration).

Test input  
 PNP output type available  
 Timer

## Reliable detection in repeatability 10 μm 0.394 mil

### Overwhelmingly stable

### Fitted with a precise CMOS image sensor and an original algorithm

Thanks to a precise CMOS image sensor, it is now possible to perform highly precise measurements in the order of 1/100 mm 0.0003 in. The existing adjustable range reflective sensors cannot achieve such accuracy.

**Repeatability 10 μm (0.394 mil)**  
**[HG-C1030(-P)]**

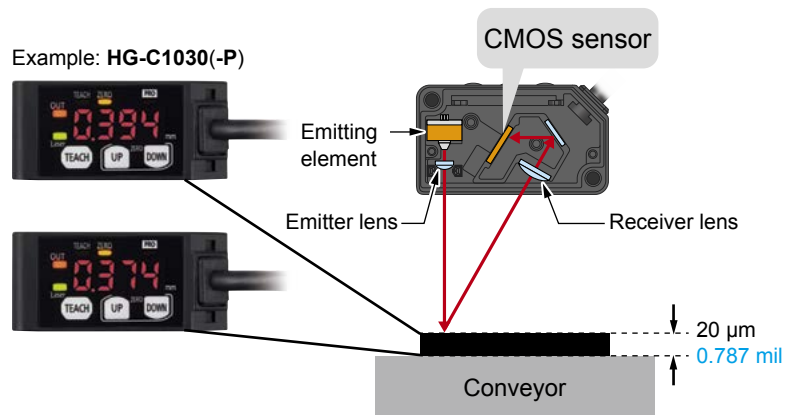

- Selection Guide
- Amplifier Built-in
- Amplifier-separated

EX-L200

HG-C

**APPLICATIONS**

- FIBER SENSORS
- LASER SENSORS
- PHOTOELECTRIC SENSORS
- MICRO PHOTOELECTRIC SENSORS
- AREA SENSORS
- SAFETY LIGHT CURTAINS / SAFETY COMPONENTS
- PRESSURE / FLOW SENSORS
- INDUCTIVE PROXIMITY SENSORS
- PARTICULAR USE SENSORS
- SENSOR OPTIONS
- SIMPLE WIRE-SAVING UNITS
- WIRE-SAVING SYSTEMS
- MEASUREMENT SENSORS
- STATIC CONTROL DEVICES
- LASER MARKERS
- PLC
- HUMAN MACHINE INTERFACES
- ENERGY MANAGEMENT SOLUTIONS
- FA COMPONENTS
- MACHINE VISION SYSTEMS
- UV CURING SYSTEMS

- Selection Guide
- Amplifier Built-in
- Amplifier-separated
- EX-L200**
- HG-C**

**Detecting warpage of a circuit board**

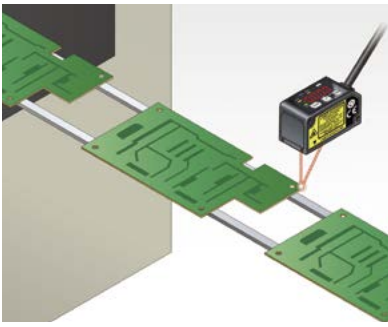

**Checking for overlapped lead frames**

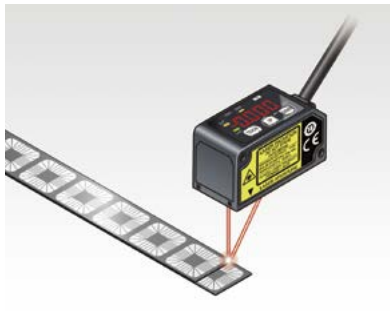

**Judging front or back of cover of electric parts**

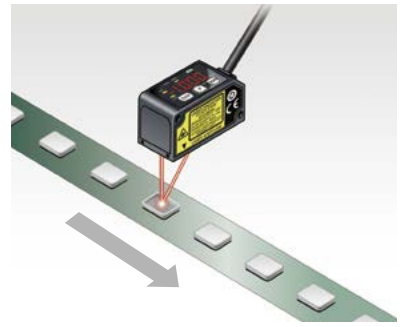

**Checking for presence of packing**

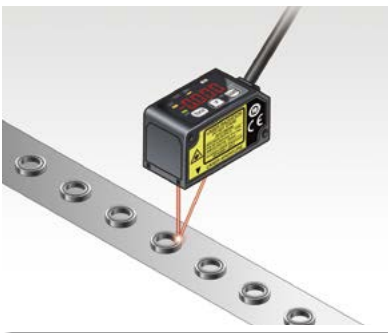

**Checking for presence of O ring**



**Detecting a seam (overlap) of functional sheet**

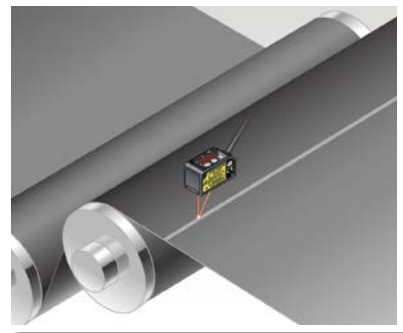

**Compact and light-weight**

The **HG-C** series is the smallest CMOS laser sensor in industry \*. W20 × H44 × D25 mm **W0.787 × H1.732 × D0.984 in**, 35 g approx. (without cable)

\* As of May 2015, in-company survey.

**A new optical system with a built-in mirror**

In general, more accurate and stable measurements can be obtained by increasing the optical path length between the light-receiving part and the light receiving element (CMOS), but this also increases the sensor depth and the sensor body gets bigger.

The **HG-C** series sensors incorporating a new optical system with a built-in mirror provides smaller sensor depth as well as higher measurement accuracy equivalent to displacement sensors.

**Controlling the dispenser head height**

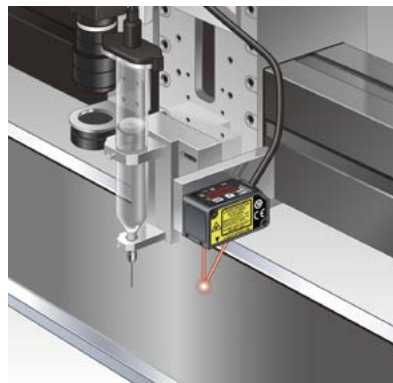

**Controlling the moulder head height**

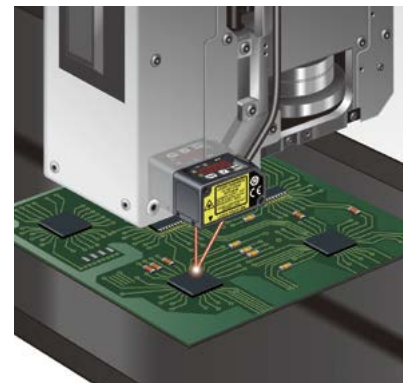

**Controlling the parallel link robot height**

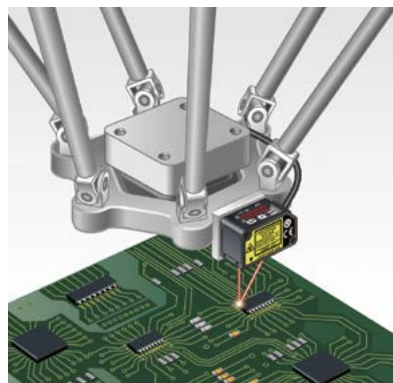

**Installable on a food packaging line where water splashes (IP67)**



Remove water droplets on detection surface to achieve correct measurement.

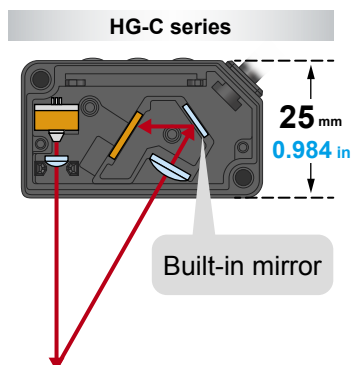

- FIBER SENSORS
- LASER SENSORS**
- PHOTOELECTRIC SENSORS
- MICRO PHOTOELECTRIC SENSORS
- AREA SENSORS
- SAFETY LIGHT CURTAINS / SAFETY COMPONENTS
- PRESSURE / FLOW SENSORS
- INDUCTIVE PROXIMITY SENSORS
- PARTICULAR USE SENSORS
- SENSOR OPTIONS
- SIMPLE WIRE-SAVING UNITS
- WIRE-SAVING SYSTEMS
- MEASUREMENT SENSORS
- STATIC CONTROL DEVICES
- LASER MARKERS
- PLC
- HUMAN MACHINE INTERFACES
- ENERGY MANAGEMENT SOLUTIONS
- FA COMPONENTS
- MACHINE VISION SYSTEMS
- UV CURING SYSTEMS

### An aluminum die-cast enclosure protects from strain and heat

A light-weight but strong die-cast aluminum enclosure has been adopted. A compact, solid body enclosure reduces the impact of strain and heat on the measurement accuracy.

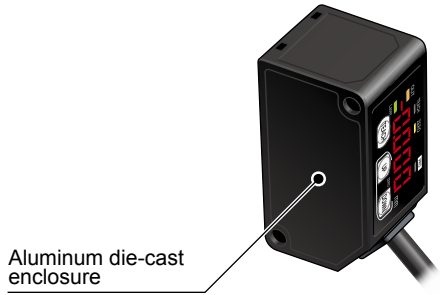

### Long distance measurement

Measurement center 400 mm **15.748 in** type **HG-C1400(-P)** and 200 mm **7.874 in** type **HG-C1200(-P)** are available.

**Detecting on-vehicle seats**



**Judging front or back of cover of cast parts**

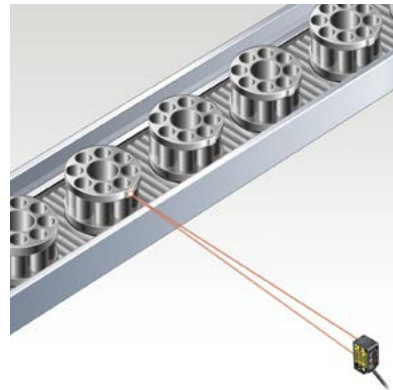

**Measurement of a remaining functional sheet**

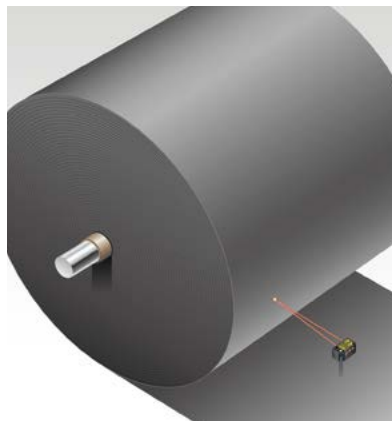

**Detecting parts through a viewing port**

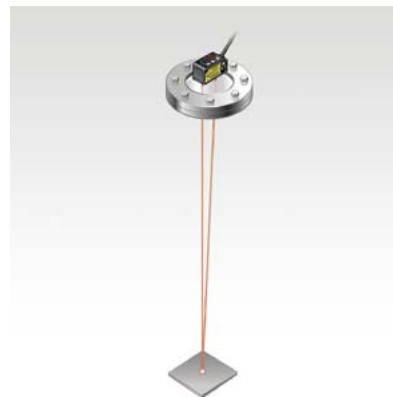

- Selection Guide
- Amplifier Built-in
- Amplifier-separated
- EX-L200**
- HG-C**

Equipped with 0 to +5 V analog output and 4 to 20 mA analog current output

The value can be measured with a distance measurement sensor.

- Linearity:  $\pm 0.1\%$  F.S.\*
- Temperature characteristics:  $0.03\%$  F.S./ $^{\circ}\text{C}$

\*HG-C1030(-P) / HG-C1050(-P) / HG-C1100(-P)

The sensor not only indicates measured values in mm but also produces analog outputs. Various calculations and storage (logging) can be performed when output is taken into a PLC + analog unit.

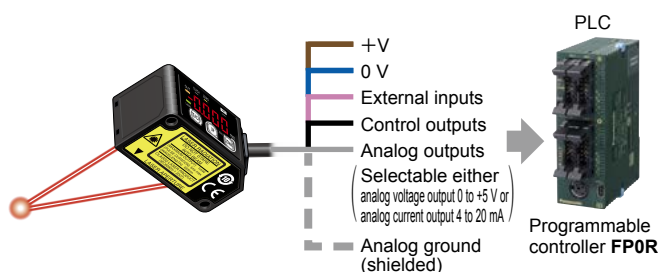

- FP0R-C10 control unit (with RS232C port) AFP0RC10CRS
- A/D converter unit with input channels (terminal block type) AFP0RAD8

■ Linearity characteristics [Typical example: HG-C1030(-P)]

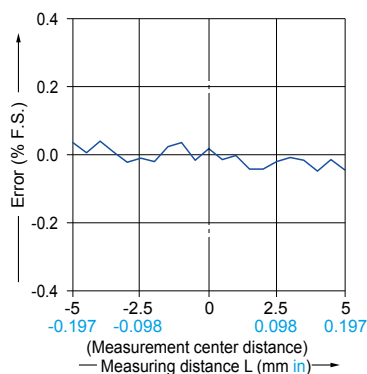

Measuring the hoop slack

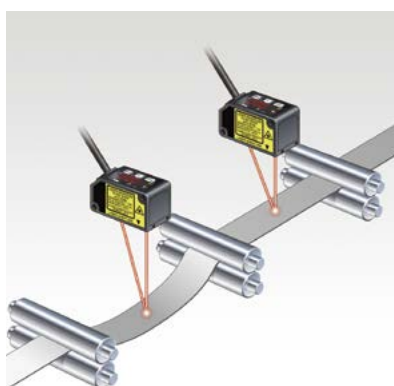

Measuring the insertion depth of an actuator

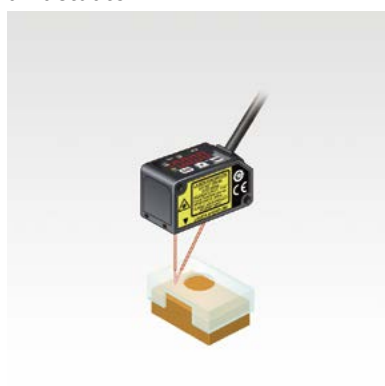

Measuring the thickness of a panel

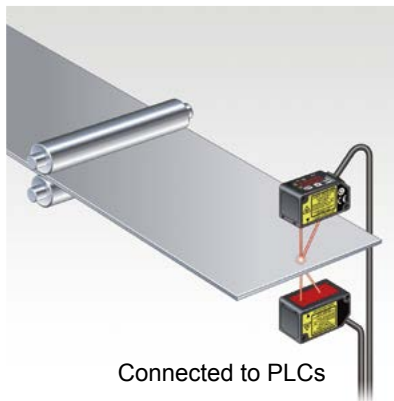

Measuring the thickness of a part

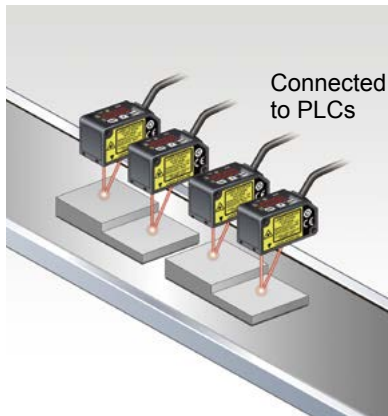

FIBER SENSORS

LASER SENSORS

PHOTOELECTRIC SENSORS

MICRO PHOTOELECTRIC SENSORS

AREA SENSORS

SAFETY LIGHT CURTAINS / SAFETY COMPONENTS

PRESSURE / FLOW SENSORS

INDUCTIVE PROXIMITY SENSORS

PARTICULAR USE SENSORS

SENSOR OPTIONS

SIMPLE WIRE-SAVING UNITS

WIRE-SAVING SYSTEMS

MEASUREMENT SENSORS

STATIC CONTROL DEVICES

LASER MARKERS

PLC

HUMAN MACHINE INTERFACES

ENERGY MANAGEMENT SOLUTIONS

FA COMPONENTS

MACHINE VISION SYSTEMS

UV CURING SYSTEMS

Selection Guide

Amplifier Built-in

Amplifier-separated

EX-L200

HG-C

- FIBER SENSORS
- LASER SENSORS
- PHOTOELECTRIC SENSORS
- MICRO PHOTOELECTRIC SENSORS
- AREA SENSORS
- SAFETY LIGHT CURTAINS / SAFETY COMPONENTS
- PRESSURE / FLOW SENSORS
- INDUCTIVE PROXIMITY SENSORS
- PARTICULAR USE SENSORS
- SENSOR OPTIONS
- SIMPLE WIRE-SAVING UNITS
- WIRE-SAVING SYSTEMS
- MEASUREMENT SENSORS
- STATIC CONTROL DEVICES
- LASER MARKERS
- PLC
- HUMAN MACHINE INTERFACES
- ENERGY MANAGEMENT SOLUTIONS
- FA COMPONENTS
- MACHINE VISION SYSTEMS
- UV CURING SYSTEMS
- Selection Guide
- Amplifier Built-in
- Amplifier-separated
- EX-L200
- HG-C

## Useful functions

### Teaching & window comparator mode

With an object below the sensor, press the TEACH key to set the valid range for distances via threshold values. There are 3 methods for setting the valid range: 1-point, 2-point, and 3-point teaching.

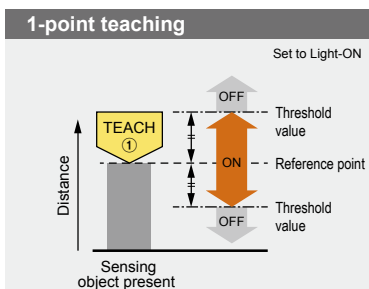

Perform 1-point teaching and the threshold range is set for the distance from the reference surface of the sensing object.

This is used for sensing within the threshold range.

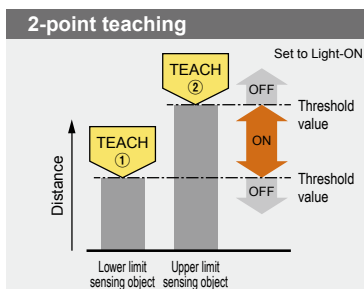

Press TEACH once for the lower (first point) and once for the upper limit (second point).

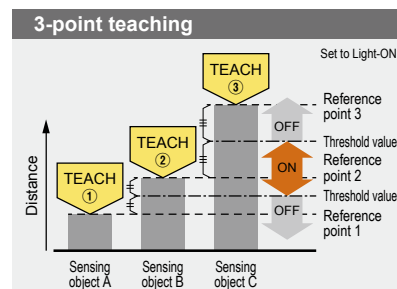

This is the method to set the threshold range by conducting the teaching at 3 points (sensing object A, B and C). After teaching, the reference points are automatically sorted in ascending order (reference point 1, 2 and 3). The thresholds are set at the midpoints between reference point 1 and 2, and 2 and 3, respectively.



In addition to the teaching & window comparator mode, the **“rising differential mode”**, **“trailing differential mode”** and **“normal sensing mode”** are available. In normal sensing mode, **“2-point teaching”** as basic teaching and **“limit teaching”**, which is useful for very small objects and backgrounds, are possible.

### Timer setting function

The time mode options are “OFF-delay timer,” “ON-delay timer,” “One-shot timer” and “no timer.” The counting time is fixed to 5 ms.

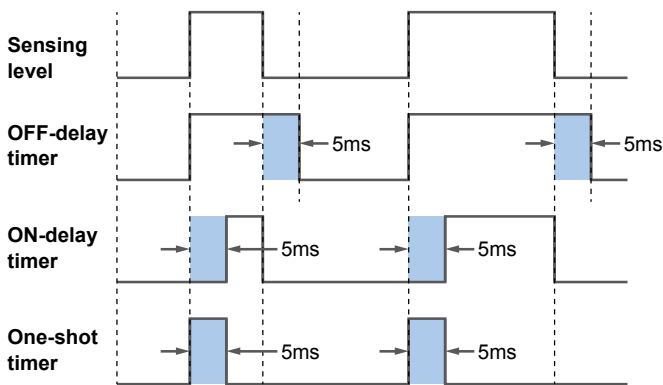

Timer period: 5 ms (fixed)

#### OFF-delay timer

Function: Extends output signals by 5 ms.  
Usage: Appropriate in case a connected device is slow to respond and ON time is required to extend.

#### ON-delay timer

Function: Overrides output signals for 5 ms after detection.  
Usage: Convenient way to override temporary signals and control with a time lag.

#### One-shot timer

Function: Sends output signals for only 5 ms after detection.  
Usage: Useful when the signal duration needs to be constant to meet inputs from a connected device. This mode is also used to extend temporary signals by a desired length of time.

### Zero set function

This function compulsorily sets the measured value to "zero." The zero point can be set at a desired value. It is useful when measuring steps or tolerance with reference to the height of a sensing object.

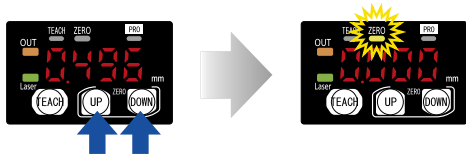

Keep pressing both keys for 3 seconds.

- \* The zero set indicator (yellow) will turn ON while the zero set is valid.
- \* When the zero set function is executed while the peak hold function or the bottom hold function is valid, the held measurement value is reset.
- \* When the display setting is set to offset, the zero set function cannot be set.

### External input setting function

One of four functions, "zero setting function," "teaching function," "emission stopping function" and "trigger function" can be assigned to an external input line.

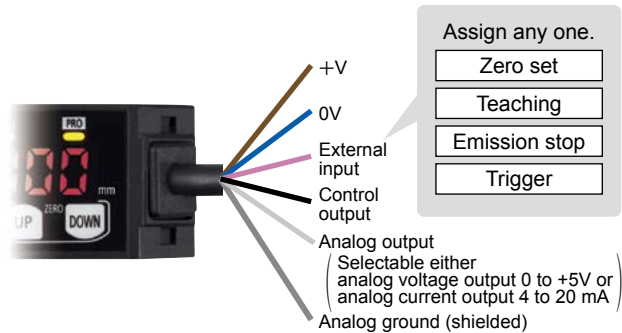

### Display setting function

How to indicate measured values of the moving sensed object can be chosen from three options, "Normal," "Invert" and "Offset."

Example: HG-C1050(-P)

|                 |        | Outside the measuring range | Measuring near point | Measurement center | Measuring far point | Outside the measuring range |
|-----------------|--------|-----------------------------|----------------------|--------------------|---------------------|-----------------------------|
| Display setting | Normal | ---                         | 1500 mm              | 000 mm             | -1500 mm            | ---                         |
|                 | Invert | ---                         | -1500 mm             | 000 mm             | 1500 mm             | ---                         |
|                 | Offset | ---                         | 3000 mm              | 1500 mm            | 000 mm              | ---                         |

■ Relation between the setting display and the analog output (In case of analog voltage output)

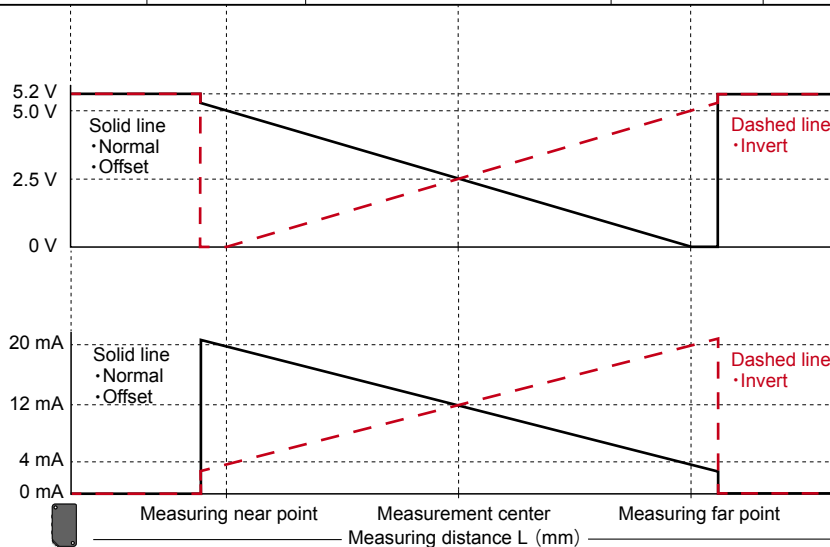

### Peak and bottom hold functions

The peak hold function holds the maximum measured value which is output and displayed. The bottom hold function holds the minimum measured value which is output and displayed.

- \* The peak hold function and the bottom hold function cannot be set at the same time.
- \* When the zero set function is executed while the peak hold function or the bottom hold function is valid, the held measurement value is reset.

### Threshold value fine adjustment function

Fine adjustment of threshold values can be performed while measurement is proceeding on the display, and even after teaching.

### Key lock function

This function protects setting conditions from unintentional changes.

\* For other functions and procedures for setting the functions, see "PRO Mode Setting" from p.196~.

FIBER SENSORS

LASER SENSORS

PHOTOELECTRIC SENSORS

MICRO PHOTOELECTRIC SENSORS

AREA SENSORS

SAFETY LIGHT CURTAINS / SAFETY COMPONENTS

PRESSURE / FLOW SENSORS

INDUCTIVE PROXIMITY SENSORS

PARTICULAR USE SENSORS

SENSOR OPTIONS

SIMPLE WIRE-SAVING UNITS

WIRE-SAVING SYSTEMS

MEASUREMENT SENSORS

STATIC CONTROL DEVICES

LASER MARKERS

PLC

HUMAN MACHINE INTERFACES

ENERGY MANAGEMENT SOLUTIONS

FA COMPONENTS

MACHINE VISION SYSTEMS

UV CURING SYSTEMS

Selection Guide

Amplifier Built-in

Amplifier-separated

EX-L200

HG-C

FIBER SENSORS

LASER SENSORS

PHOTO-ELECTRIC SENSORS

MICRO PHOTO-ELECTRIC SENSORS

AREA SENSORS

SAFETY LIGHT CURTAINS / SAFETY COMPONENTS

PRESSURE / FLOW SENSORS

INDUCTIVE PROXIMITY SENSORS

PARTICULAR USE SENSORS

SENSOR OPTIONS

SIMPLE WIRE-SAVING UNITS

WIRE-SAVING SYSTEMS

MEASURE-MENT SENSORS

STATIC CONTROL DEVICES

LASER MARKERS

PLC

HUMAN MACHINE INTERFACES

ENERGY MANAGEMENT SOLUTIONS

FA COMPONENTS

MACHINE VISION SYSTEMS

UV CURING SYSTEMS

Selection Guide

Amplifier Built-in

Amplifier-separated

EX-L200

HG-C

## ORDER GUIDE

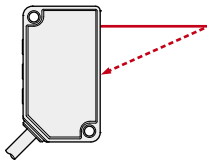
| Type                                       | Appearance  | Measurement center distance and measurement range | Repeatability   | Beam diameter (Note)       | Model No.  |            |
|--|---|---|---|----------------------------|------------|------------|
|  |   |   |   |                            | NPN output | PNP output |
| Measurement center 30mm<br>1.181 in type   |  | 30 ± 5 mm<br>1.181 ± 0.197 in                     | 10 μm<br>0.394 mil  | ø50 μm 1.969 mil approx.   | HG-C1030   | HG-C1030-P |
| Measurement center 50mm<br>1.969 in type   |   | 50 ± 15 mm<br>1.969 ± 0.591 in                    | 30 μm<br>1.181 mil  | ø70 μm 2.756 mil approx.   | HG-C1050   | HG-C1050-P |
| Measurement center 100mm<br>3.937 in type  |   | 100 ± 35 mm<br>3.937 ± 1.328 in                   | 70 μm<br>2.756 mil  | ø120 μm 4.724 mil approx.  | HG-C1100   | HG-C1100-P |
| Measurement center 200mm<br>7.874 in type  |   | 200 ± 80 mm<br>7.874 ± 3.150 in                   | 200 μm<br>7.874 mil   | ø300 μm 11.811 mil approx. | HG-C1200   | HG-C1200-P |
| Measurement center 400mm<br>15.748 in type |   | 400 ± 200 mm<br>15.748 ± 7.874 in                 | 300 μm 11.811 mil<br>(Measuring distance 200 to 400 mm 7.874 to 15.748 in)<br>800 μm 31.496 mil<br>(Measuring distance 400 to 600 mm 15.748 to 23.622 in) | ø500 μm 19.685 mil approx. | HG-C1400   | HG-C1400-P |

Note: This is the size in the measurement center distance. These values were defined by using 1/e<sup>2</sup> (13.5% approx.) of the center light intensity. Due to leak light outside the specified area, the reflectance around the detecting point may be higher than at the point and this may affect the measurement value.

## OPTIONS

| Designation                    | Model No.       | Description                  |
|--------------------------------|-----------------|------------------------------|
| Simple mounting bracket (Note) | <b>MS-HG-01</b> | Foot angled mounting bracket |

Note: Due to the simple mounting bracket, the sensing characteristics may not be hold depending on the installation condition, in case of the purposes for acquiring the displacement data and a fine detecting.

### Simple mounting bracket

• **MS-HG-01**

Material: Stainless steel (SUS304)

Two M3 (length 25 mm 0.984 in) screws with washers (SPCC) are attached.

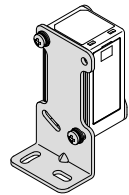

## SPECIFICATIONS

| Item                            | Model No. | Type       | Measurement center<br>30mm type   | Measurement center<br>50mm type    | Measurement center<br>100mm type  | Measurement center<br>200mm type  | Measurement center<br>400mm type  |
|---------------------------------|-----------|------------|---|------------------------------------|---|---|---|
|                                 |           | NPN output | <b>HG-C1030</b>   | <b>HG-C1050</b>                    | <b>HG-C1100</b>   | <b>HG-C1200</b>   | <b>HG-C1400</b>   |
|                                 |           | PNP output | <b>HG-C1030-P</b>   | <b>HG-C1050-P</b>                  | <b>HG-C1100-P</b>   | <b>HG-C1200-P</b>   | <b>HG-C1400-P</b>   |
| CE marking directive compliance |           |            | EMC Directive, RoHS Directive   |                                    |   |   |   |
| Measurement center distance     |           |            | 30 mm <b>1.181 in</b>   | 50 mm <b>1.969 in</b>              | 100 mm <b>3.937 in</b>  | 200 mm <b>7.874 in</b>  | 400 mm <b>15.748 in</b>   |
| Measurement range               |           |            | ±5 mm <b>0.197 in</b>   | ±15 mm <b>0.591 in</b>             | ±35 mm <b>1.328 in</b>  | ±80 mm <b>3.150 in</b>  | ±200 mm <b>7.874 in</b>   |
| Repeatability                   |           |            | 10 μm <b>0.394 mil</b>  | 30 μm <b>1.181 mil</b>             | 70 μm <b>2.756 mil</b>  | 200 μm <b>7.874 mil</b>   | 300 μm <b>11.811 mil</b><br>(Measuring distance 200 to 400 mm <b>7.874 to 15.748 in</b> )<br>800 μm <b>31.496 mil</b><br>(Measuring distance 400 to 600 mm <b>15.748 to 23.622 in</b> ) |
| Linearity                       |           |            | ±0.1 % F.S.   |                                    |   | ±0.2 % F.S.<br>(Measuring distance 200 to 400 mm <b>7.874 to 15.748 in</b> )<br>±0.3 % F.S.<br>(Measuring distance 400 to 600 mm <b>15.748 to 23.622 in</b> ) |   |
| Temperature characteristic      |           |            | 0.03 % F.S./°C  |                                    |   |   |   |
| Light source                    |           |            | Red semiconductor laser Class 2 [IEC / JIS / GB / FDA (Note 2)] Max. output: 1 mW, emission peak wavelength: 655 nm <b>0.026 mil</b>  |                                    |   |   |   |
| Beam diameter (Note 3)          |           |            | ø50 μm <b>1.969 mil</b><br>approx.  | ø70 μm <b>2.756 mil</b><br>approx. | ø120 μm <b>4.724 mil</b><br>approx.   | ø300 μm <b>11.811 mil</b><br>approx.  | ø500 μm <b>19.685 mil</b><br>approx.  |
| Supply voltage                  |           |            | 12 to 24 V DC ±10 %, Ripple P-P 10 % or less  |                                    |   |   |   |
| Power consumption               |           |            | 40 mA or less (at 24 V DC supply voltage), 65 mA or less (at 12 V DC supply voltage)  |                                    |   |   |   |
| Control output                  |           |            | <NPN output type><br>NPN open-collector transistor <ul style="list-style-type: none"> <li>• Maximum sink current: 50 mA</li> <li>• Applied voltage: 30 V DC or less (Between control output to 0V)</li> <li>• Residual voltage: 1.5 V or less (at 50 mA sink current)</li> <li>• Leakage current: 0.1 mA or less</li> </ul> |                                    | <PNP output type><br>PNP open-collector transistor <ul style="list-style-type: none"> <li>• Maximum source current: 50 mA</li> <li>• Applied voltage: 30 V DC or less (Between control output to +V)</li> <li>• Residual voltage: 1.5 V or less (at 50 mA source current)</li> <li>• Leakage current: 0.1 mA or less</li> </ul> |   |   |
| Output operation                |           |            | Switchable between either Light-ON or Dark-ON   |                                    |   |   |   |
| Short-circuit protection        |           |            | Incorporated (auto reset type)  |                                    |   |   |   |
| Analog output                   |           |            | Analog voltage output <ul style="list-style-type: none"> <li>• Output range: 0 to +5 V (at alarm: +5.2 V)</li> <li>• Output impedance: 100 Ω</li> </ul>   |                                    | Analog current output <ul style="list-style-type: none"> <li>• Output range: 4 to 20 mA (at alarm: 0 mA)</li> <li>• Load impedance: 300 Ω or less</li> </ul>  |   |   |
| Response time                   |           |            | Switchable between 1.5 ms / 5 ms / 10 ms  |                                    |   |   |   |
| External input                  |           |            | <NPN output type><br>NPN non-contact input <ul style="list-style-type: none"> <li>• Input conditions</li> <li>Invalid: +8 V to +V DC or Open</li> <li>Valid: 0 to +1.2 V DC</li> <li>• Input impedance: 10 kΩ approx.</li> </ul>  |                                    | <PNP output type><br>PNP non-contact input <ul style="list-style-type: none"> <li>• Input conditions</li> <li>Invalid: 0 to +0.6 V DC or Open</li> <li>Valid: +4 V to +V DC</li> <li>• Input impedance: 10 kΩ approx.</li> </ul>  |   |   |
| Pollution degree                |           |            | 2   |                                    |   |   |   |
| Ambient altitude                |           |            | 2,000 m <b>6561.680 ft</b> or less  |                                    |   |   |   |
| Protection                      |           |            | IP67 (IEC)  |                                    |   |   |   |
| Ambient temperature             |           |            | -10 to +45 °C <b>-14 to 113 °F</b> (No dew condensation or icing allowed), Storage: -20 to +60 °C <b>-4 to 140 °F</b>   |                                    |   |   |   |
| Ambient humidity                |           |            | 35 to 85 % RH, Storage: 35 to 85 % RH   |                                    |   |   |   |
| Ambient illuminance             |           |            | Incandescent light: 3,000 lx or less at the light-receiving face  |                                    |   |   |   |
| Vibration resistance            |           |            | 10 to 55 Hz (period: 1 min.) frequency, 1.5 mm <b>0.059 in</b> double amplitude in X, Y and Z directions for two hours each   |                                    |   |   |   |
| Shock resistance                |           |            | 500 m/s <sup>2</sup> acceleration (50 G approx.) in X, Y and Z directions three times each  |                                    |   |   |   |
| Cable                           |           |            | 5-core composite cable, 2 m <b>6.5617 ft</b> long   |                                    |   |   |   |
| Cable extension                 |           |            | Extension up to total 10 m <b>32.808 ft</b> is possible with 0.3 mm <sup>2</sup> , or more, cable.  |                                    |   |   |   |
| Material                        |           |            | Enclosure: Aluminum die-cast, Front cover: Acrylic  |                                    |   |   |   |
| Weight                          |           |            | Net weight: 35 g approx. (without cable), 85 g approx. (including cable)  |                                    |   |   |   |

- Notes: 1) Supply voltage: 24 V DC, ambient temperature: +20 °C **+68 °F**, response time: 10 ms, and analog output value of measurement center distance are used for unspecified measurement conditions. The subject is white ceramics.  
 2) This product complies with 21 CFR 1040.10 and 1040.11 Laser Notice No. 50, dated June 24, 2007, issued by CDRH (Center for Devices and Radiological Health) under the FDA (Food and Drug Administration).  
 3) This is the size in the measurement center distance. These values were defined by using 1/e<sup>2</sup> (13.5% approx.) of the center light intensity. Due to leak light outside the specified area, the reflectance around the detecting point may be higher than at the point and this may affect the measurement value.

FIBER  
SENSORSLASER  
SENSORSPHOTO-  
ELECTRIC  
SENSORSMICRO  
PHOTO-  
ELECTRIC  
SENSORSAREA  
SENSORSSAFETY LIGHT  
CURTAINS/  
SAFETY  
COMPONENTSPRESSURE /  
FLOW  
SENSORSINDUCTIVE  
PROXIMITY  
SENSORSPARTICULAR  
USE  
SENSORSSENSOR  
OPTIONSSIMPLE  
WIRE-SAVING  
UNITSWIRE-SAVING  
SYSTEMSMEASURE-  
MENT  
SENSORSSTATIC  
CONTROL  
DEVICESLASER  
MARKERS

PLC

HUMAN  
MACHINE  
INTERFACESENERGY  
MANAGEMENT  
SOLUTIONSFA  
COMPONENTSMACHINE  
VISION  
SYSTEMSUV  
CURING  
SYSTEMSSelection  
GuideAmplifier  
Built-inAmplifier-  
separated

EX-L200

HG-C



FIBER SENSORS  
 LASER SENSORS  
 PHOTO-ELECTRIC SENSORS  
 MICRO PHOTO-ELECTRIC SENSORS  
 AREA SENSORS  
 SAFETY LIGHT CURTAINS / SAFETY COMPONENTS  
 PRESSURE / FLOW SENSORS  
 INDUCTIVE PROXIMITY SENSORS  
 PARTICULAR USE SENSORS  
 SENSOR OPTIONS  
 SIMPLE WIRE-SAVING UNITS  
 WIRE-SAVING SYSTEMS  
 MEASUREMENT SENSORS  
 STATIC CONTROL DEVICES  
 LASER MARKERS  
 PLC  
 HUMAN MACHINE INTERFACES  
 ENERGY MANAGEMENT SOLUTIONS  
 FA COMPONENTS  
 MACHINE VISION SYSTEMS  
 UV CURING SYSTEMS  
 Selection Guide  
 Amplifier Built-in  
 Amplifier-separated  
 EX-L200  
**HG-C**

## I/O CIRCUIT DIAGRAMS

### NPN output type

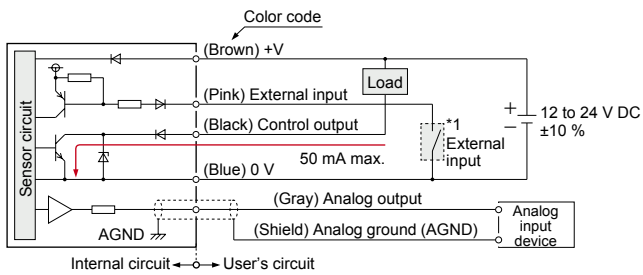

### PNP output type

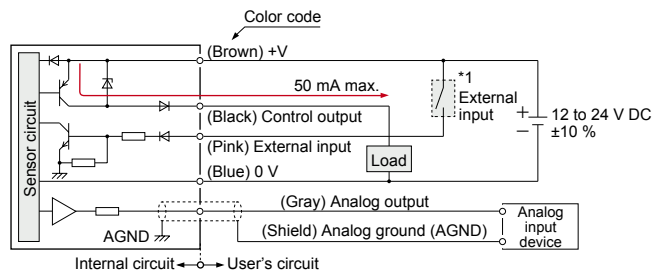

\*1

Non-voltage contact or NPN open-collector transistor

- External input Invalid: +8 V to +V DC or open
- Valid: 0 to +1.2 V DC

\*1

Non-voltage contact or PNP open-collector transistor

- External input Invalid: 0 to +0.6 V DC or open
- Valid: +4 V to +V DC

## SENSING CHARACTERISTICS (TYPICAL)

### Linearity

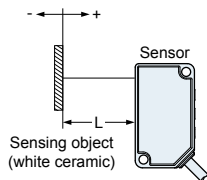

### HG-C1030(-P)

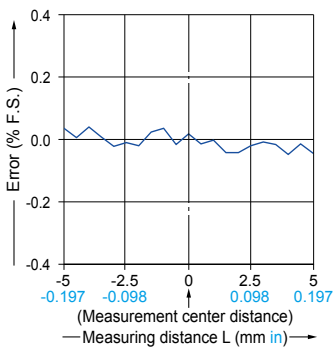

### HG-C1050(-P)

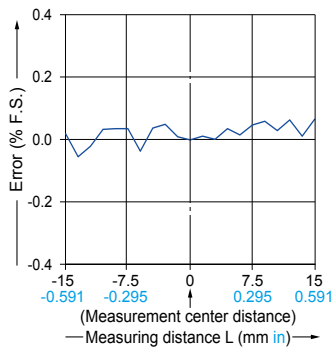

### HG-C1100(-P)

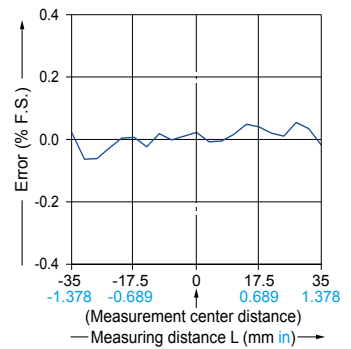

### HG-C1200(-P)

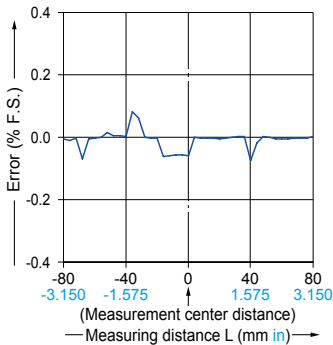

### HG-C1400(-P)

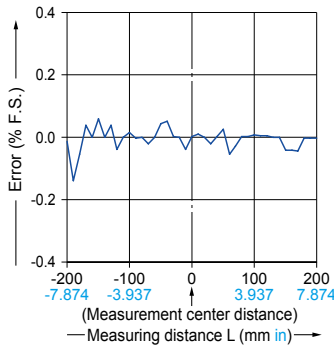

**PRECAUTIONS FOR PROPER USE**

Refer to p.1552~ for general precautions and p.1593~ for information about laser beam.

- This catalog is only provided to help choose a product and the user's guide attached to the product must be read before use.



- Never use this product as a sensing device for personnel protection.
- In case of using sensing devices for personnel protection, use products which meet laws and standards, such as OSHA, ANSI or IEC etc., for personnel protection applicable in each region or country.



- Do not operate products using methods other than the ones described in the instruction manual included with each product. Control or adjustment through procedures other than the ones specified may cause hazardous laser radiation exposure.



- This product is classified as a Class 2 Laser Product under IEC / JIS / GB standards and FDA\* regulations. Do not look at the laser beam directly or through an optical system such as a lens.
- The warning label (English) is attached to the product. Handle the product according to the instruction given on the warning label. (The warning labels in Japanese and Chinese are packed with the sensor.)



\* This product complies with 21 CFR 1040.10 and 1040.11 Laser Notice No. 50, dated June 24, 2007, issued by CDRH (Center for Devices and Radiological Health) under the FDA (Food and Drug Administration).

**Part description**

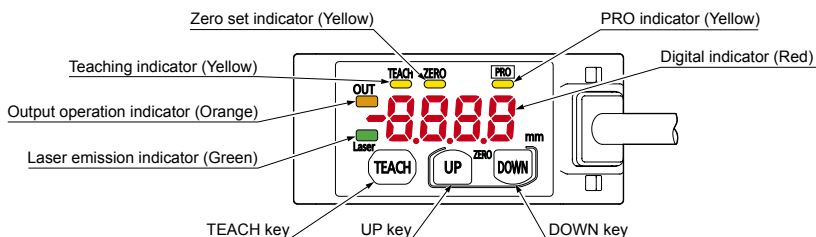

**PRO mode setting**

**Part description**

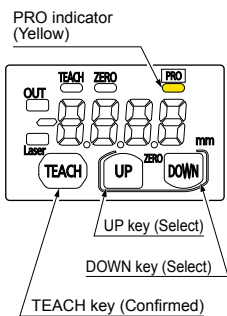

| Item                     | Default setting   | Description   |
|--------------------------|---|---|
| Response time setting    | Hr50  | Set the response time.<br>"Hr50": High precision 10ms, "Std": Standard 5ms, "Fst": High speed 1.5ms   |
| Output operation setting | L-on  | Select the control output operation mode.<br>"L-on": Light-ON, "d-on": Dark-ON  |
| Sensing output setting   | --S-  | Set the sensing output.<br>"--S-": Normal sensing mode<br>"R1": 1-point teaching (Window comparator mode)<br>"R2": 2-point teaching (Window comparator mode)<br>"R3": 3-point teaching (Window comparator mode)<br>"d-f": Rising differential mode<br>"d-l": Trailing differential mode |
| Analog output setting    | volt  | Set the output operation of analog output setting.<br>"volt": Analog voltage output (0 to +5 V)<br>"curr": Analog current output (4 to 20 mA)   |
| Hysteresis setting       | HG-C1030 0010 HG-C1050 003<br>HG-C1100 007 HG-C1200 02<br>HG-C1400 08 | Set the hysteresis width.<br>HG-C1030: 0.001 to 5.00 mm 0.00004 to 0.197 in<br>HG-C1050: 0.01 to 15.00 mm 0.00039 to 0.591 in<br>HG-C1100: 0.02 to 35.00 mm 0.00079 to 1.378 in<br>HG-C1200: 0.1 to 80.0 mm 0.00394 to 3.150 in<br>HG-C1400: 0.2 to 200.0 mm 0.00787 to 7.874 in        |
| External input setting   | 0Set  | Set the external input.<br>"0Set": Zero set function, "Teach": Teaching function<br>"L-off": Light emitting stop function, "Trig": Trigger function   |
| Timer setting            | non   | Set the timer operation. The timer time is fixed at 5ms.<br>"non": No timer, "ofd": OFF-delay timer<br>"ond": ON-delay timer, "osd": One-shot timer   |
| Display setting          | Std   | The display of the measured value can be changed.<br>"Std": Normal, "Inv": Invert, "Ofst": Offset   |
| Hold setting             | off   | Set the control output and the analogue output operation when a measurement error occurs (insufficient light intensity, saturation of light intensity, out of measurement range).<br>"off": Hold OFF, "on": Hold ON   |
| ECO setting              | off   | The digital display can be set to go OFF when key operation is not performed for 30 seconds. Current consumption can be reduced.<br>"off": ECO OFF, "on": ECO ON  |
| Reset setting            | no  | Return to the default setting (factory setting).<br>"no": Reset NG, "YES": Reset OK   |

FIBER SENSORS  
LASER SENSORS  
PHOTO-ELECTRIC SENSORS  
MICRO PHOTO-ELECTRIC SENSORS  
AREA SENSORS  
SAFETY LIGHT CURTAINS / SAFETY COMPONENTS  
PRESSURE / FLOW SENSORS  
INDUCTIVE PROXIMITY SENSORS  
PARTICULAR USE SENSORS  
SENSOR OPTIONS  
SIMPLE WIRE-SAVING UNITS  
WIRE-SAVING SYSTEMS  
MEASUREMENT SENSORS  
STATIC CONTROL DEVICES  
LASER MARKERS  
PLC  
HUMAN MACHINE INTERFACES  
ENERGY MANAGEMENT SOLUTIONS  
FA COMPONENTS  
MACHINE VISION SYSTEMS  
UV CURING SYSTEMS  
Selection Guide  
Amplifier Built-in  
Amplifier-separated

EX-L200

HG-C

**PRECAUTIONS FOR PROPER USE**

Refer to p.1552~ for general precautions and p.1593~ for information about laser beam.

**Procedure**

Measurement display

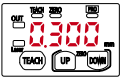

DOWN: Press for 3 seconds

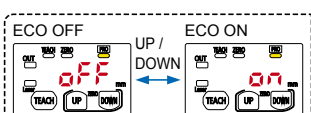
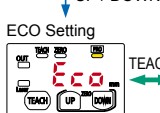
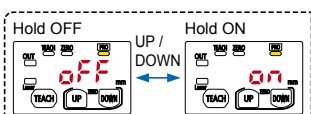
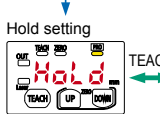
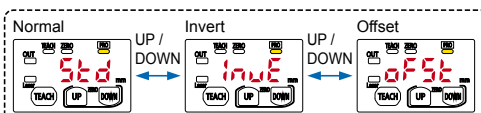
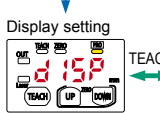
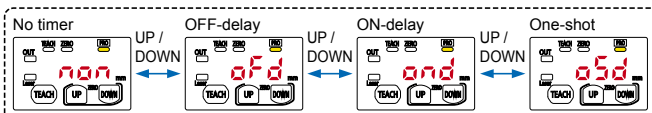
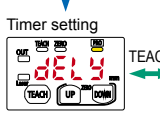
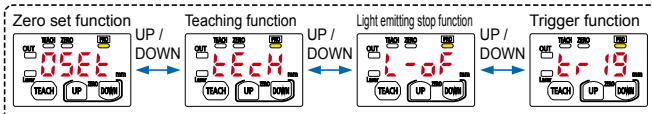
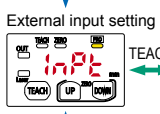
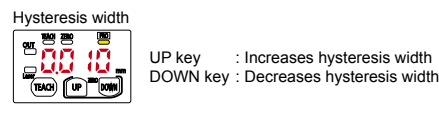
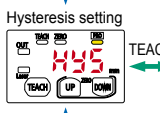
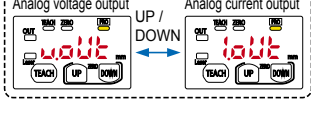
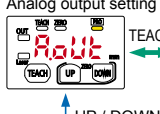
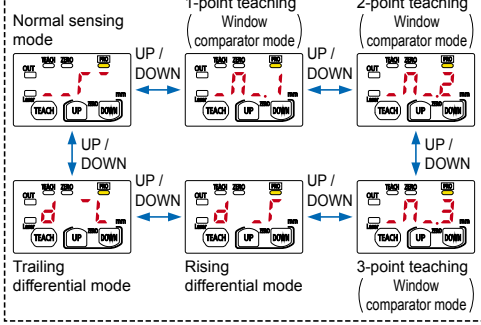
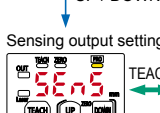
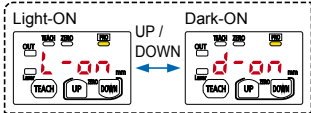
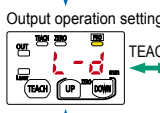
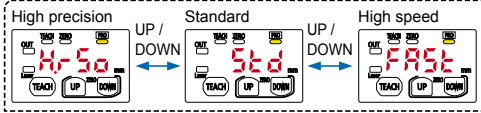
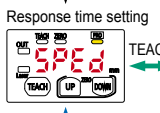

**<Arrow description in figures>**

- ↔ : Press the TEACH key
- ↑ / ↓ : Press UP key or DOWN key
- ← / → : Press DOWN key

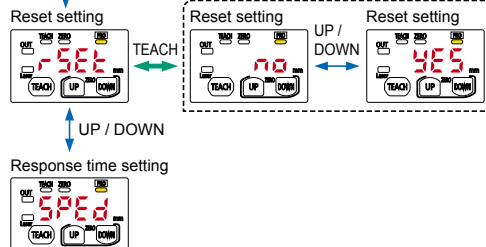

FIBER SENSORS  
LASER SENSORS  
PHOTO-ELECTRIC SENSORS  
MICRO PHOTO-ELECTRIC SENSORS  
AREA SENSORS  
SAFETY LIGHT CURTAINS / SAFETY COMPONENTS  
PRESSURE / FLOW SENSORS  
INDUCTIVE PROXIMITY SENSORS  
PARTICULAR USE SENSORS  
SENSOR OPTIONS  
SIMPLE WIRE-SAVING UNITS  
WIRE-SAVING SYSTEMS  
MEASURE-MENT SENSORS  
STATIC CONTROL DEVICES  
LASER MARKERS  
PLC  
HUMAN MACHINE INTERFACES  
ENERGY MANAGEMENT SOLUTIONS  
FA COMPONENTS  
MACHINE VISION SYSTEMS  
UV CURING SYSTEMS  
Selection Guide  
Amplifier Built-in  
Amplifier-separated  
EX-L200  
HG-C

**PRECAUTIONS FOR PROPER USE**

Refer to p.1552~ for general precautions and p.1593~ for information about laser beam.

**Mounting**

- When mounting this product, use M3 screws. The tightening torque should be 0.5 N·m. Please prepare M3 screws separately.

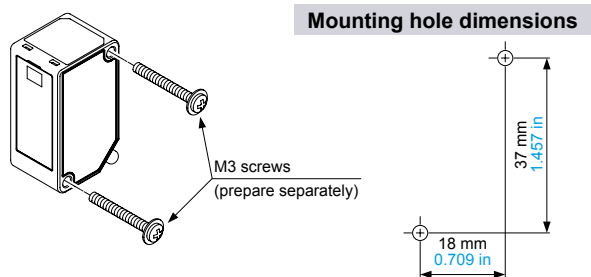

- When mounting the simple mounting bracket (optional) on this product, the tightening torque should be 0.5 N·m or less.

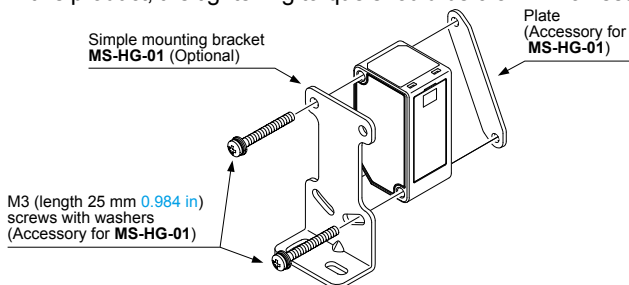

Note: Due to the simple mounting bracket, the sensing characteristics may not be hold depending on the installation condition, in case of the purposes for acquiring the displacement data and a fine detecting.

**Mounting direction**

- **Direction to a movable body**
- <When there are differences in material and color>
- When performing measurements of moving objects with excessively different materials and colors, mount the product per the following directions to minimize measurement errors.

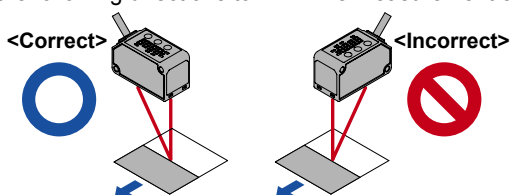

**<Measurement of rotating objects>**

- When measuring rotating objects, mount the product as follows. Measurement can be performed with minimized effect on the object caused by up / down deflection, position deviation and etc.

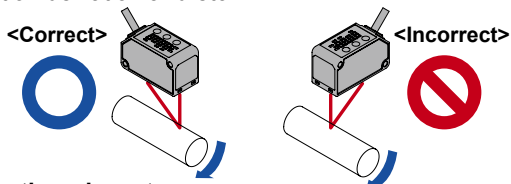

**<When there is a step>**

- When there is a step in the moving object, mount the product as follows. Measurement can be performed with minimized effect from the edges of the steps.

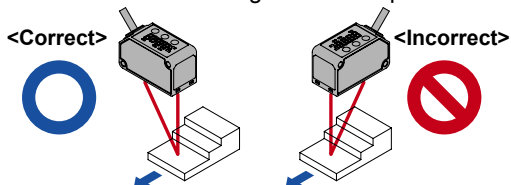

**• Measuring of narrow locations and recesses**

- When measuring in narrow locations or inside holes, mount the product so that optical path from the light-emitting part to light-receiving part is not interrupted.

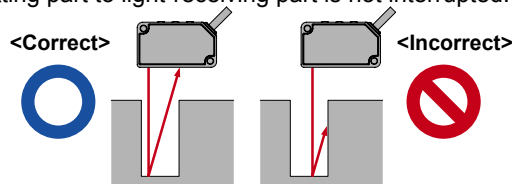

**• When mounting the product on a wall**

- Mount the product as follows, so that the multiple light reflections on the wall do not emit to the light-receiving part. When the reflection factor on a wall is high, it is effective to use a dull black color.

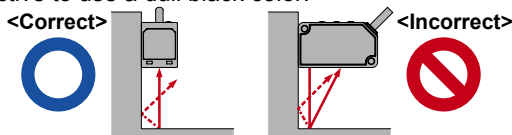

**Others**

- This product has been developed / produced for industrial use only.
- Make sure that the power supply is OFF before starting the wiring.
- If the wiring is performed incorrectly, it will cause a failure.
- Do not run the wires together with high-voltage lines or power lines, or put them in the same raceway. This can cause malfunction due to induction.
- Verify that the supply voltage variation is within the rating.
- If power is supplied from a commercial switching regulator, ensure that the frame ground (F.G.) terminal of the power supply is connected to an actual ground.
- If noise generating devices (switching regulators, inverter motors, etc.) are used around the sensor mounting area, make sure to connect the frame ground (F.G.) terminal of the device.
- Do not use this product during the transient state when the power supply is turned ON.
- Extension up to total 10 m 32.808 ft is possible with 0.3 mm<sup>2</sup> , or more, cable.
- Make sure that stress by forcible bend or pulling is not applied to the sensor cable joint.
- Take care that the sensor is not directly exposed to fluorescent lamp from a rapid-starter lamp or a high frequency lighting device, as it may affect the sensing performance.
- This product is suitable for indoor use only.
- Keep water, oil, fingerprints and etc. which reflect light, or dust, particles or etc. which interrupts the light, away from the emitting/receiving surfaces of this product. If contaminants adhere to the surface, wipe off with a dust-free soft cloth, or lens cleaning paper.
- Do not use the sensor in locations where there is excessive vapor, dust or etc. or in an atmosphere where corrosive gases, etc. is generated.
- Take care that the product does not come in contact with oil, grease, organic solvents such as thinner, etc., strong acid or alkaline.
- Make sure to turn OFF the power supply, before cleaning the light emitting/receiving windows of the sensor head.
- There is a certain deviation in the directionality of this product. Install the product using a mounting bracket or similar fitting to allow the adjustment of optical axis.
- The internal memory (nonvolatile) of this product has a service life. Settings cannot be configured more than 100,000 times.

FIBER SENSORS

LASER SENSORS

PHOTO-ELECTRIC SENSORS

MICRO PHOTO-ELECTRIC SENSORS

AREA SENSORS

SAFETY LIGHT CURTAINS / SAFETY COMPONENTS

PRESSURE / FLOW SENSORS

INDUCTIVE PROXIMITY SENSORS

PARTICULAR USE SENSORS

SENSOR OPTIONS

SIMPLE WIRE-SAVING UNITS

WIRE-SAVING SYSTEMS

MEASURE-MENT SENSORS

STATIC CONTROL DEVICES

LASER MARKERS

PLC

HUMAN MACHINE INTERFACES

ENERGY MANAGEMENT SOLUTIONS

FA COMPONENTS

MACHINE VISION SYSTEMS

UV CURING SYSTEMS

Selection Guide

Amplifier Built-in

Amplifier-separated

EX-L200

HG-C

**PRECAUTIONS FOR PROPER USE**

Refer to p.1552~ for general precautions and p.1593~ for information about laser beam.

**Error indication**

• In case of errors, attempt the following measures.

| Error indication  | Description  | Remedy  |
|---|--|---|
| <Hold OFF><br>-----<br><Hold ON><br>Measured value blinks | Insufficient amount of reflected light.<br>The sensing object is out of the sensing range.   | Confirm that the sensing distance is within the specification range.<br>Adjust the installation angle of the sensor.  |
| E-01  | Flash memory is damaged or is past its life expectancy.  | Please contact our office.  |
| E-11  | Load of the sensing output is short-circuited causing an over-current to flow.   | Turn OFF the power and check the load.  |
| E-21  | The semiconductor laser is damaged or is past its life expectancy.   | Please contact our office.  |
| E-31  | <ul style="list-style-type: none"> <li>When zero set is set, the measurement is not performed normally.</li> <li>Since the display setting is set to "Offset", the zero set function can not be used.</li> </ul> | <ul style="list-style-type: none"> <li>Confirm that the sensing distance is within the specification range.</li> <li>Set the display to any setting except "Offset."</li> </ul> |
| E-41  | During teaching, the measurement is not performed normally.  | Confirm that the sensing distance is within the specification range.  |
| E-90<br>E-91<br>E-92<br>E-93                              | System error   | Please contact our office.  |

**DIMENSIONS (Unit: mm in)**

The CAD data can be downloaded from our website.

**HG-C□**

Sensor

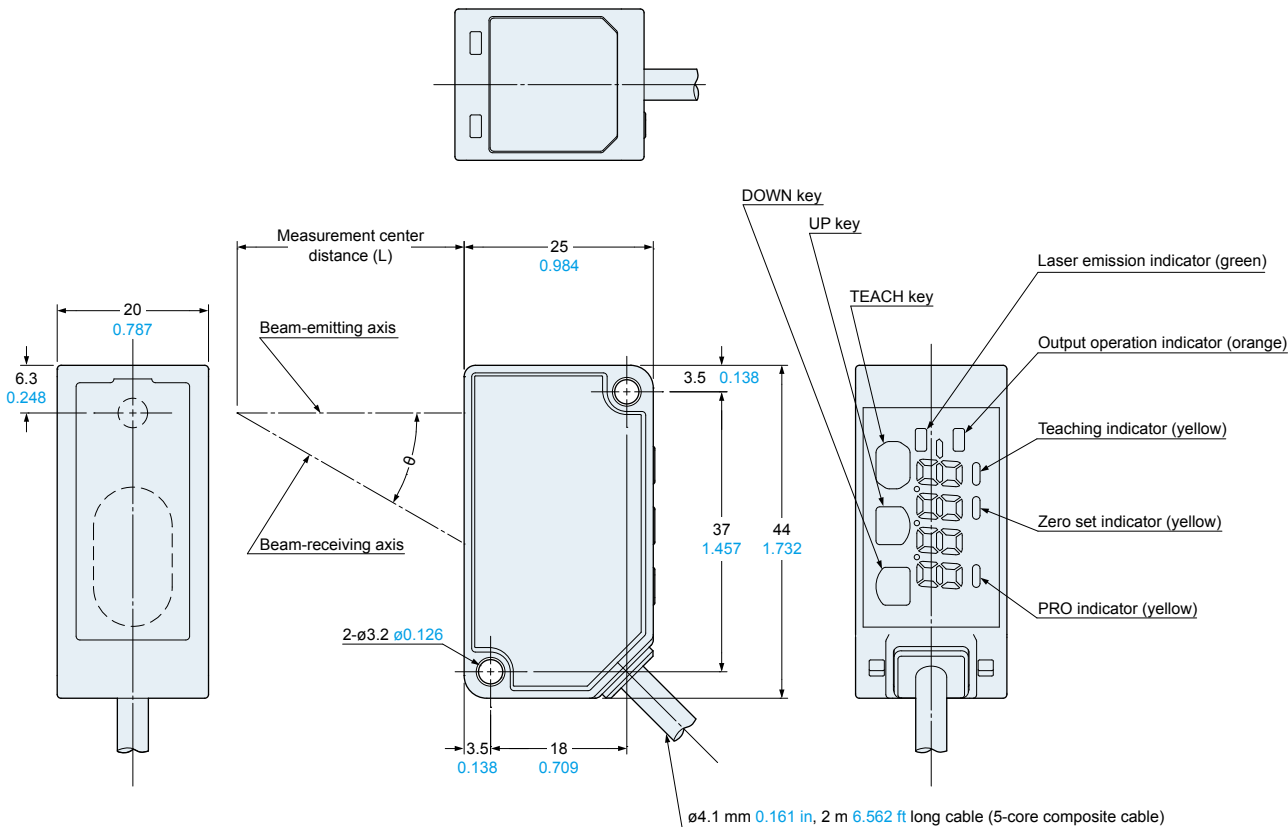

| Model No.    | Measurement center distance (L) | θ     |
|--------------|---------------------------------|-------|
| HG-C1030(-P) | 30 1.181                        | 30°   |
| HG-C1050(-P) | 50 1.969                        | 22.5° |
| HG-C1100(-P) | 100 3.937                       | 12.5° |
| HG-C1200(-P) | 200 7.874                       | 6.3°  |
| HG-C1400(-P) | 400 15.748                      | 3.2°  |

**DIMENSIONS (Unit: mm in)**

The CAD data can be downloaded from our website.

**MS-HG-01**

Simple mounting bracket (Optional)

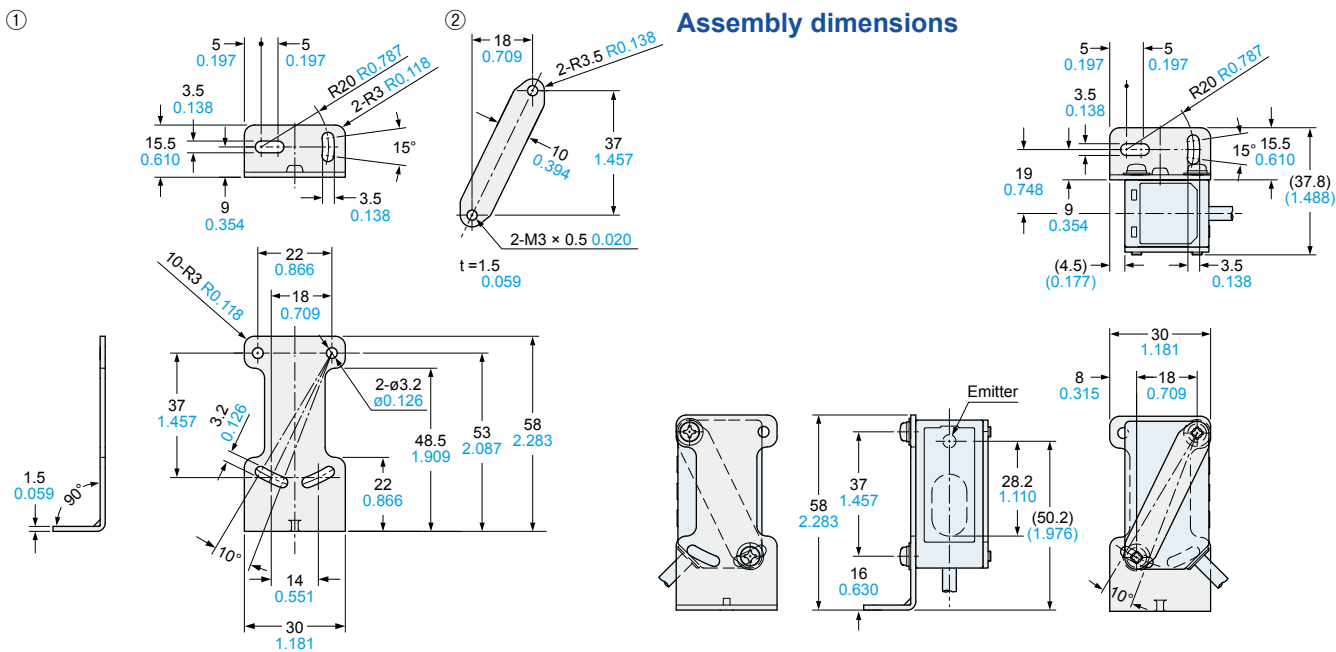

Material: Stainless steel (SUS304)  
 Two M3 (length 25 mm 0.984 in) screws with washers [cold rolled carbon steel (SPCC)] are attached.

FIBER  
ELECTRIC  
SENSORS

LASER  
SENSORS

PHOTO-  
ELECTRIC  
SENSORS

MICRO  
PHOTO-  
ELECTRIC  
SENSORS

AREA  
SENSORS

SAFETY LIGHT  
CURTAINS/  
SAFETY  
COMPONENTS

PRESSURE /  
FLOW  
SENSORS

INDUCTIVE  
PROXIMITY  
SENSORS

PARTICULAR  
USE  
SENSORS

SENSOR  
OPTIONS

SIMPLE  
WIRE-SAVING  
UNITS

WIRE-SAVING  
SYSTEMS

MEASURE-  
MENT  
SENSORS

STATIC  
CONTROL  
DEVICES

LASER  
MARKERS

PLC

HUMAN  
MACHINE  
INTERFACES

ENERGY  
MANAGEMENT  
SOLUTIONS

FA  
COMPONENTS

MACHINE  
VISION  
SYSTEMS

UV  
CURING  
SYSTEMS

Selection  
Guide

Amplifier  
Built-in

Amplifier-  
separated

EX-L200

HG-C

单击下面可查看定价，库存，交付和生命周期等信息

[>>Panasonic\(松下\)](#)