

Approved	Checked	Designed	DEVELOPMENT SPECIFICATION				
		<i>K. Oshino</i>		P/N: LN1871Y5TRP			

T Y P E	Soft Orange Light Emitting Diode					
APPLICATION	Indicators					
MATERIAL	GaAsP					
OUTLINE	Attached					
ABSOLUTE MAXIMUM RATINGS	P	※ I _{FP}	I _{FDC}	V _R	Topr	Tstg
	60	60	20	3	-25~+85	-30~+100
	mW	mA	mA	V	°C	°C
CONDITION	T _a = 25 ± 3 °C					

Test Specification

Item	Symbol	Condition	Typ	Limit		Unit
				Min	Max	
Forward Voltage	V _F	I _F = 10 mA	1.93		2.6	V
Reverse Leakage Current	I _R	V _R = 3 V			10	μA
Luminous Intensity	I _O	I _F = 10 mA · DC	0.8	0.3		mcd
Peak Emission Wavelength	λ _p	I _F = 10 mA · DC	610			nm
Spectral Line Half Width	Δλ	I _F = 10 mA · DC	40			nm

- ※ · The Condition of I_{FP} is duty 10 %, Pulse width 1 ms
- Please contact the Panasonic local office if you design at low current (below 1mA DC) or pulse current operation and have any questions.

NOTE

1. Compositions of the lead ... Cu/Ni/Au plating
2. Soldering conditions.
Refer to Handling note.
3. Care should be taken that soldering is done within 3-days after opening the dry package and reel.
4. Package: Light yellow diffusion type.
5. Circuit to operate LED.

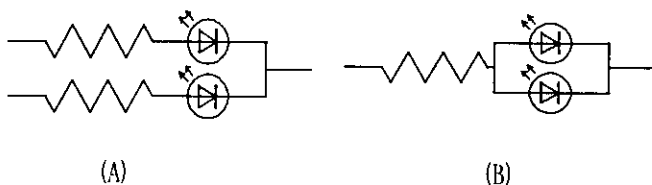

- (A) Recommended circuit.
- (B) The difference of brightness between the LED could be found due to the V_F characteristics of each LED.

Oct. 27. 2001			

K. Ozawa

P/N: LN1871Y5TRP

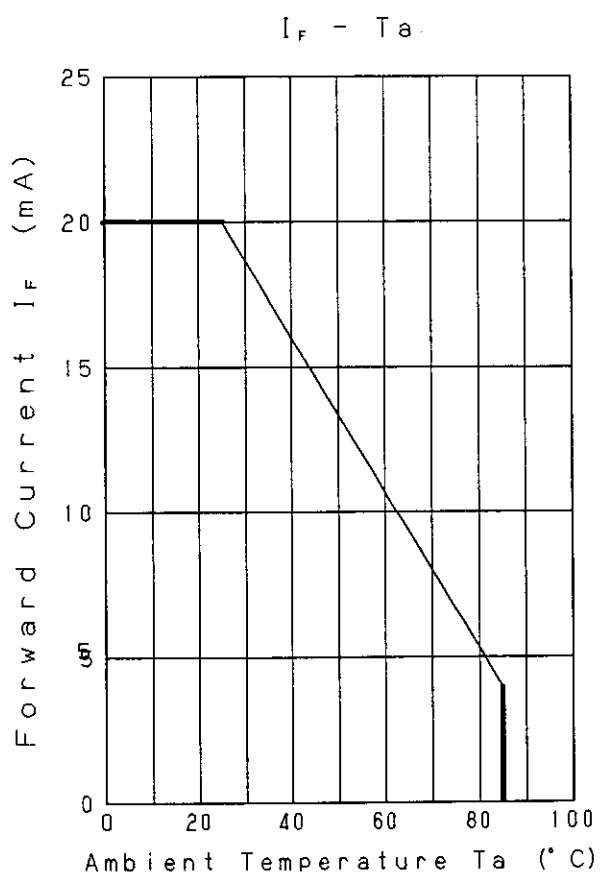
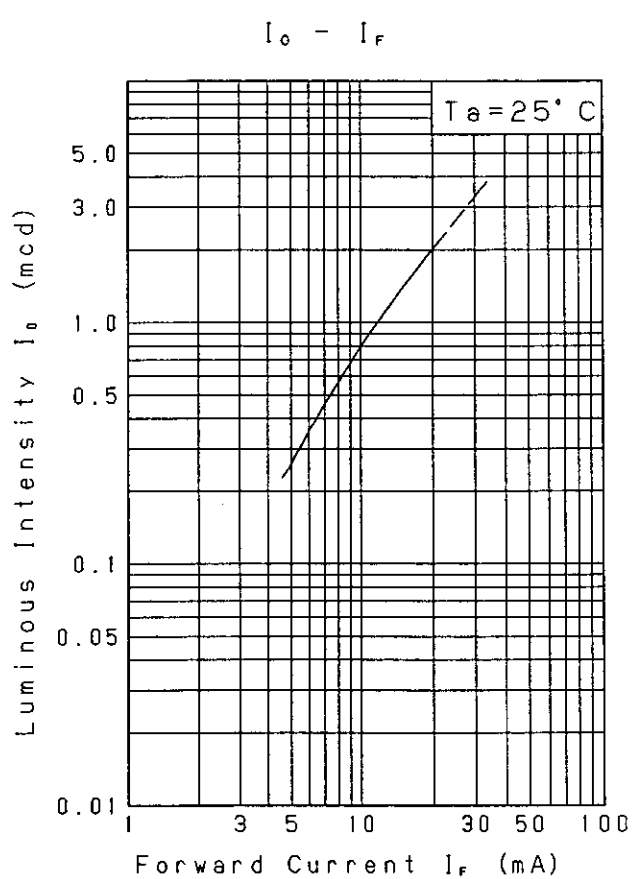
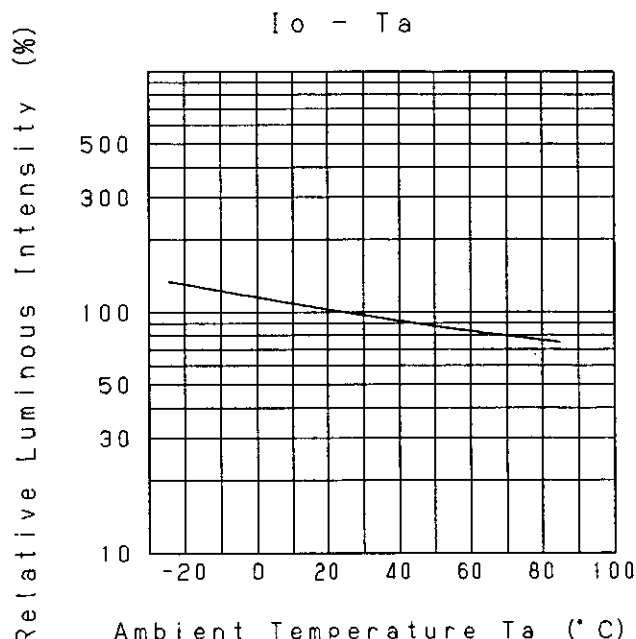
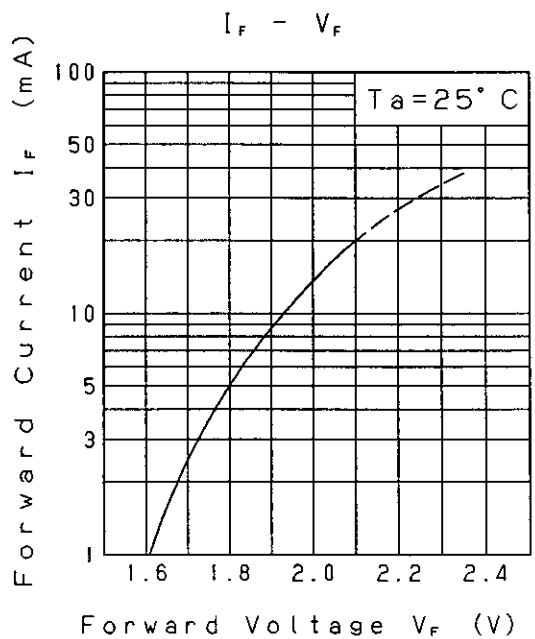

Oct. 27. 2001

K. Oshino

P/N: LN1871Y5TRP

Relative Luminous Intensity
Wavelength Characteristics

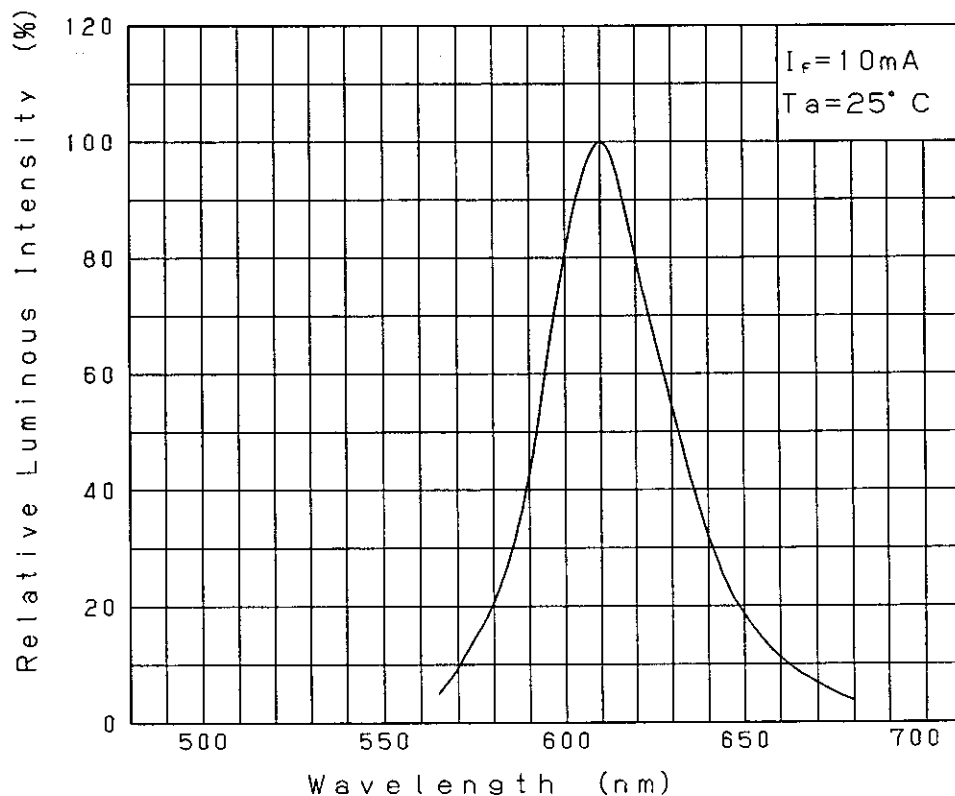

Directive Characteristics

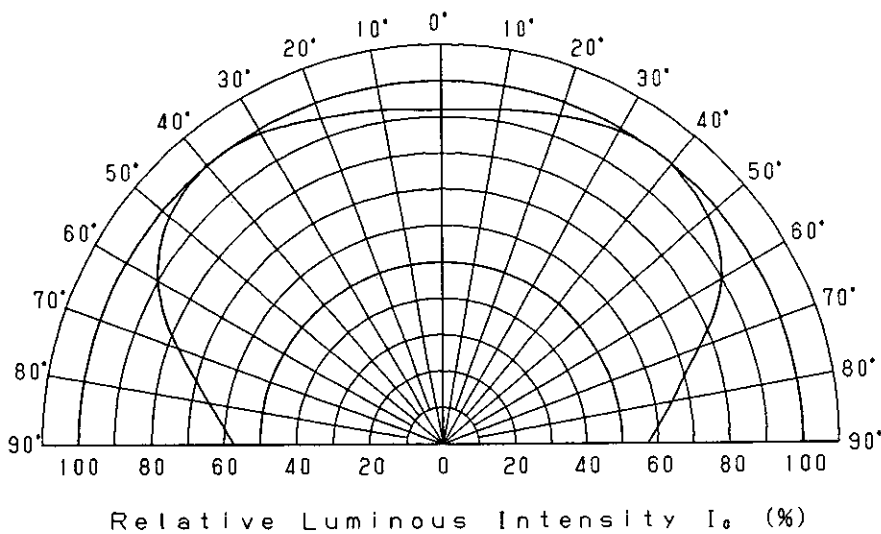

Oct. 27. 2001

Approved	Checked	Designed
		<i>K. Ohtani</i>

DEVELOPMENT SPECIFICATION
(OUTLINE)

P/N: LN1871Y5TRP

--	--	--

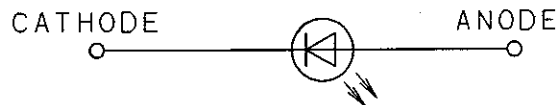
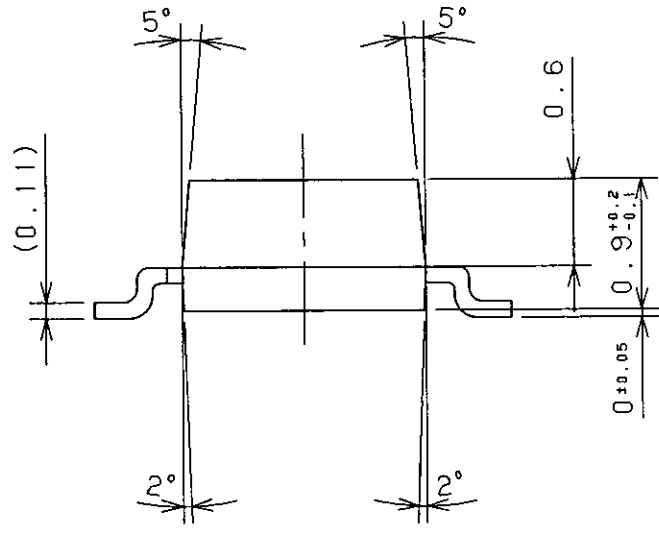
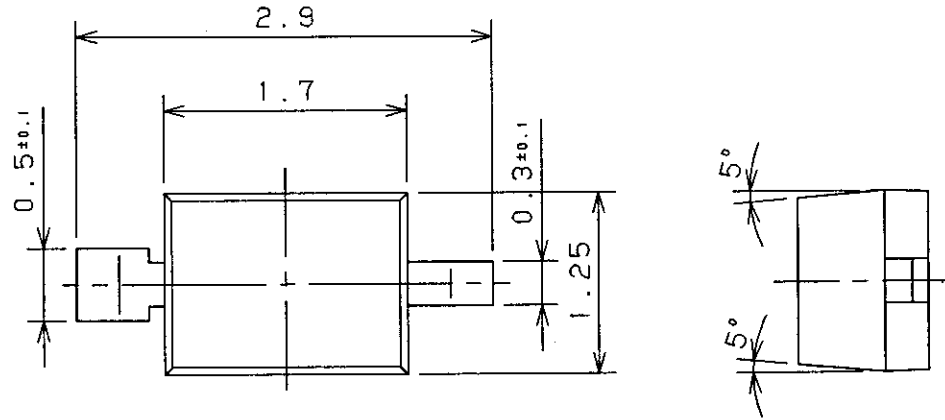

- (NOTE)
1. Unit: mm
 2. Tolerance unless specified is ± 0.2 .
 3. Measurement of the Package doesn't include gage projection.
 4. Corner of the package is R 0.2 max.
 5. Projection's tolerance of the package is R 0.2 max.

Oct. 27. 2001

单击下面可查看定价，库存，交付和生命周期等信息

[>>Panasonic\(松下\)](#)