

Approved	Checked	Designed	DEVELOPMENT SPECIFICATION			
<i>T. Ikeda</i>	<i>M. Hoji</i>	<i>J. Horiguchi</i>	P/N: <u>LNJ010X6FRA</u>			

## DEVELOPMENT SPECIFICATION

PRODUCT NUMBER                      LNJ010X6FRA

PRODUCT NAME                        Side view type chip LED

PUBLISH                                      Oct. 2. 2002

KAGOSHIMA MATSUSHITA ELECTRONICS CO., LTD.  
Development Center

Oct. 2. 2002	Feb.17.2003		

Approved	Checked	Designed	DEVELOPMENT SPECIFICATION				
<i>T. Sheda</i>	<i>M. H.</i>	<i>J. Haniguchi</i>		<u>P/N: LNJ010X6FRA</u>			

7. Others

7-1 Caution on use

Refer to Handling note.

7-2 Caution on design

1 Connect the current control resistor in the circuit so it operates within ratings.

2 An instant reverse voltage (reverse current) when turning on/off the circuit should be avoided.

3 Mount the chip in longitudinal direction of the board so that stress on product is decreased.

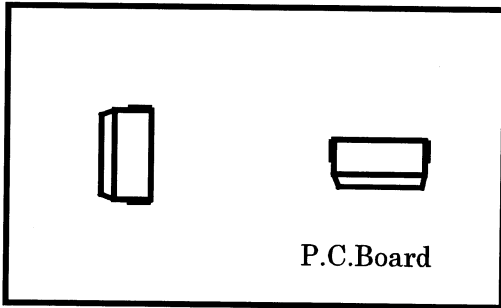

(A)

(B)

【NOTE】

- We recommend the LED be placed on the PC Board as shown in diagram A.
- If the LED must be placed on the PC Board as shown in diagram B, special care should be taken to insure that the LED is not effected by bend of the PC Board after the soldering process.

7-3 UL standard

Since epoxy resin which is superior in optical characteristics is Adopted for the LED, UL standard is not gained.

7-4 Doubt

If any doubt arises as to this specification, it should be solved by mutual consultation.

7-5 Although it is ensured that products satisfying every item in this specification are delivered, for installation, life on practical use and other quality, please examine the products yourself completely.

7-6 These parts are intended to be used for general commercial applications. Please contact your local Panasonic sales office prior to these components being used in applications where failure of a component could lead to serious risk of personal injury or property damage.

Oct. 2. 2002			

Approved	Checked	Designed	<b>DEVELOPMENT SPECIFICATION</b>  <u>P/N: LNJ010X6FRA</u>																
<i>T. Shoda</i>	<i>M. Ichi</i>	<i>Y. Haniguchi</i>																	
<p>1. Scope of application This specification applies to "LNJ010X6FRA" of side view type chip LED series.</p> <p>2. Ratings and characteristics Refer to attached development specification.</p> <p>3. Overview Refer to attached drawing of overview.</p> <p>4. Packing Refer to attached packing specification. ※However if the number of products does not reach a package unit or delivery containing apparently short number of products is required packing may differ.</p> <p>5. Indication Name of product, quantity, serial tight number should be identified on the Individual package.  <div style="margin-left: 40px;"> <u>20</u>                      <u>Oct. 2002</u>  <span style="margin-left: 100px;">⇒</span> </div> <table style="margin-left: 40px; border: none;"> <tr> <td>January</td> <td>February</td> <td>.....</td> <td>October</td> <td>November</td> <td>December</td> </tr> <tr> <td style="text-align:center;">1</td> <td style="text-align:center;">2</td> <td style="text-align:center;">.....</td> <td style="text-align:center;">O</td> <td style="text-align:center;">N</td> <td style="text-align:center;">D</td> </tr> </table> <p style="margin-left: 40px;">*Only on the packing case tight number can be contained.</p> <p>6. External inspection Those defects such as crack, breakage, scar and void which affect optical and Mechanical characteristics should be failed.</p> </p>								January	February	.....	October	November	December	1	2	.....	O	N	D
January	February	.....	October	November	December														
1	2	.....	O	N	D														
Oct. 2. 2002																			

Approved <i>T. Shoda</i>	Checked <i>M. Imai</i>	Designed <i>M. Hattaguchi</i>	DEVELOPMENT SPECIFICATION			
			P/N: LNJ010X6FRA			

T Y P E	White Light Emitting Diode					
A P P L I C A T I O N	Indicators					
M A T E R I A L	GaN					
O U T L I N E	Attached					

A B S O L U T E M A X I M U M R A T I N G S	P	$I_{FDC}$	*1 $I_{FP}$	$I_{RDC}$	$T_{opr}$	$T_{stg}$
	120	30	80	100	-25~+80	-30~+85
	mW	mA	mA	mA	°C	°C

CONDITION	$T_a = 25 \pm 3 \text{ } ^\circ\text{C}$					
-----------	--	--	--	--	--	--

Test Specification

Item	Symbol	Condition	Typ.	Limit		Unit
				Min.	Max.	
Forward Voltage	$V_F$	$I_F = 20 \text{ mA} \cdot \text{DC}$	3.4	2.8	3.9	V
Reverse Leakage Current	$V_R$	$I_R = 10 \text{ mA}$			(2.5)	$\mu\text{A}$
Luminous Intensity *2	$I_O$	$I_F = 20 \text{ mA} \cdot \text{DC}$	260	180	337	mcd
Chromatic coordinates	x	$I_F = 20 \text{ mA} \cdot \text{DC}$		0.261	0.357	-
	y	$I_F = 20 \text{ mA} \cdot \text{DC}$		0.242	0.375	-

- \*1 • The Condition of  $I_{FP}$  is duty 10 %, Pulse width 1 ms.
- Please contact the Panasonic local office if you design at low current (below 1 mA DC) or pulse current operation and have any questions.
- \*2 • Rank classification of luminous intensity is performed at 20mA of forward current.
- Tolerance of luminous intensity is  $\pm 20 \%$ .

Rank	Luminous Intensity (mcd)
4	180 ~ 238
5	238 ~ 278
6	278 ~ 337

- NOTE
1. Soldering conditions. Refer to Handling note.
  2. Care should be taken that soldering is done within 3-days after opening the dry package and reel.

Circuit model

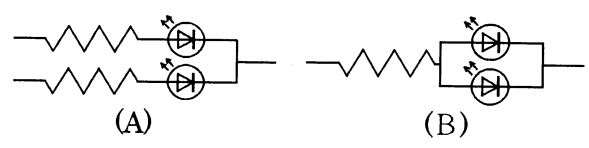

(A) Recommended circuit.  
 (B) The difference of brightness between the LED could be found due to the  $V_F$  characteristics of each LED.

Oct. 2. 2002	Feb. 17. 2003		
--------------	---------------	--	--

Approved	Checked	Designed	DEVELOPMENT SPECIFICATION				
<i>T. Shoda</i>	<i>h. w.</i>	<i>y. Horiguchi</i>		P/N: LNJO10X6FRA			

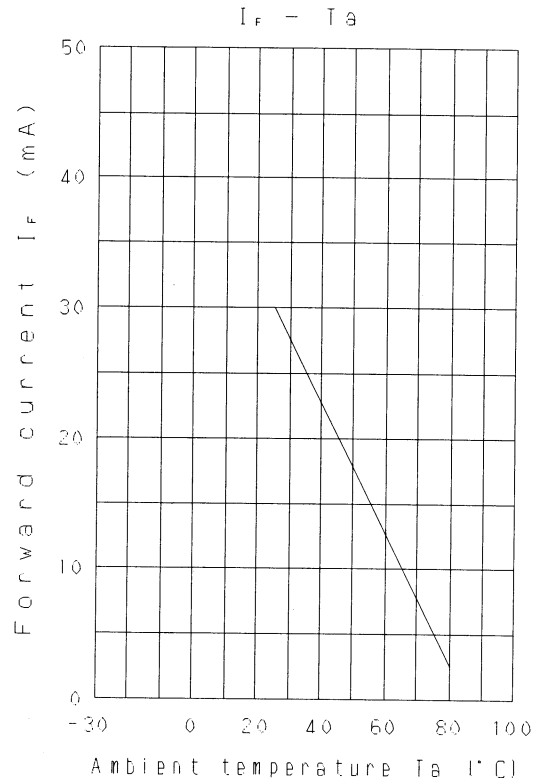
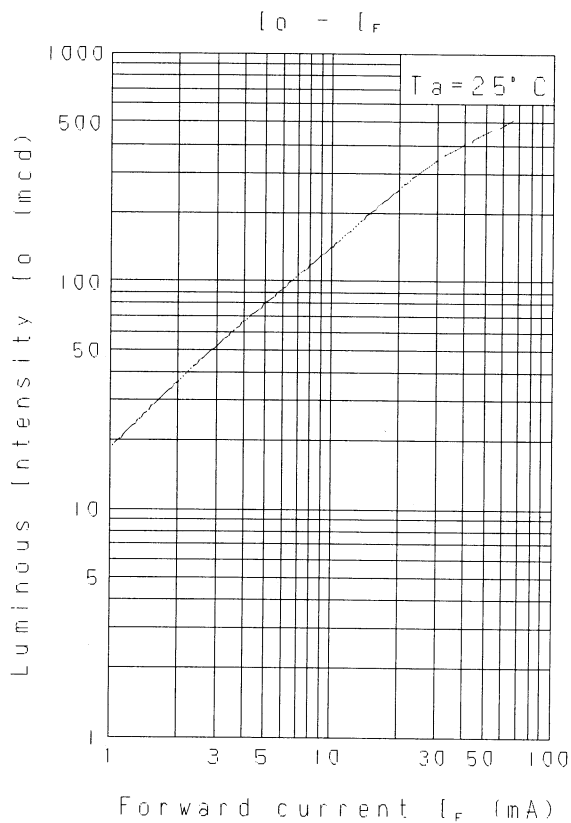
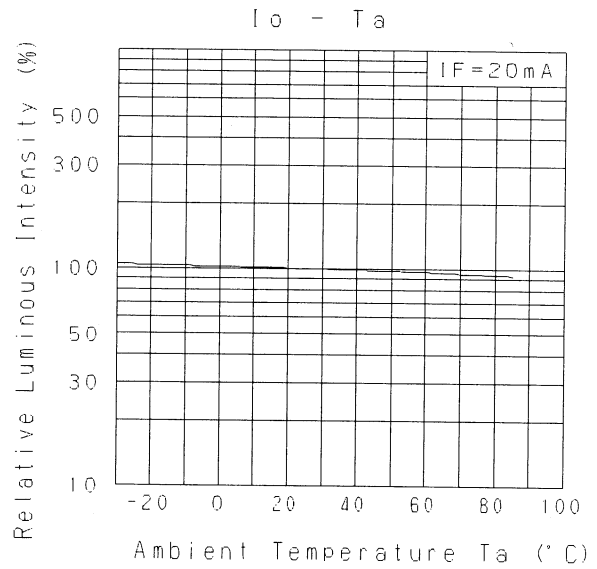
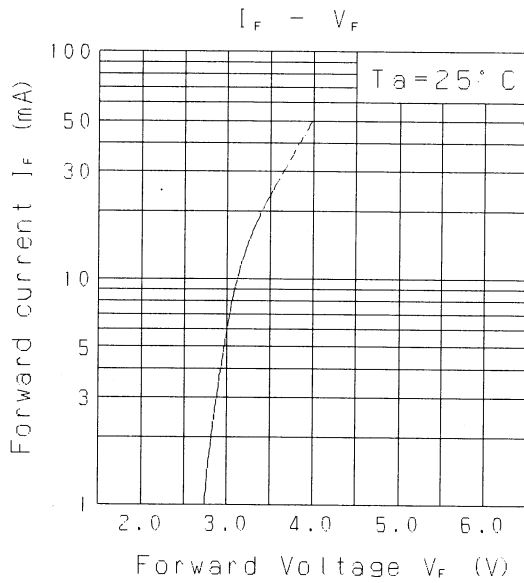

Oct. 2. 2002	Feb. 17. 2003		

Approved	Checked	Designed	DEVELOPMENT SPECIFICATION				
<i>T. Shoda</i>	<i>M. Kojima</i>	<i>Y. Horiguchi</i>		P/N: LN J 0 1 0 X 6 F R A			

Classification of Chromatic coordinates

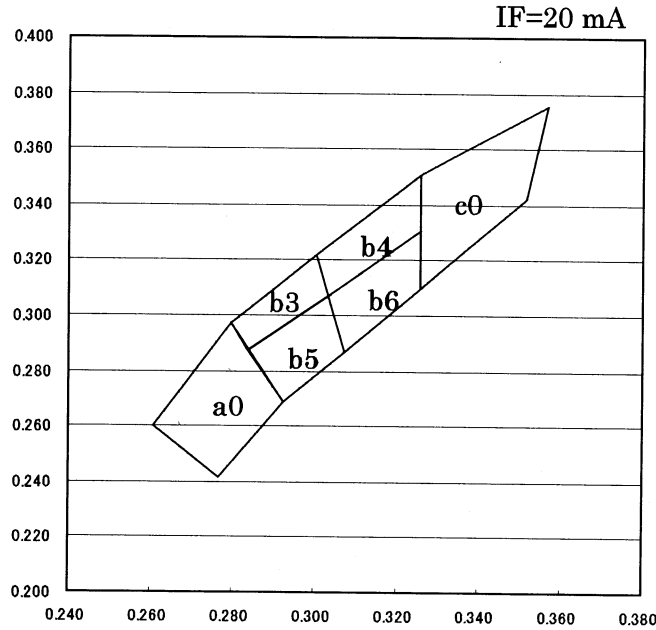

	x	y
a0	0.277	0.242
	0.292	0.269
	0.280	0.297
	0.261	0.260
b3	0.283	0.288
	0.303	0.307
	0.300	0.322
	0.280	0.297
b4	0.303	0.307
	0.326	0.331
	0.326	0.351
	0.300	0.322

	x	y
b5	0.292	0.269
	0.307	0.287
	0.303	0.307
	0.283	0.288
b6	0.307	0.287
	0.326	0.310
	0.326	0.331
	0.303	0.307
c0	0.326	0.310
	0.352	0.342
	0.357	0.375
	0.326	0.351

1. Chromatic coordinates will change by the level of operating current.
2. 6ranks classification of chromatic coordinates is available.
3. Tolerance of chromatic coordinates mesurement is  $\pm 0.02$ .

Oct. 2. 2002			

Approved	Checked	Designed	DEVELOPMENT SPECIFICATION				
<i>T. Cheda</i>	<i>M. G.</i>	<i>Y. H. H.</i>					

### Directive Characteristics

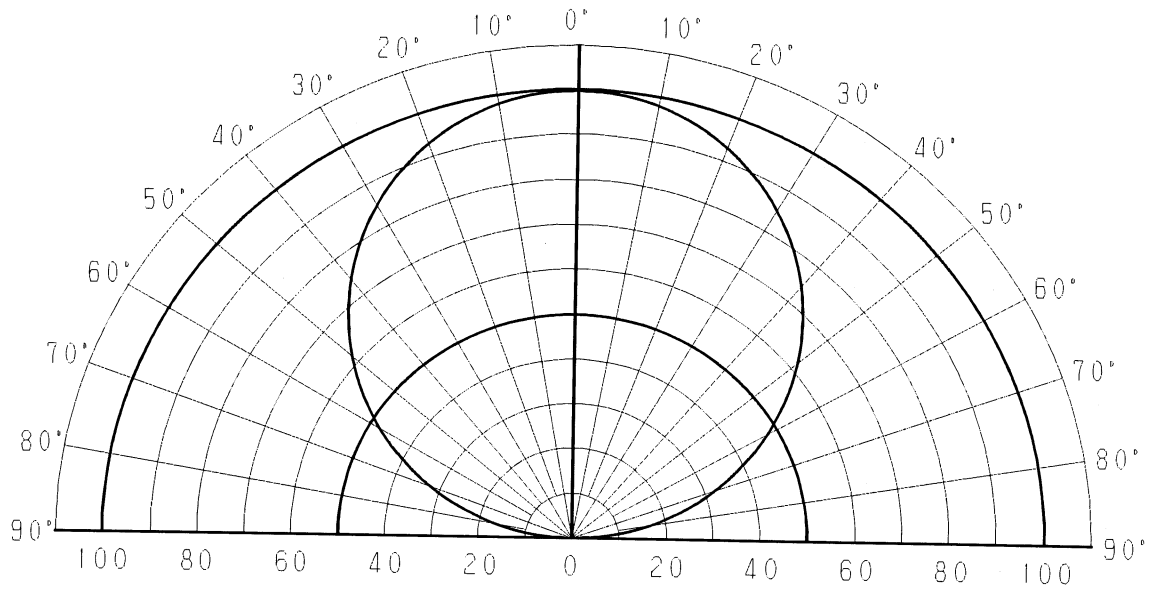

Relative Luminous Intensity (%)

Oct. 2. 2002			

Approved	Checked	Designed	DEVELOPMENT SPECIFICATION
<i>T. Ikeda</i>	<i>M. W.</i>	<i>A. Hasegawa</i>	
			P/N : LN J 0 1 0 X 6 F R A

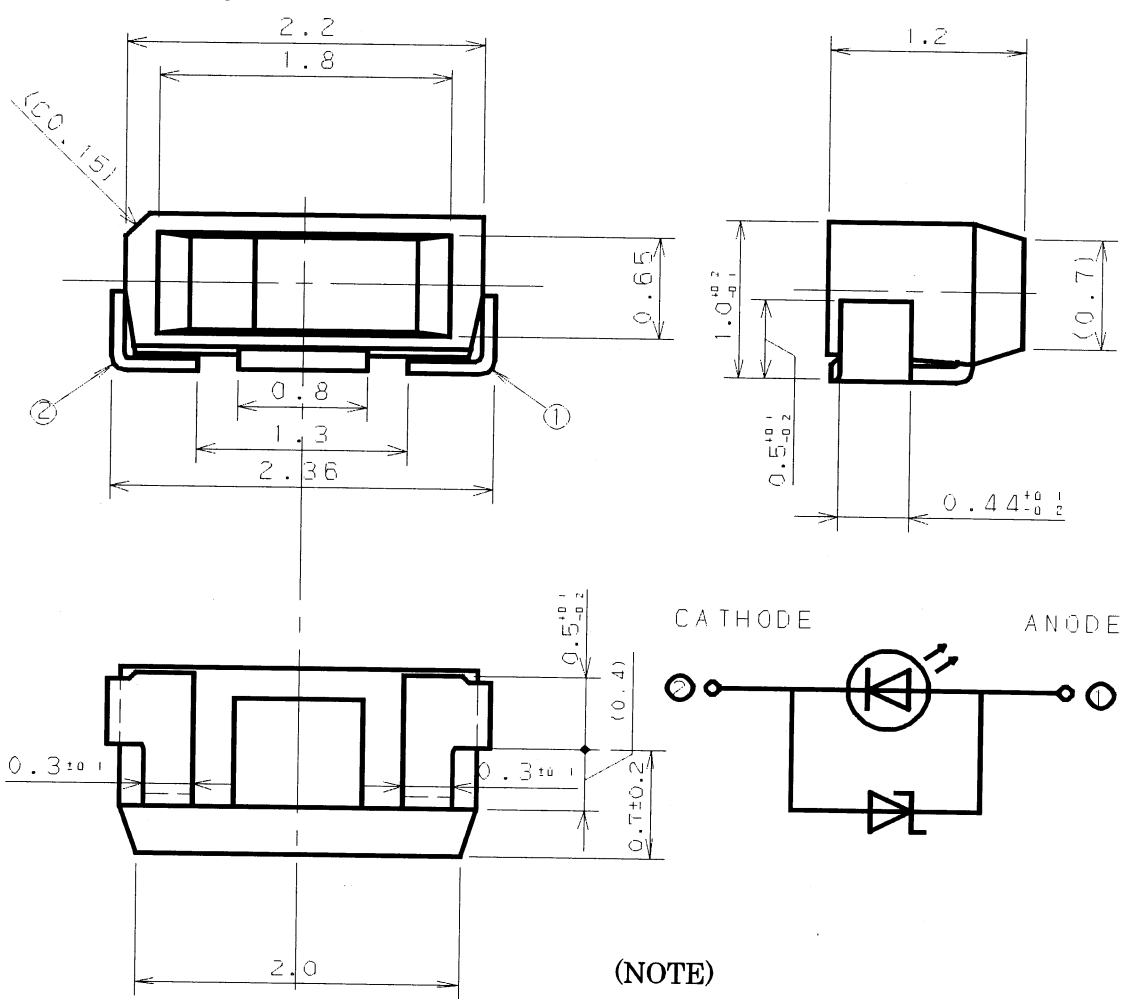

**Recommended Land Layout**

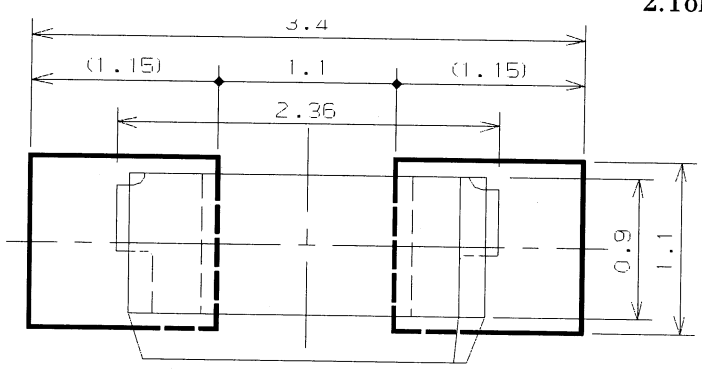

- (NOTE)
1. Unit : mm
  2. Tolerance unless specified is  $\pm 0.15$ .

Oct. 2. 2002			
--------------	--	--	--



Approved	Checked	Designed	DEVELOPMENT SPECIFICATION				
<i>T. Ikeda</i>	<i>M. H.</i>	<i>T. Higuchi</i>		P/N: LNJO10X6FRA			

**~Taping Specifications~**

1. Scope of application

This specification regulates packing and related matters as to taping delivery of chip type visible LED (called chip LED hereinafter).  
Refer to the individual product specification for items not contained herein such as electric characteristics.

2. Structure of taping

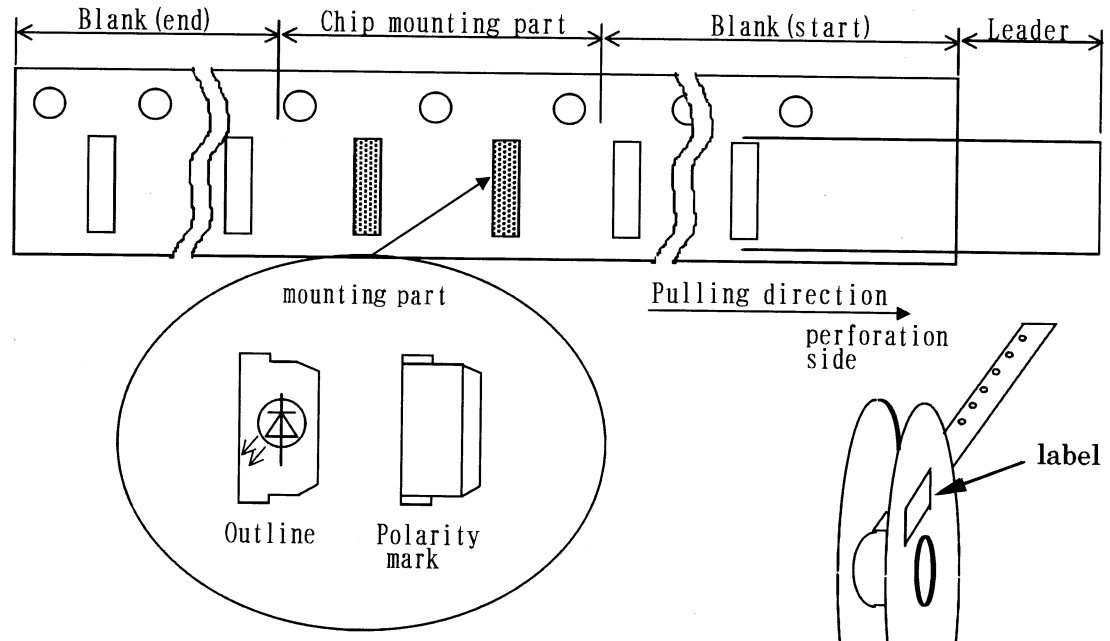

2-1 Feeding holes should be on the opposite side of the side where the label is stuck.

2-2 Chip LED taping direction.

Feeding holes' side is cathodic side.

The top of a Chip LED faces the cover tape.

2-3 Apply adhesive tape on the leader which should be 200 mm or longer.

2-4 Keep more than 10 emboss blanks at front and end of the taping.

Product name indication

Example      LNJO10X6F    RA

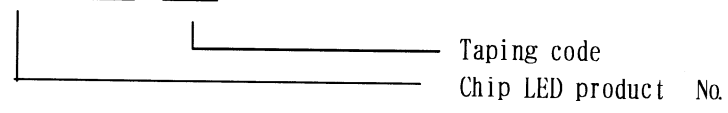

Oct. 2. 2002			

Approved	Checked	Designed	DEVELOPMENT SPECIFICATION				
<i>T. Sheda</i>	<i>M. W.</i>	<i>H. H. H.</i>	P/N: LNJ 010 X6 FRA				

~Taping Specifications~

3. Mechanical strength and treatment

3-1 Exfoliation strength of the cover tape should be 0.19~0.69 N.

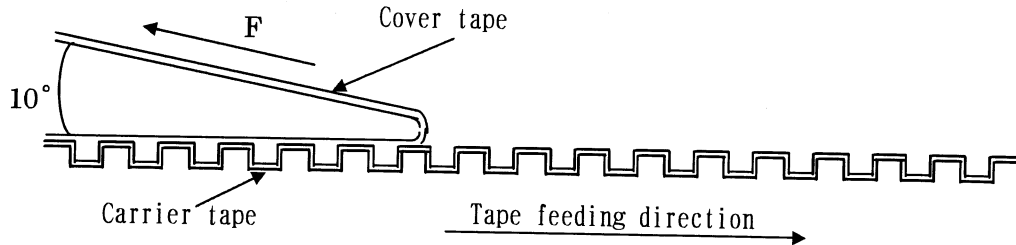

3-2 Tape bending strength

Tape should not be deformed by bending with a radius of 15 mm.

3-3 Removal of product

Chip LED should not be adhered to the cover tape.

3-4 Storing and leaving the tape aside

The tape should be stored under  $25 \pm 5^\circ \text{C}$  of temperature and under 70 % of humidity. Do not expose the tape to direct sunlight.

3-5 Defective percentage of enclosed

The product which was enclosed in reverse direction or with back side up Should be counted as 0 piece/reel.

The number of dropped parts should be 0.1 % of entire number of parts or 1 piece, whichever larger. There should be no continuous dropping however, total number has to remain intact.

3-6 There should be no tape joint.

Oct. 2. 2002	Feb. 17. 2003		

Approved	Checked	Designed	DEVELOPMENT SPECIFICATION			
<i>T. Akeda</i>	<i>M. Ichi</i>	<i>M. Nakayoshi</i>	P/N: LNJ010X6FRA			

~Packaging Specifications~

4. Packing unit and label position

4-1 A reel of 3,000 LED's is basic unit.

4-2 Both the reel and silica gel are contained in the Moisture barrier bag.

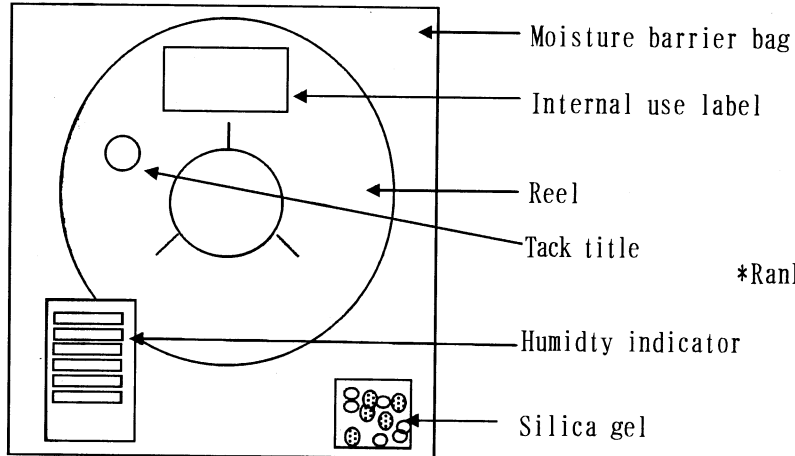

\*Rank can not be mixed within a reel.

4-3 Carton (inner)

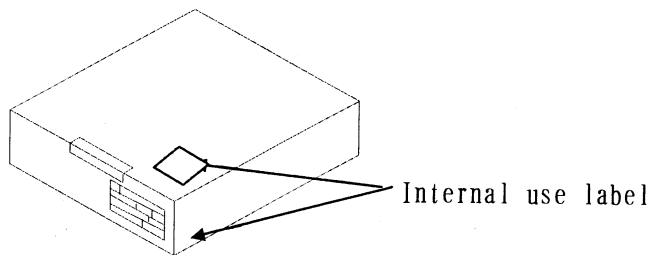

\*Rank can be mixed within a packing.

4-4 Inner carton unit (outer)

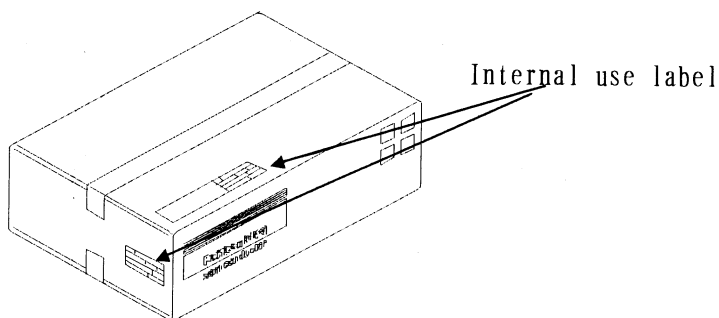

\*Rank can be mixed within a packing.

Oct. 2. 2002	Feb. 17. 2003		

Approved	Checked	Designed	DEVELOPMENT SPECIFICATION
<i>T. Shoda</i>	<i>M. Ichi</i>	<i>J. Horiguchi</i>	

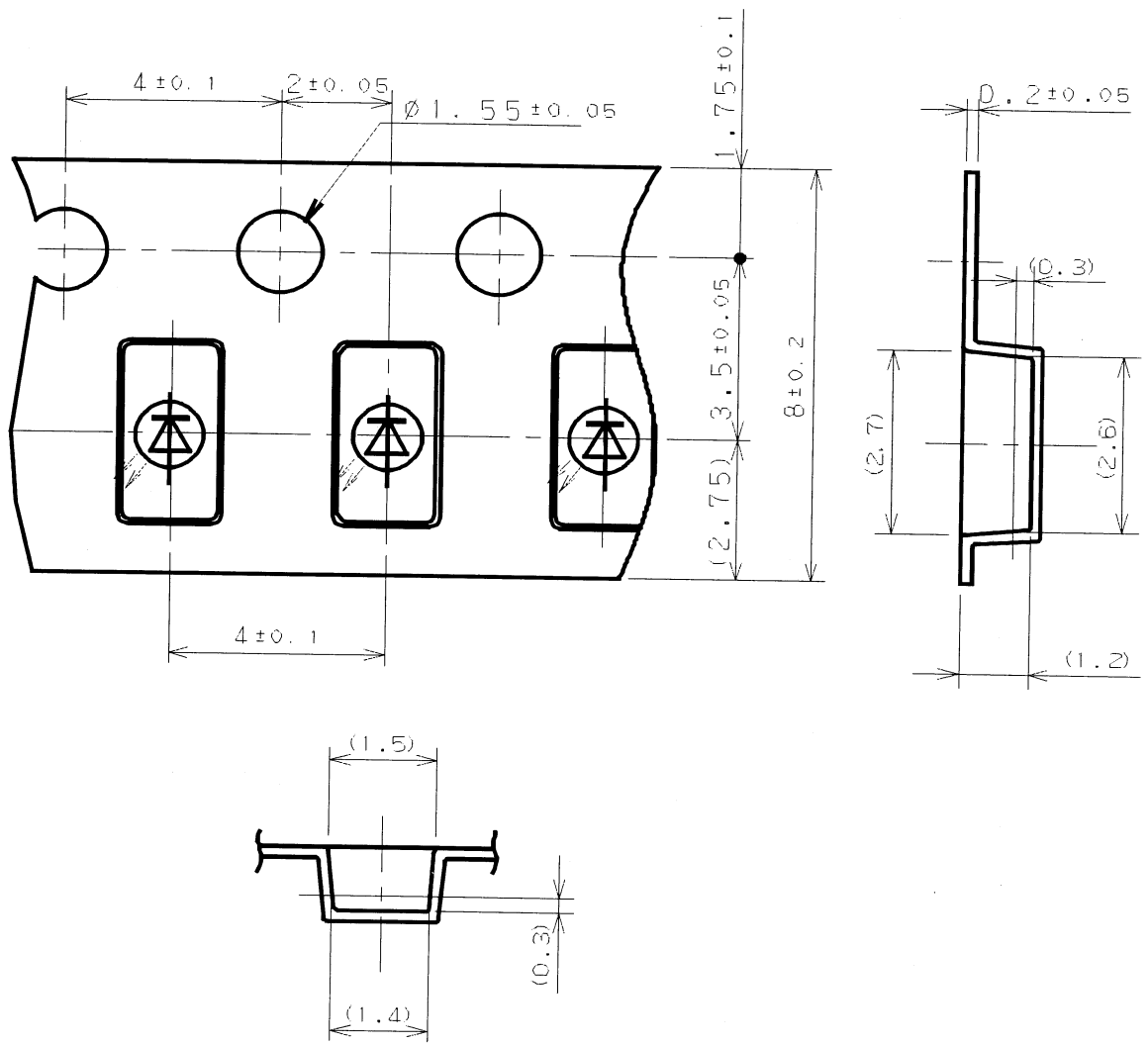

**NOTE**

- 1) Unless otherwise specified, R of the corner is max.0.3.
- 2) Allowance of accumulated pitch of feeding holes is  $\pm 0.2$  per 20 pitches.
- 3) Unit : mm

Oct. 2. 2002		

Panasonic

KAGOSHIMA MATSUSHITA ELECTRONICS CO., LTD

KB-H-022-018B

Approved	Checked	Designed	DEVELOPMENT SPECIFICATION			
<i>T. Akeda</i>	<i>M. Hiji</i>	<i>S. Higuchi</i>		P/N: LNJ010X6FRA		

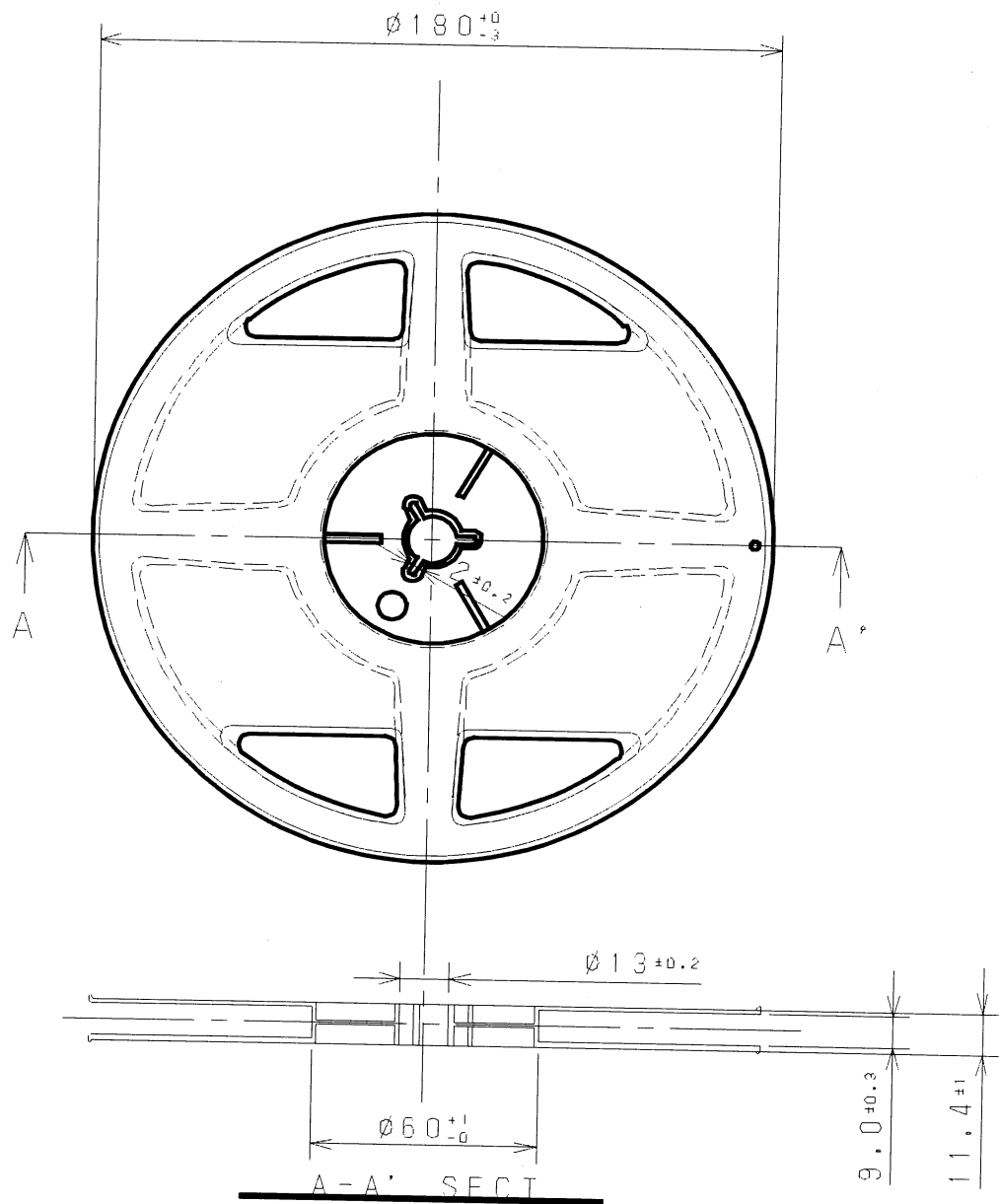

**NOTE**

- 1) This part is application of EIAJ ETX-7001.
- 2) Unit : mm

Oct. 2. 2002			

Panasonic

KAGOSHIMA MATSUSHITA ELECTRONICS CO., LTD

KB-H-022-018B

Approved	Checked	Designed	DEVELOPMENT SPECIFICATION			
<i>T. Akeda</i>	<i>M. Iwano</i>	<i>M. Haseguchi</i>	P/N: LNJ010X6FRA			

~ Internal use Label Items ~

1. Packing Division

- Reel : 3,000 pieces
- Packing (inner) : 9,000 pieces
- Packing (outer) : 18,000 pieces

2. Contents

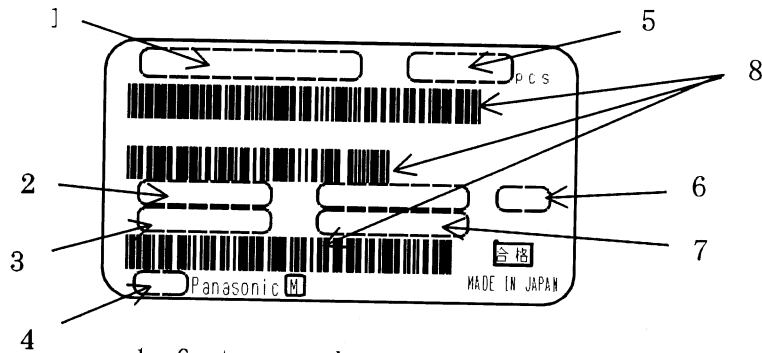

1. Customer code
2. Rank (Luminous Intensity/Chromaticity coordinates)
3. Date code
4. Date of label printing
5. Quantity
6. Warehouse control
7. Product number
8. Bar code symbol

• Example of date code

Date code of "20" indicates Oct. 2002 (Date of taping and case packing).

Oct. 2. 2002	Feb. 17. 2003		

Approved	Checked	Designed	DEVELOPMENT SPECIFICATION			
T. Akeda	M. W.	M. Higuchi	P/N: LNJ 010X6FRA			

~ Handling note ~

1. Storage

In order to avoid moisture absorption of the product under transportation and storage, prevention of moisture packing with a Moisture Barrier Bag is performed.

In this packing bag, the "Humidity indicator" which shows the level of moisture absorption is contained, and if moisture absorption progresses, it will become pink from blue.

According to the indication, please handle as follows.

Also, in order to keep dry condition in package, silica gel is enclosed in package.

Since prevention of moisture packing is carried out after opening should observe usable term strictly. When kept in the state of opening, please keep it in a dry box, or seal (silica gel is entered) on a tape.

\* Handling based on indications of Humidity indicator;

- ① No change color (Blue) → Good condition
- ② Changed at "20 %RH" → Please examine packaging or change desiccant (From light blue to pink)
- ③ Changed at "40 %RH" → Please use after baking (From blue to pink)

1-1. Storage limit of product

Storage term of the product is within one year.  
(Temp : 25±5 °C humidity : 70 % or less)

1-2. Usable term after unpacking

within 3 days (Temp : 25±5 °C humidity : 70 % or less)  
The product left unpacked may have its characteristics deteriorated.

1-3. Dehumidification baking

If the epoxy in the LED is exposed to humidity it can dehumidify by baking before soldering.

- 1) After placement and before soldering : 115 °C × 4~15 h (within twice)
- 2) In carrier (before placement) : 60 °C × 12~24 h (within once)

In case (2), you have to use without loading stress after you leave the products more than one hour.

2. Washing

If organic solvent such as trichlene(trichloroethylene) or acetone adheres to the surface, the condition of the surface may change.

As a rule do not wash with the organic solvent.

\* For supersonic washing, make sure the condition completely beforehand.

Oct. 2. 2002	Feb. 2003. 2. 17		

Approved	Checked	Designed	DEVELOPMENT SPECIFICATION				
<i>T. Ohashi</i>	<i>M. Ichi</i>	<i>T. Horiguchi</i>		P/N: <u>LNJ010X6FRA</u>			

~ Handling note ~

3. Flux to be used

Use isopropyl alcohol (JISK8839) solvent of rosin (JISK5902) or the equal.

4. Reflow soldering

4-1. The first time reflow soldering

As it is feared that using a products of leaving more than 3 days, please observe storage term and condition in this specification strictly and proceed the reflow soldering in the following conditions.

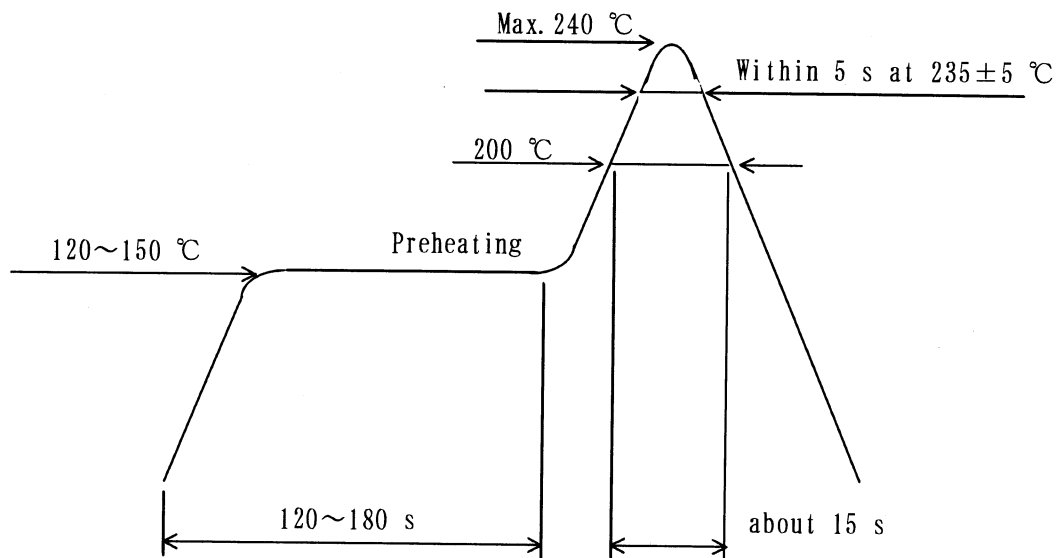

\*This should be a profile on the PC board and FPC surface.

4-2. The second time reflow soldering

In case of the second time reflow, please store the product under  $25 \pm 5$  °C, 70 %RH and proceed the reflow soldering in the same condition of 1st reflow within 3 days

4-3. Manual soldering

- Basically Keep the temperature on the edge of iron at 350 °C and apply for 3 s. If the temperature is higher, apply in a shorter time (1 sec per 10 °C)
- It is recommended a iron with a temperature control be used.
- When using manual soldering, take care not to damage the package.
- Especially do not let iron contact with lead or resin.

(Do not give stress when soldering.)

- In correction, do not re-use the product which was solderd and removed.

Oct. 2. 2002	Feb. 2003. 2. 17		



Approved	Checked	Designed	DEVELOPMENT SPECIFICATION			
<i>T. Okada</i>	<i>M. I.</i>	<i>J. Horiguchi</i>	P/N : LNJ 0 1 0 X 6 FRA			

~ Mounting specifications ~

1. Automatic placement

These products are available for automatic placement machines. However, demand on structure and performance of these devices, you should pay attentions as the following.

1-1. Though we've performed anti-static operation on these devices, static electricity may be occurred by dry atmosphere, and may cause to stick products on cover tapes. Please study to control humidity, and to perform anti-static measures.

1-2 If a successful placement is not secured on your systems, you may study the following subjects.

Inside diameter of tool	Especially for round shaped tool, please choose it not to stick Out the LED's lens area. (Example : 1005 type tool is suitable for 1608 LED's.)
Shape of tool	For a particular tool ("asterisk" type etc.), please study a location and size of tool not to incline parts, in placing.
Height of tool	Please adjust a height of tool as minus from top of the face of tape guide.
Position in absorption	Please adjust a absorb position as a center of device as possible.
Vibration in placing	Please maintain your machines to successful placement, like as adjusting placing speed, tensions in winding and feeding tapes.
Pin push up system	"Pin push up system" is suitable only for products prepared pin-hole (by $\phi 0.5$ mm) on bottom of embossed tape, but not for others.

2. Strength of products

In these products, we use epoxy resin for molding LED devices. The resin is softened by heating, and strength of resin becomes weak, different from that of other SMD's. So you should keep products from shocking on resin side, especially in reflow Soldering process and using by soldering irons.

And after soldering process, please avoid shocking directly on resin side, such as in the following cases, handling PCB's, piling them up, and putting them in magazines.

Oct. 2. 2002			

Approved	Checked	Designed	DEVELOPMENT SPECIFICATION			
<i>T. I. Honda</i>	<i>M. W.</i>	<i>Y. H. Hasegawa</i>	<u>P/N: LN J 0 1 0 X 6 F R A</u>			

Request for your special attention and precautions in using the technical information and semiconductors described in this book

1. An export permit needs to be obtained from the competent authorities of the Japanese Government if any of the products or technologies described in this book and controlled under the "Foreign Exchange and Foreign Trade Law" is to be exported or taken out of Japan.
  2. The technical information described in this book is limited to showing representative characteristics and applied circuits examples of the products. It neither warrants non-infringement of intellectual property right or any other rights owned by our company or a third party, nor grants any license.
  3. We are not liable for the infringement of rights owned by a third party arising out of the use of the product or technologies as described in this book.
  4. The products described in this book are intended to be used for standard applications or general electronic equipment (such as office equipment, communications equipment, measuring instruments and household appliances). Consult our sales staff in advance for information on the following applications:
    - Special applications (such as for airplanes, aerospace, automobiles, traffic control equipment, combustion equipment, life support systems and safety devices) in which exceptional quality and reliability are required, or if the failure or malfunction of the products may directly jeopardize life or harm the human body.
    - Any applications other than the standard applications intended.
  5. The products and product specifications described in this book are subject to change without notice for modification and/or improvement. At the final stage of your design, purchasing, or use of the products, therefore, ask for the most up-to-date Product Standards in advance to make sure that the latest specifications satisfy your requirements.
  6. When designing your equipment, comply with the guaranteed values, in particular those of maximum rating, the range of operating power supply voltage, and heat radiation characteristics. Otherwise, we will not be liable for any defect which may arise later in your equipment.
- Even when the products are used within the guaranteed values, take into the consideration of incidence of break down and failure mode, possible to occur to semiconductor products. Measures on the systems such as redundant design, arresting the spread of fire or preventing glitch are recommended in order to prevent physical injury, fire, social damages, for example, by using the products.

Oct. 2. 2002	Feb. 17. 2003		

Panasonic

KAGOSHIMA MATSUSHITA ELECTRONICS CO., LTD.

KB-H-022-018B

Approved	Checked	Designed	DEVELOPMENT SPECIFICATION				
<i>T. Shoda</i>	<i>M. I.</i>	<i>M. Hagiwara</i>		P/N: LNJ010X6FRA			

RELIABILITY TEST DATA

TEST ITEM	TEST CONDITION	RESULTS
Consecutive operating life test	$I_F=30$ mA DC, $T_a=25$ °C, $t=500$ h	0/20
High temperature Storage life test	Tstg max., $t=500$ h	0/20
Low temperature Storage life test	Tstg min., $t=500$ h	0/20
Temperature humidity storage life test	$T_a=65$ °C, $RH \geq 95$ %, $t=500$ h	0/20
Intermittent operating life test	$I_F=30$ mA DC, $T_a=25$ °C, Time : (on: 15sec off: 15sec) × 10,000 cycles	0/20
Soldering heat test	Temperature : $T_a=235 \pm 5$ °C, $t=5$ s max., Max. 240 (Reflow soldering)	0/20
Temperature cycle test (gaseous phase)	Temperature : [Tstg min. ~ 25 °C ~ Tstg max. ~ 25 °C] Time : (30 min 5 min 30 min 5 min) × 5 cycles	0/20
Thermal shock resistance test (liquid phase)	Temperature : [Tstg max. ~ Tstg min.] Time : (5 min 5 min) × 5 cycles	0/20
Fall test	Maple Wood $h=75$ cm, 3 times	0/20

Fault judgment criteria

ITEM	SYMBOL	CONDITIONS	LIMIT	UNIT
Forward Voltage	$V_F$	Same as the specification	Upper × 1.2	V
Luminous Intensity	$I_o$	Same as the specification	★ Min. × 0.7	mcd

★The decreasing ratio of luminous intensity after the operating test should be greater than 50% of Initial intensity

Assurance

- This is only reference value, not guarantee value.
- If you demand some particular content, please inquire for us.

Feb. 17. 2003			

单击下面可查看定价，库存，交付和生命周期等信息

[>>Panasonic\(松下\)](#)