

Approved	Checked	Designed	DEVELOPMENT SPECIFICATION	TEMPORARY
		T. Tabata		

T Y P E	Green Light Emitting Diode					
APPLICATION	Indicators					
MATERIAL	GaP					
OUTLINE	Attached					
ABSOLUTE MAXIMUM RATINGS	P	*1 I <sub>FP</sub>	I <sub>FDC</sub>	V <sub>R</sub>	Topr	Tstg
	60	60	20	4	-30~+85	-40~+100
	mW	mA	mA	V	°C	°C
CONDITION	T <sub>a</sub> = 25 ± 3°C					

Test Specification

I t e m	Symbol	C o n d i t i o n	Typ	Limit		Unit
				Min	Max	
Forward Voltage	V <sub>F</sub>	I <sub>F</sub> = 10 mA	2.03		2.6	V
Reverse Leakage Current	I <sub>R</sub>	V <sub>R</sub> = 4 V			10	μA
Luminous Intensity *2	I <sub>O</sub>	I <sub>F</sub> = 10 mA DC	3.5	2.0		mcd
Peak Emission Wavelength	λ <sub>p</sub>	I <sub>F</sub> = 10 mA DC	555			nm
Spectral Line Half Width	Δλ	I <sub>F</sub> = 10 mA DC	20			nm

- \*1. The Condition of I<sub>FP</sub> is duty 10 %, Pulse width 1 ms
- \*2. Tolerance of luminous intensity : ±20%.

NOTE

- ★1. Please contact the Panasonic local office if you design at low current (below 1mA DC) or pulse current operation and have any questions.
- ★2. Soldering conditions...Refer to Handling note.
- ★3. Compositions of the lead ... Cu/Ni/Au plating
- ★4. Circuit to operate LED.

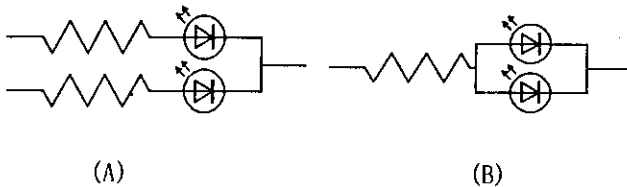

- (A) Recommended circuit.
- (B) The difference of brightness between the LED could be found due to the V<sub>F</sub> characteristics of each LED.

Nov. 7. 2001			

Approved	Checked	Designed
		T. Takata

DEVELOPMENT SPECIFICATION

P/N: LNJ318C8PRA

TEMPORARY

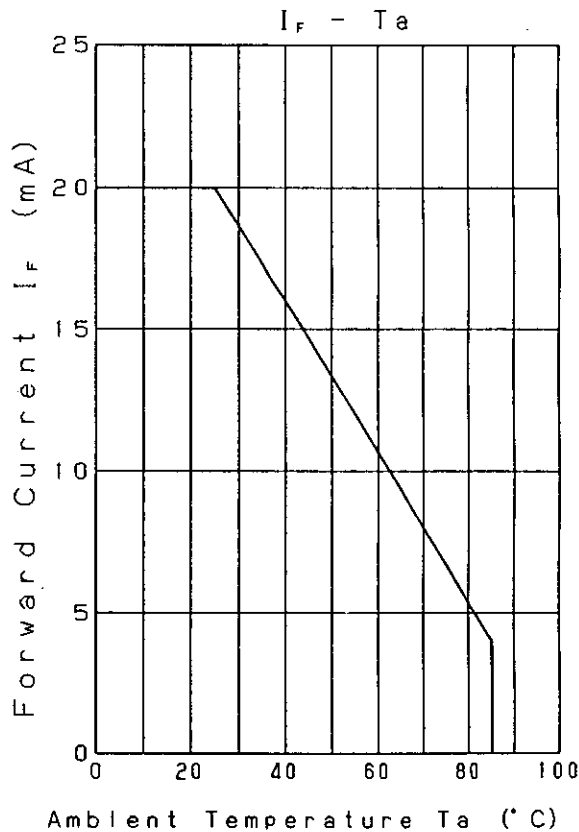
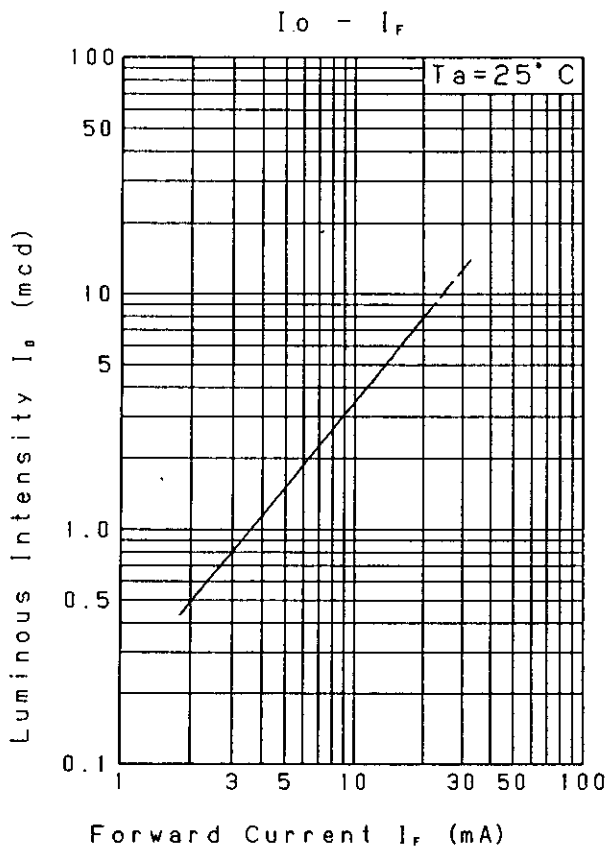
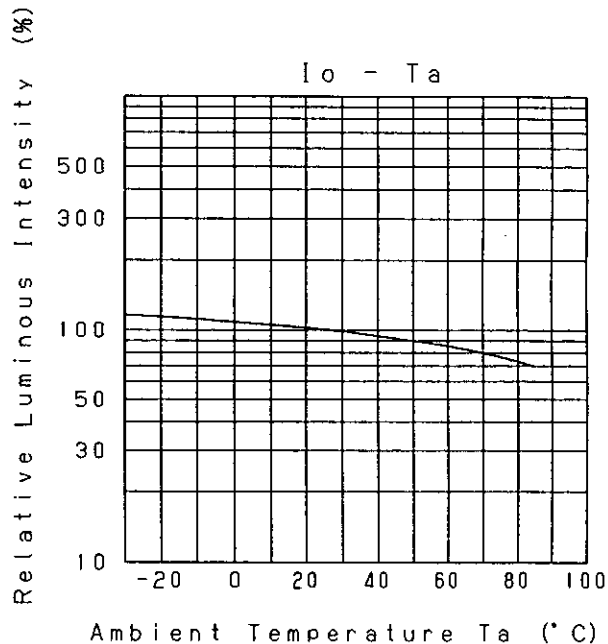
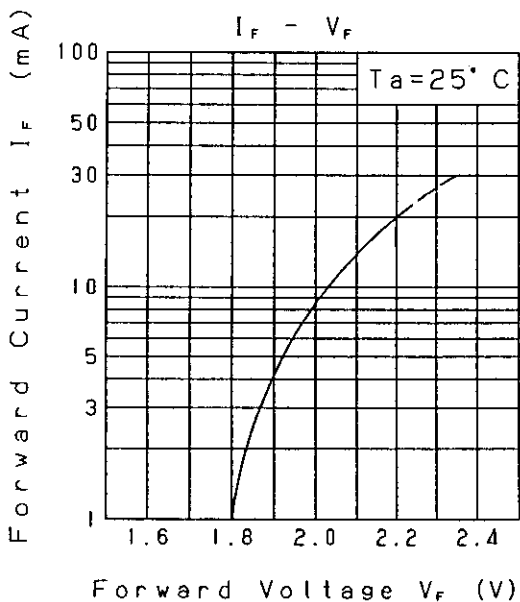

Nov. 7. 2001

Approved	Checked	Designed
		T. Tabata

DEVELOPMENT SPECIFICATION

P/N: LNJ318C8PRA

TEMPORARY

Relative Luminous Intensity  
Wavelength Characteristics

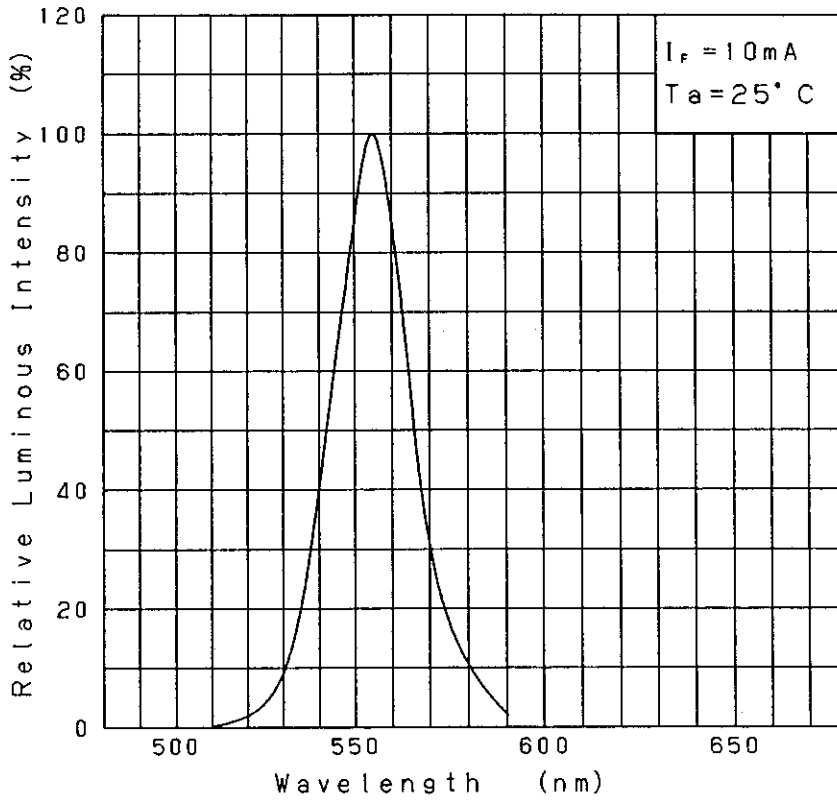

Directive Characteristics

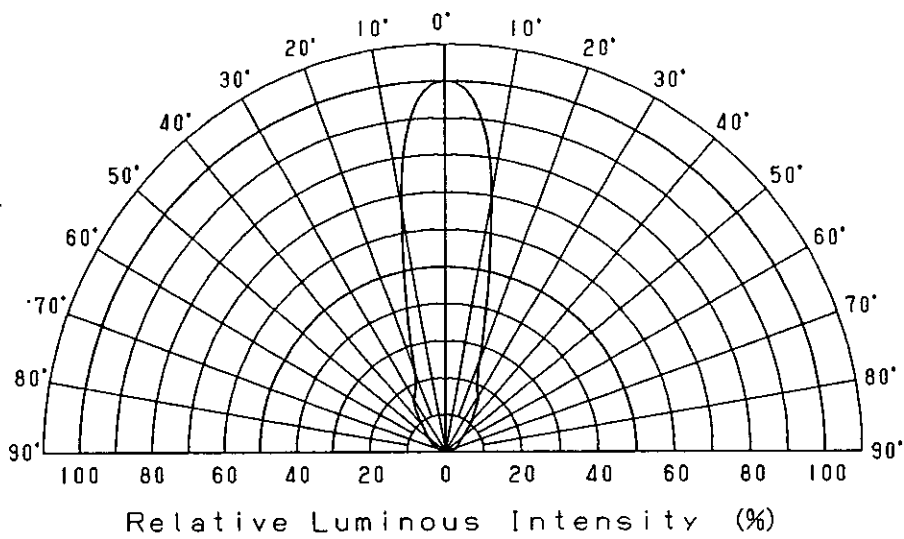

Nov. 7. 2001

Approved    Checked    Designed

T. Shudo    h. h.    T. Tabata

# DEVELOPMENT SPECIFICATION (OUTLINE)

P/N: \_\_\_\_\_

TEMPORARY

Outline

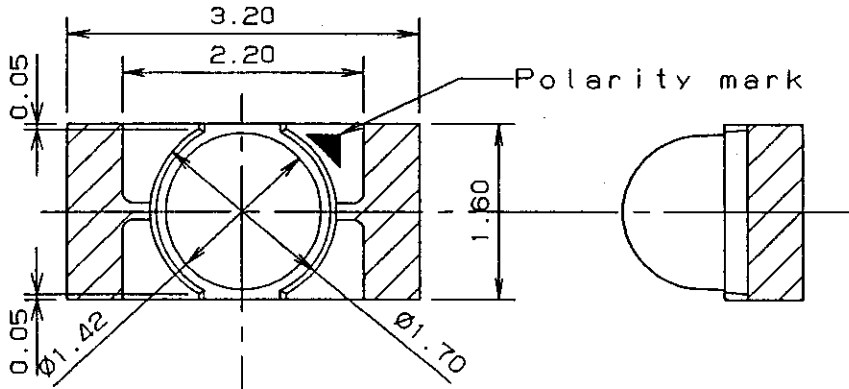

Protect mask

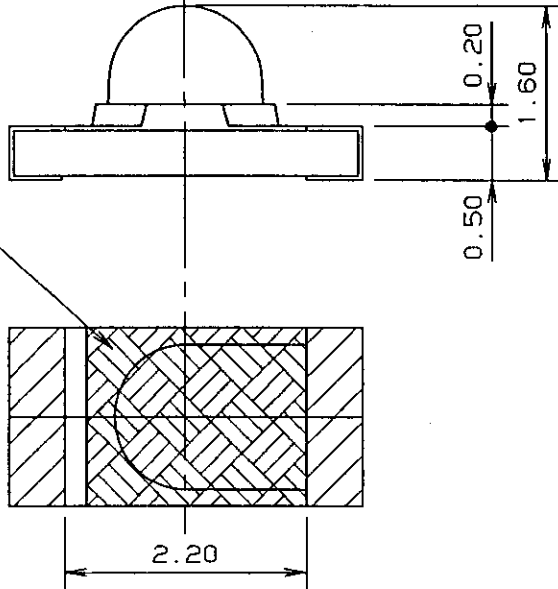

Recommended Land Layout

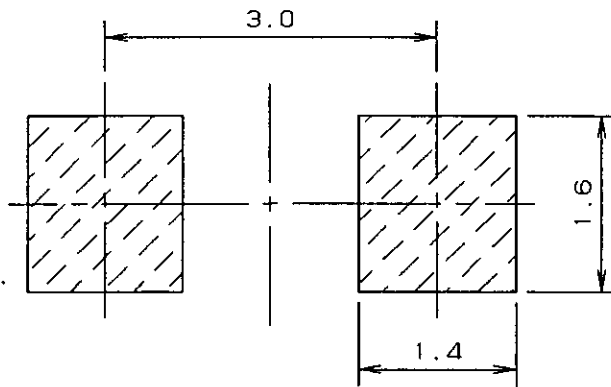

Polarity

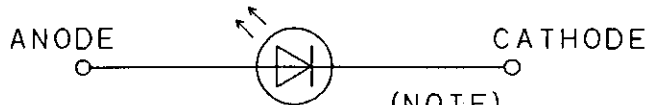

(NOTE)

1. Unit: mm

2. Tolerance unless specified is  $\pm 0.15$ .

3. indicate Au terminal.

Jul. 5.2001

Panasonic

KAGOSHIMA MATSUSHITA ELECTRONICS CO., LTD.

KB-H-022-018B

单击下面可查看定价，库存，交付和生命周期等信息

[>>Panasonic\(松下\)](#)