

Approved	Checked	Designed	DEVELOPMENT SPECIFICATION	TEMPORARY		
		<i>T. Takata</i>				

T Y P E	Amber Light Emitting Diode					
A P P L I C A T I O N	Indicators					
M A T E R I A L	InGaAlP					
O U T L I N E	Attached					
A B S O L U T E M A X I M U M R A T I N G S	P	*I <sub>FP</sub>	I <sub>FDC</sub>	V <sub>R</sub>	Topr	Tstg
	55	60	20	4	-30~+85	-40~+100
	mW	mA	mA	V	°C	°C
C O N D I T I O N	T <sub>a</sub> = 25 ± 3°C					

Test Specification

I t e m	Symbol	C o n d i t i o n	Typ	Limit		Unit
				Min	Max	
Forward Voltage	V <sub>F</sub>	I <sub>F</sub> = 10 mA	2.0		2.5	V
Reverse Leakage Current	I <sub>R</sub>	V <sub>R</sub> = 4 V			100	μA
Luminous Intensity	I <sub>O</sub>	I <sub>F</sub> = 10 mA DC	85	45		mcd
Peak Emission Wavelength	λ <sub>p</sub>	I <sub>F</sub> = 10 mA DC	595			nm
Spectral Line Half Width	Δλ	I <sub>F</sub> = 10 mA DC	15			nm

- \*1. The Condition of I<sub>FP</sub> is duty 10%, Pulse width 1 ms
- \*2. Tolerance of luminous intensity: ±20%.

NOTE

- ★1. Please contact the Panasonic local office if you design at low current (below 1mA DC) or pulse-current operation and have any questions.
- ★2. Soldering conditions... Refer to Handling note.
- ★3. Compositions of the lead ... Cu/Ni/Au plating
- ★4. Beware of destruction by static electricity in handling the LED.
- ★5. Circuit to operate LED.

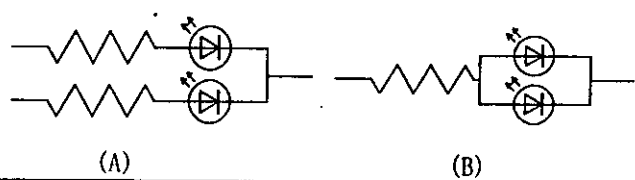

(A) Recommended circuit.  
 (B) The difference of brightness between the LED could be found due to the V<sub>F</sub> characteristics of each LED.

Nov. 7. 2001			
--------------	--	--	--

Approved	Checked	Designed	DEVELOPMENT SPECIFICATION	TEMPORARY
		T. Takahashi		

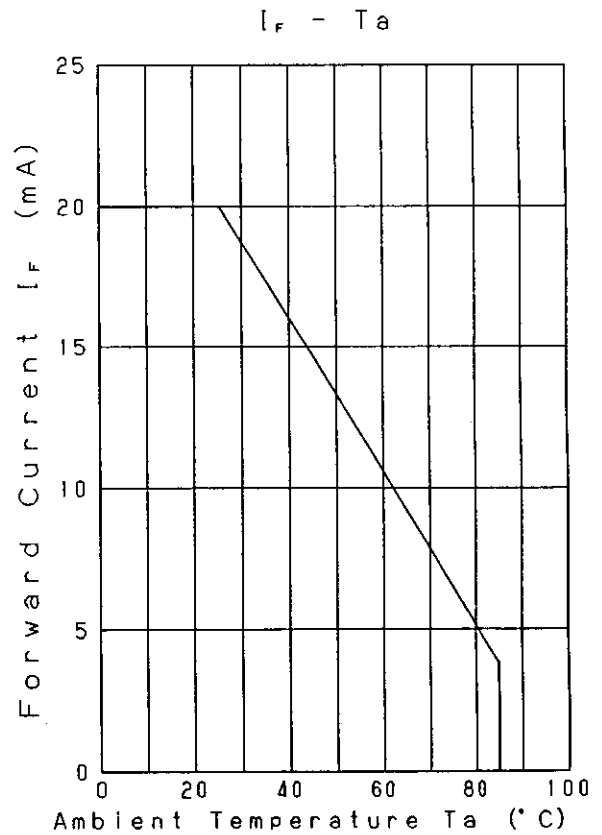
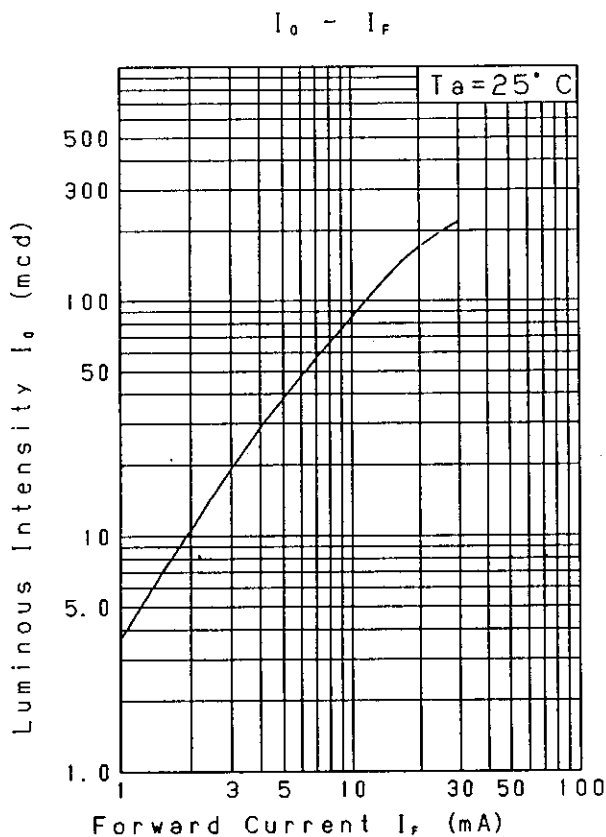
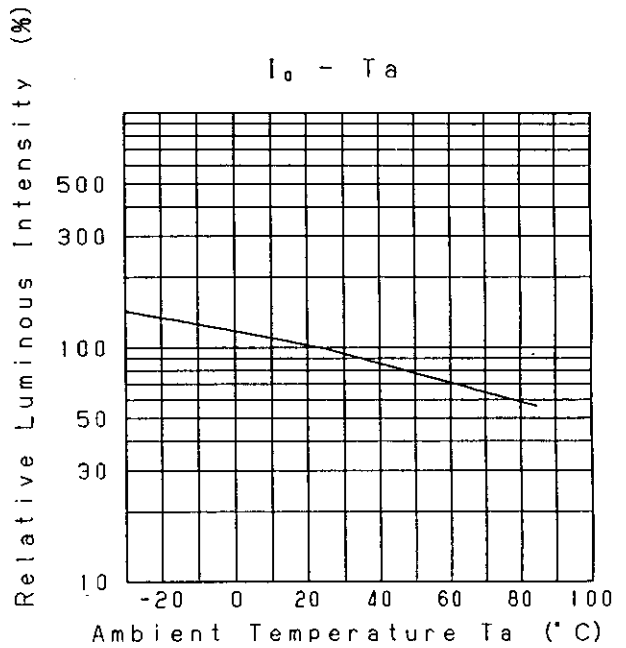
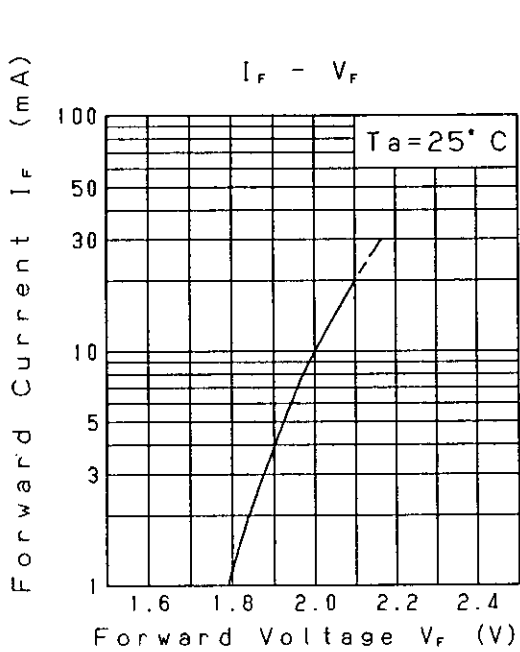

Nov. 7. 2001			
--------------	--	--	--

Approved	Checked	Designed	DEVELOPMENT SPECIFICATION	TEMPORARY
		T. Takata		

Relative Luminous Intensity  
Wavelength Characteristics

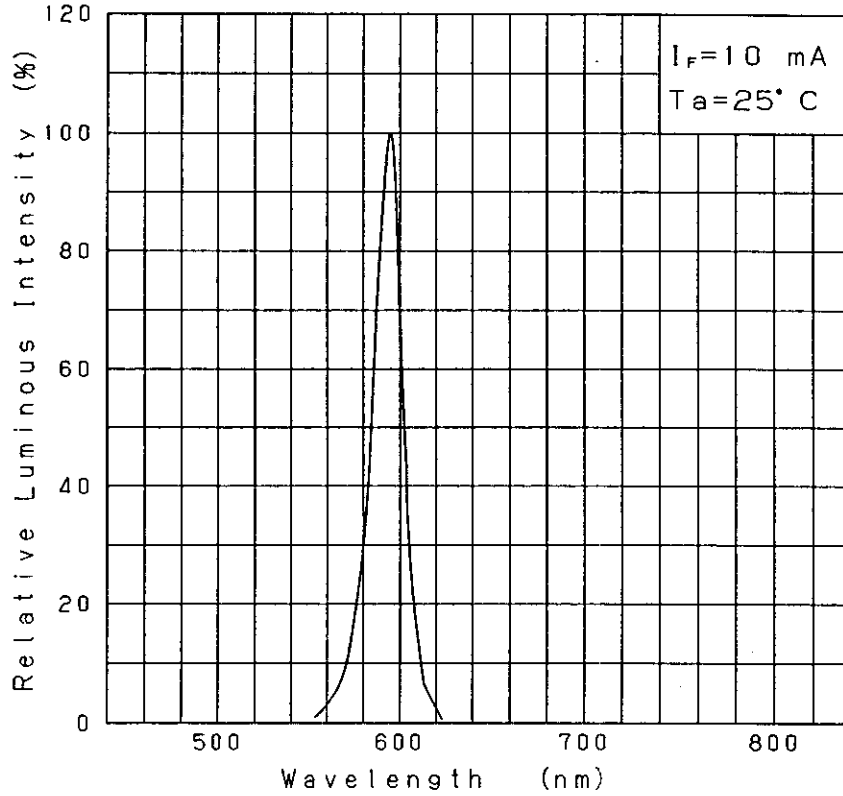

Directive Characteristics

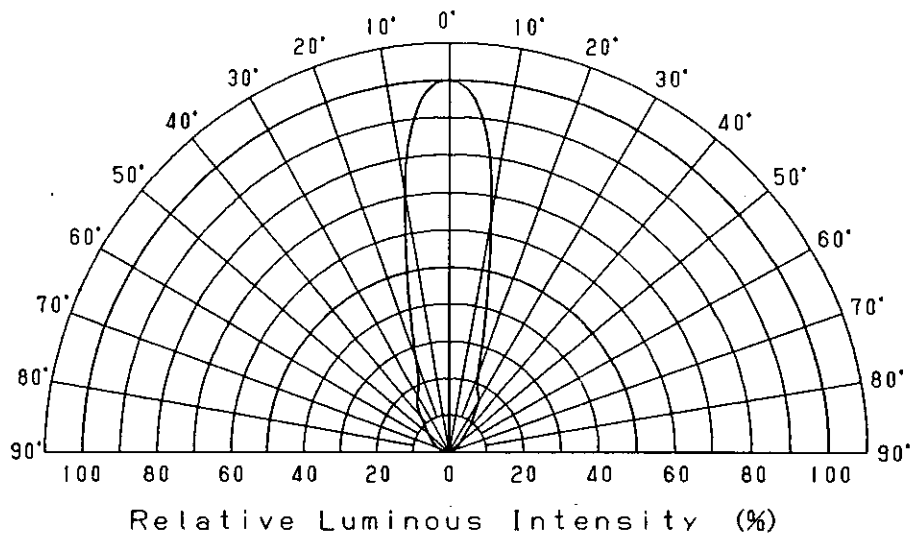

Nov. 7. 2001

Approved <i>T. Shudo</i>	Checked <i>h. h.</i>	Designed <i>T. Tabata</i>
-----------------------------	-------------------------	------------------------------

DEVELOPMENT SPECIFICATION  
(OUTLINE)

P/N: \_\_\_\_\_

TEMPORARY

Outline

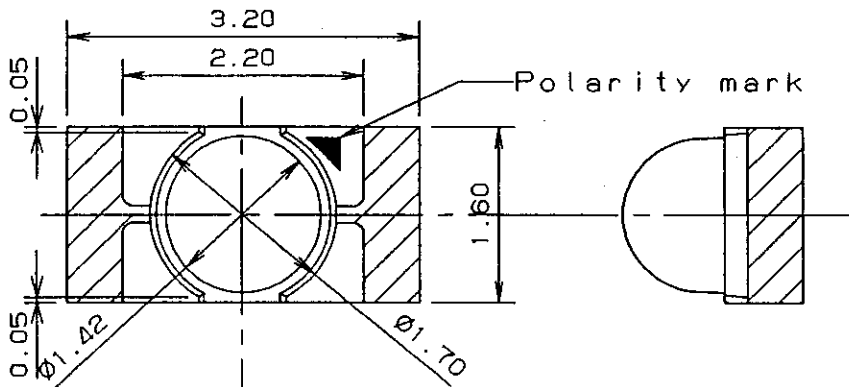

Protect mask

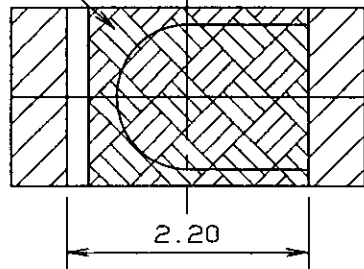

Recommended Land Layout

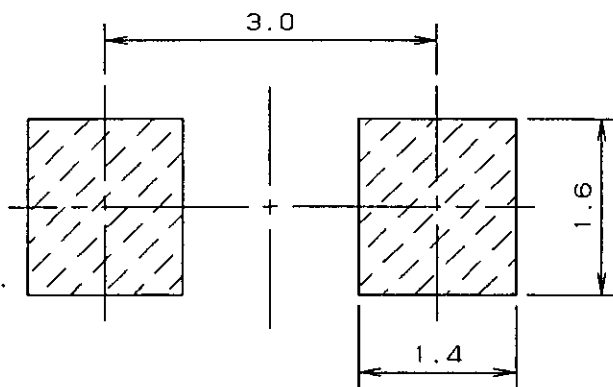

Polarity

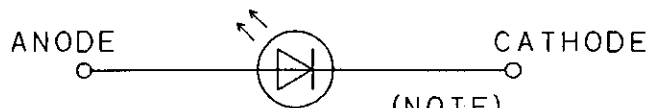

(NOTE)

1. Unit:mm
2. Tolerance unless specified is  $\pm 0.15$ .
3. indicate Au terminal.

Jul. 5.2001

Panasonic

KAGOSHIMA MATSUSHITA ELECTRONICS CO., LTD.

KB-H-022-018B

单击下面可查看定价，库存，交付和生命周期等信息

[>>Panasonic\(松下\)](#)