

Approved	Checked	Designed	DEVELOPMENT SPECIFICATION					
		T. Taketa	P/N: LNJ811R83RA				TEMPORARY	
T	Y	P	E	Orange Light Emitting Diode				
APPLICATION			Indicators					
MATERIAL			InGaAlP					
OUTLINE			Attached					
ABSOLUTE		P	*1 I <sub>FP</sub>	I <sub>FDC</sub>	V <sub>R</sub>	Topr	Tstg	
MAXIMUM		55	60	20	4	-30~+85	-40~+100	
RATINGS		mW	mA	mA	V	°C	°C	
CONDITION			T <sub>a</sub> = 25 ± 3°C					
Test Specification								
I t e m	Symbol	C o n d i t i o n	Typ	Limit		Unit		
				Min	Max			
Forward Voltage	V <sub>F</sub>	I <sub>F</sub> = 10 mA	2.03		2.5	V		
Reverse Leakage Current	I <sub>R</sub>	V <sub>R</sub> = 4 V			100	μ A		
Luminous Intensity *2	I <sub>O</sub>	I <sub>F</sub> = 10 mA DC	32	17		mcd		
Peak Emission Wavelength	λ <sub>p</sub>	I <sub>F</sub> = 10 mA DC	630			nm		
Spectral Line Half Width	Δλ	I <sub>F</sub> = 10 mA DC	15			nm		
<p>*1. The Condition of I<sub>FP</sub> is duty 10 % , Pulse width 1 ms</p> <p>*2. Tolerance of luminous intensity: ±20%.</p> <p>NOTE</p> <p>★1. Please contact the Panasonic local office if you design at low current (blow 1mA DC) or pulse current operation and have any questions.</p> <p>★2. Soldering conditions····Refer to Handling note.</p> <p>★3. Compositions of the lead ···· Cu/Ni/Au plating</p> <p>★4. Beware of destruction by static electricity in handling the LED.</p> <p>★5. Circuit to operate LED.</p>								
						(A) Recommended circuit.		
						(B) The difference of brightness between the LED could be found due to the V <sub>F</sub> characteristics of each LED.		
Oct. 18, 2001								

Approved	Checked	Designed	DEVELOPMENT SPECIFICATION	TEMPORARY
		T. Takata		

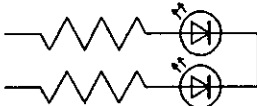
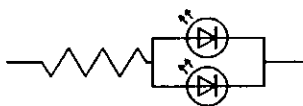
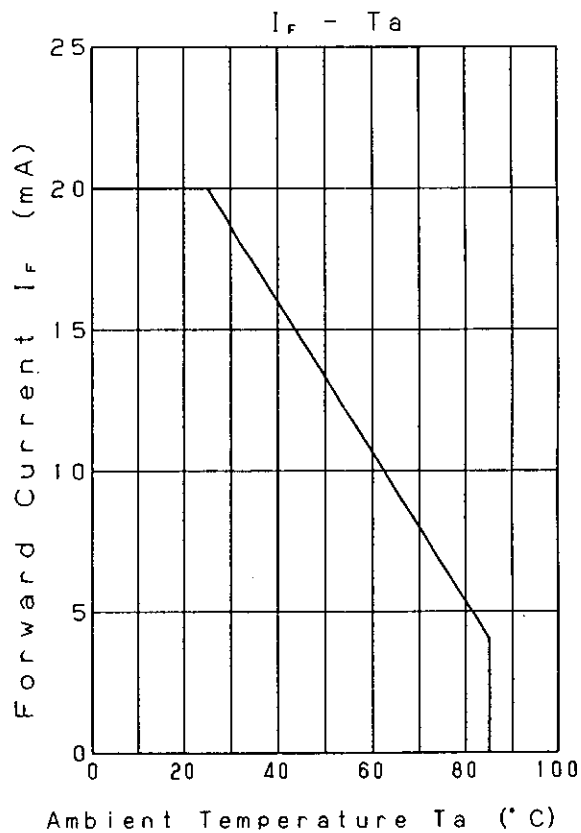
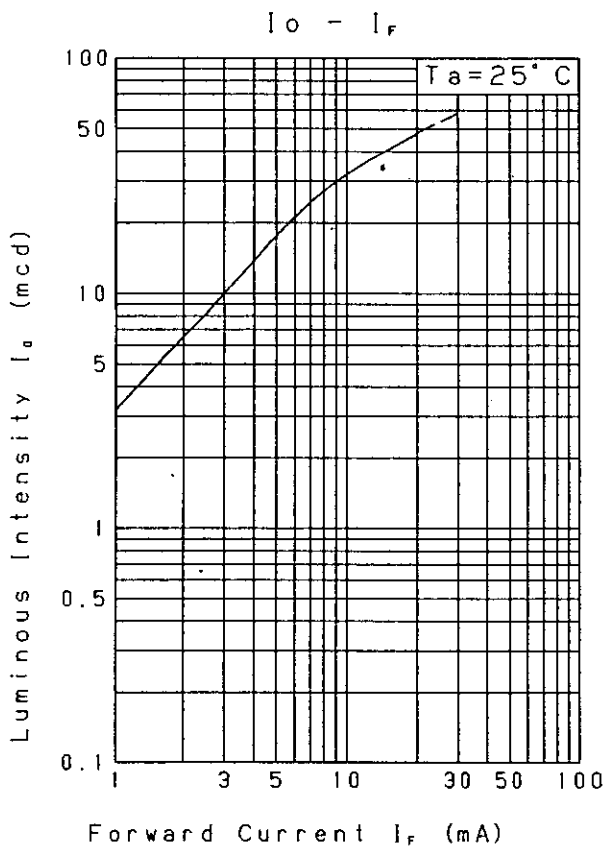
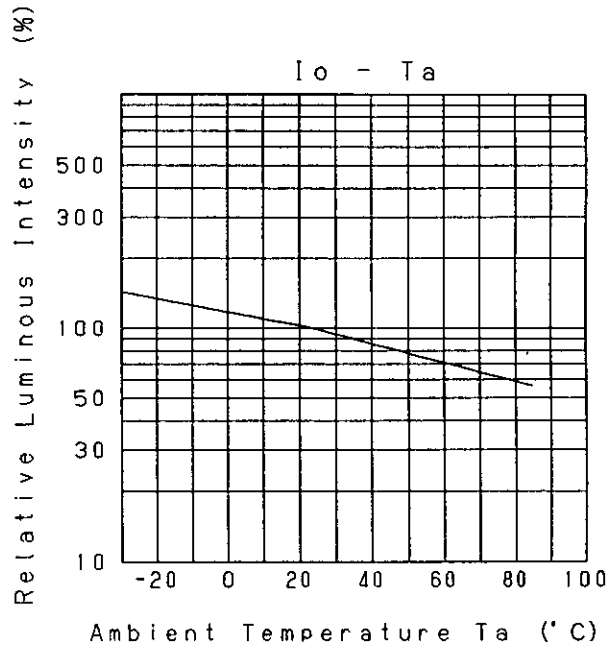
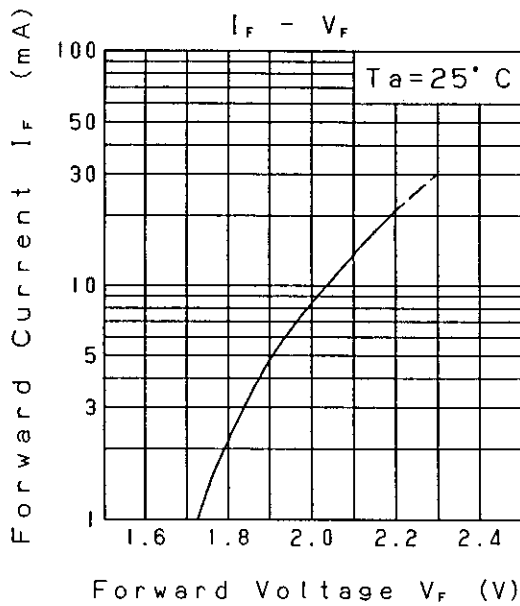

Oct.18.2001			
-------------	--	--	--

Approved	Checked	Designed
		T. Takata

DEVELOPMENT SPECIFICATION

P/N: LNJ811R83RA

TEMPORARY

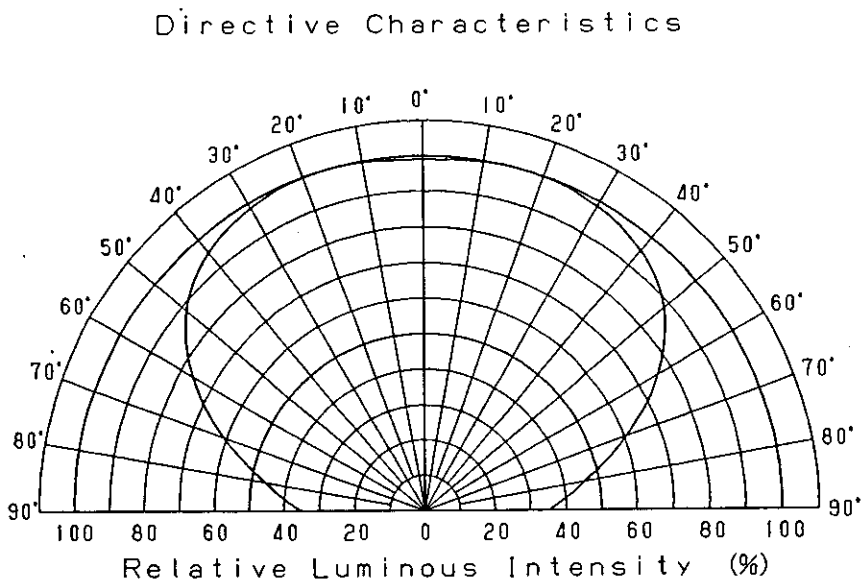
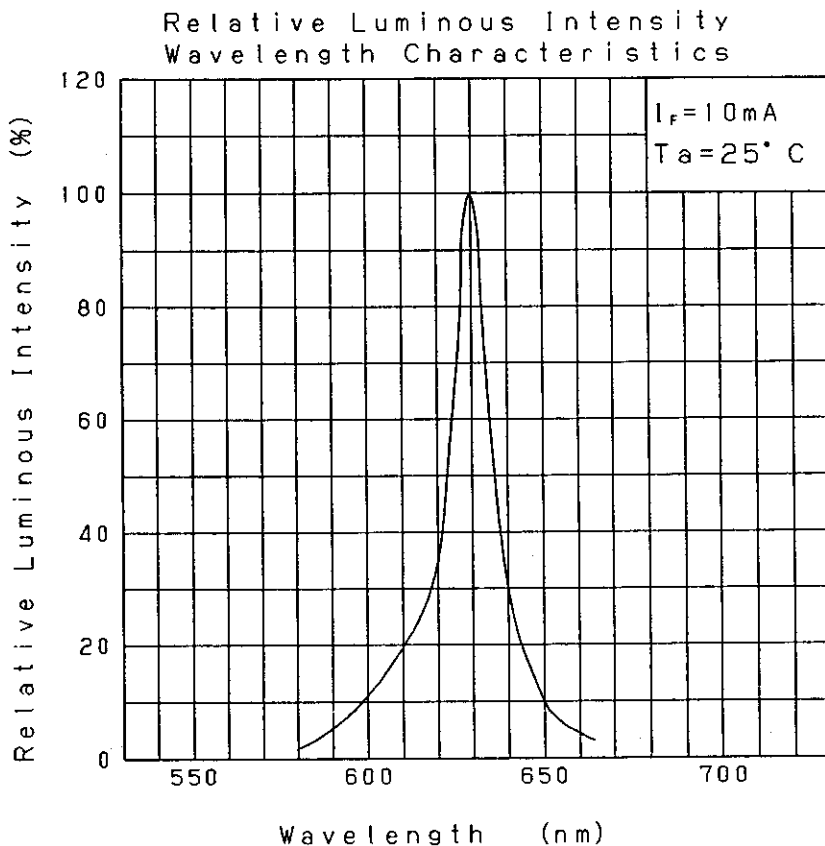

Oct. 18. 2001

Approved	Checked	Designed	DEVELOPMENT SPECIFICATION (OUTLINE)		
<i>H. Yama</i>	<i>T. Shiba</i>	<i>T. Tabata</i>		P/N: _____	

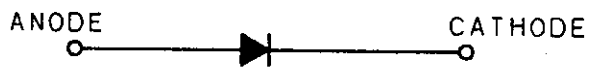
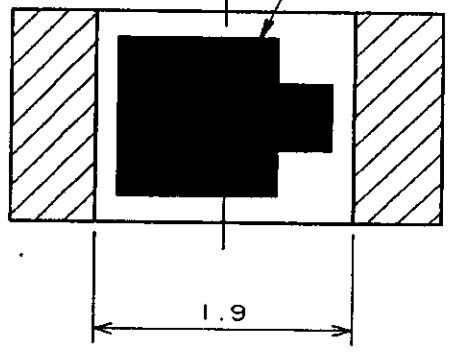
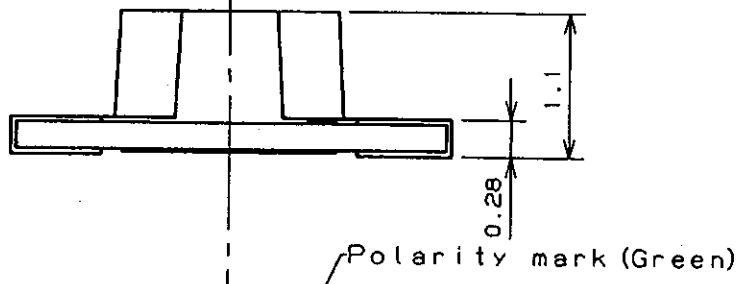
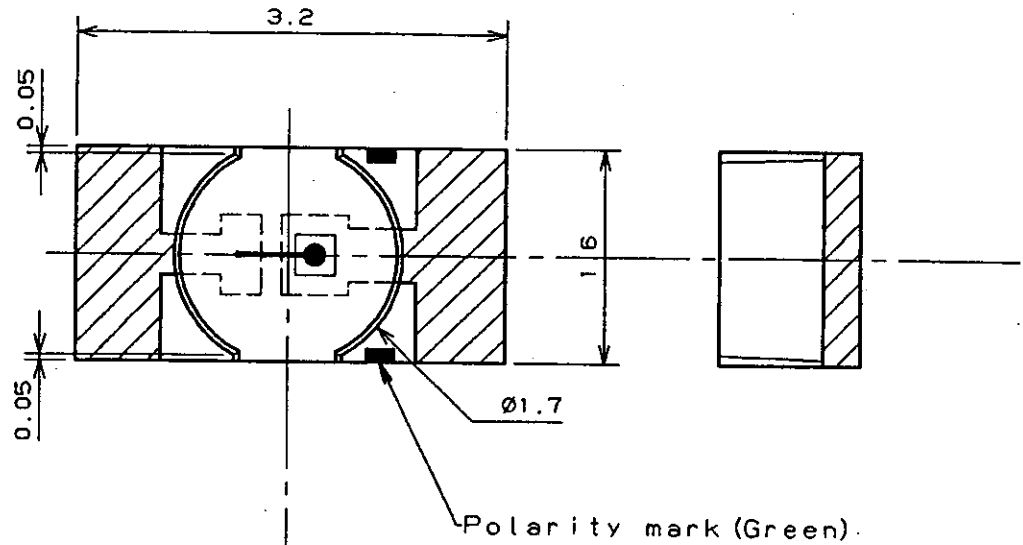

(NOTE)  
 1. Unit: mm  
 2. Tolerance unless specified is  $\pm 0.15$ .  
 3. indicate Au terminal.

Jan. 14, 1989			
---------------	--	--	--

单击下面可查看定价，库存，交付和生命周期等信息

[>>Panasonic\(松下\)](#)