

Approved	Checked	Designed	DEVELOPMENT SPECIFICATION							
T. Shoda	M. Imai	T. Tabata	P/N: LN J 9 1 1 W 8 B R A							
T	Y	P	E	Blue Light Emitting Diode						
APPLICATION				Indicators						
MATERIAL				GaN						
OUTLINE				Attached						
ABSOLUTE		P	*1 I _{FP}	I _{FDC}	V _R	Topr	Tstg			
MAXIMUM		40	50	10	5	-25~+85	-30~+100			
RATINGS		mW	mA	mA	V	°C	°C			
CONDITION				T _a = 25 ± 3 °C						
Test Specification										
Item	Symbol	Condition	Typ	Limit		Unit				
				Min	Max					
Forward Voltage	V _F	I _F = 5 mA	3.2		3.7	V				
Reverse Leakage Current	I _R	V _R = 5 V			10	μA				
Luminous Intensity *2	I _O	I _F = 5 mA DC	8.5	4.5		mcd				
Peak Emission Wavelength	λ _p	I _F = 5 mA DC	470			nm				
Spectral Line Half Width	Δλ	I _F = 5 mA DC	30			nm				
<p>*1: The Condition of pulse current I_{FP} is 1ms pulse width, 10 % duty cycle.</p> <p>*2: Tolerance of luminous intensity ±20%.</p> <p>· Please contact the Panasonic local office if you design at low current (below 1 mA DC) or pulse current operation and have any questions.</p>										
NOTE										
★1. Soldering conditions. Refer to Handling note.										
★2. Care should be taken that soldering is done within 3-days after opening the dry package and reel.										
★3. Compositions of the lead Cu/Ni/Au plating										
★4. This LED is sensitive to static electricity and care should be fully taken in handling it. Particularly, when an overvoltage is applied, which exceeds the absolute maximum rating of the LED, its energy damages the LED. Therefore, take utmost proactive measures against static electricity and surge as to building an assembly line and handling the LED halfway the process.										
(1) Check the entire drive circuit including the power source. For example, a surge current, etc., generated at power-on/off must not exceed the absolute maximum rating of the LED. Also, insert an appropriate protective circuit into the LED drive circuit.										
(2) Beware of destruction by static electricity in handling the LED. As proactive measures against static electricity, it is effective to earth your body (via 1MΩ), spread conductive mat on the floor, wear semiconductive work uniform and shoes, and use semiconductive containers. Also, be sure to earth the nose of a soldering iron. It is recommended to use an ionizer, etc., in the facility or environment where static electricity may be generated easily.										
Sep. 1. 1999										

Approved <i>T. Okada</i>	Checked <i>M. Niimi</i>	Designed <i>T. Takata</i>	DEVELOPMENT SPECIFICATION			
				P/N: <u>LNJ911W8BRA</u>		

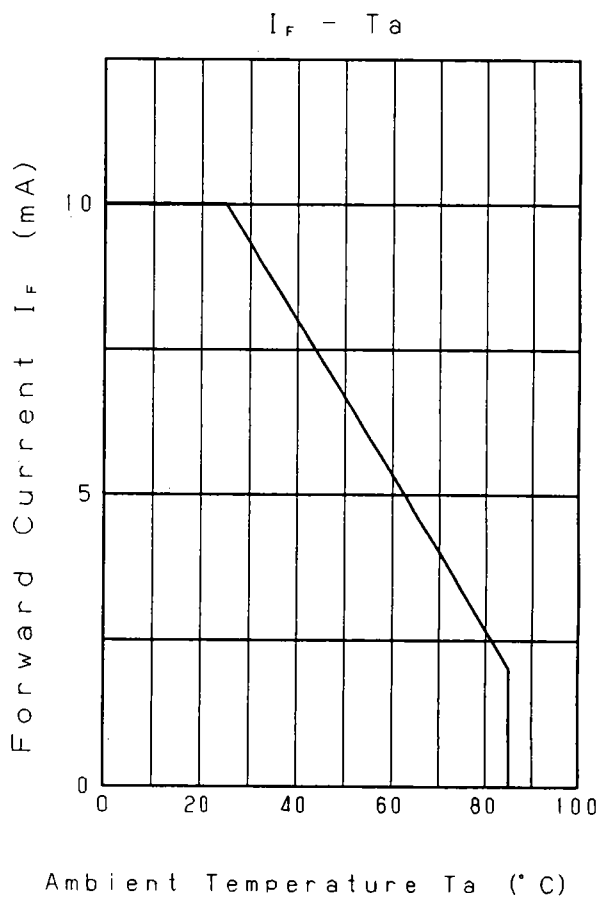
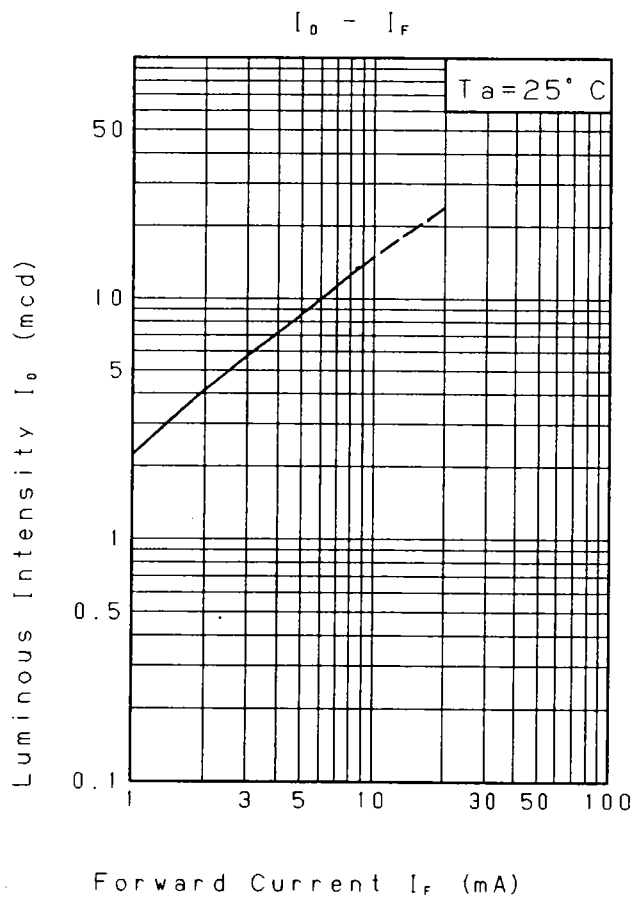
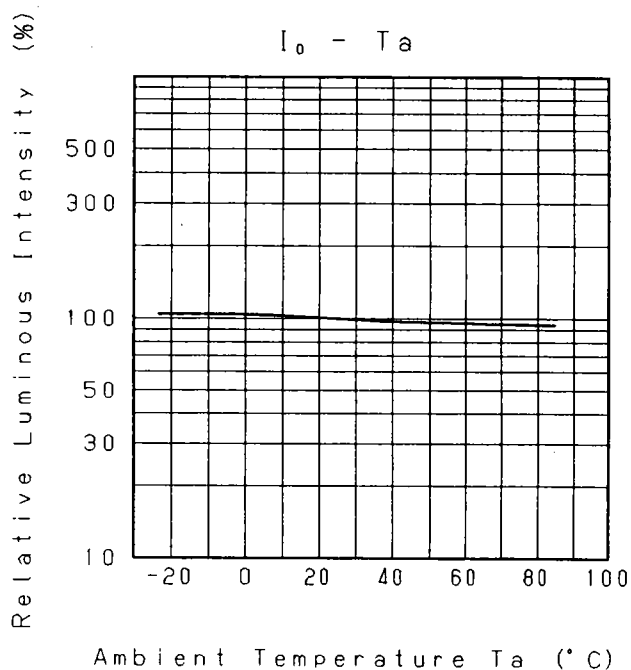
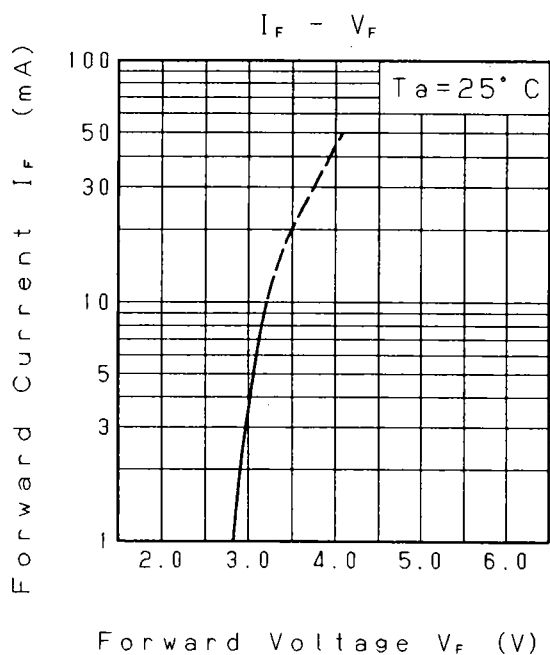

Sep. 1. 1999			

Approved	Checked	Designed
T. Akeda	M. Imai	T. Takata

DEVELOPMENT SPECIFICATION

P/N: LNJ911W8BRA

Relative Luminous Intensity
Wavelength Characteristics

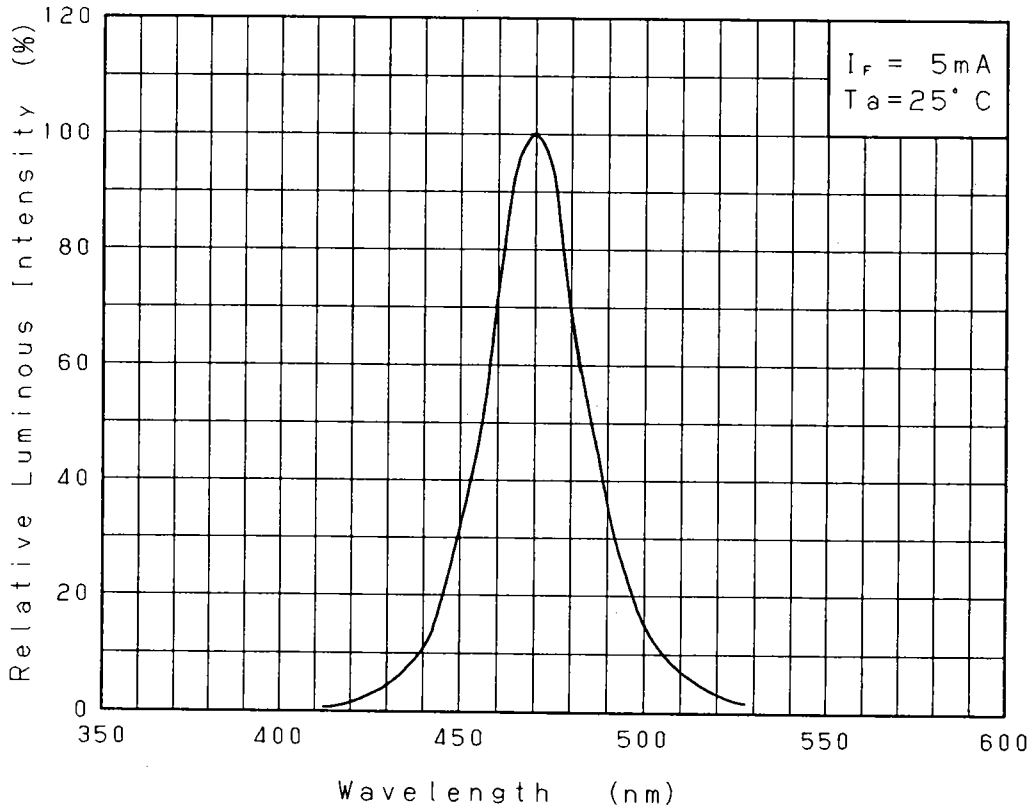

Directive Characteristics

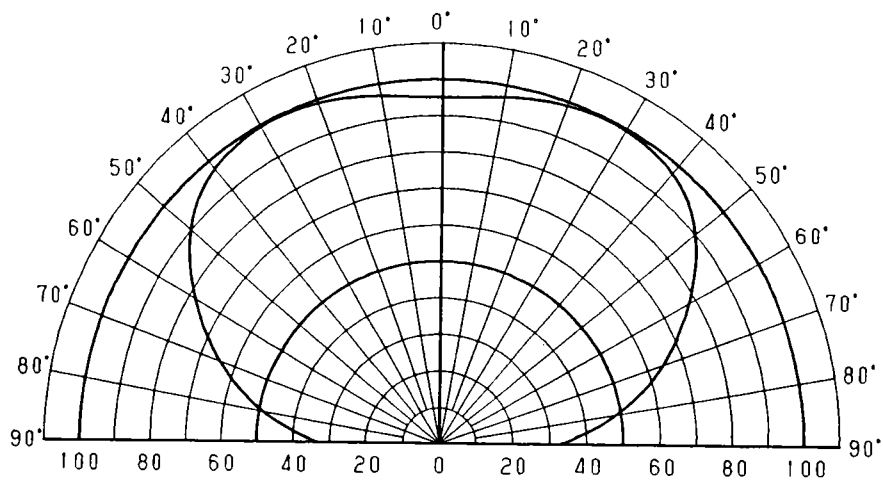

Relative Luminous Intensity (%)

Ser. 1.1999

Approved	Checked	Designed	DEVELOPMENT SPECIFICATION (TEMPORARY OUTLINE) P/N: LNJ911W8BRA		
<i>T. Okada</i>	<i>M. Imai</i>	<i>T. Tabata</i>			

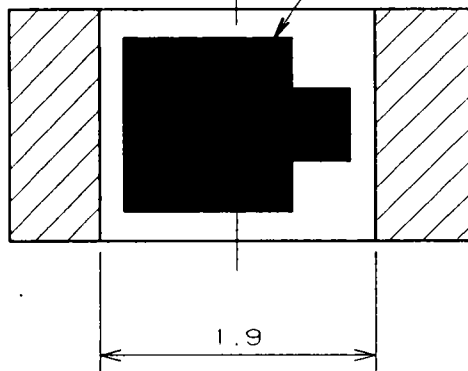
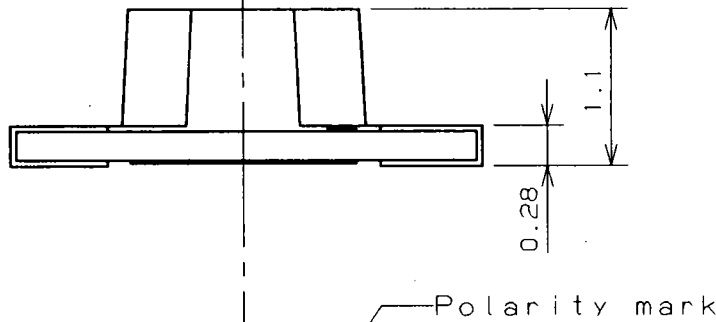
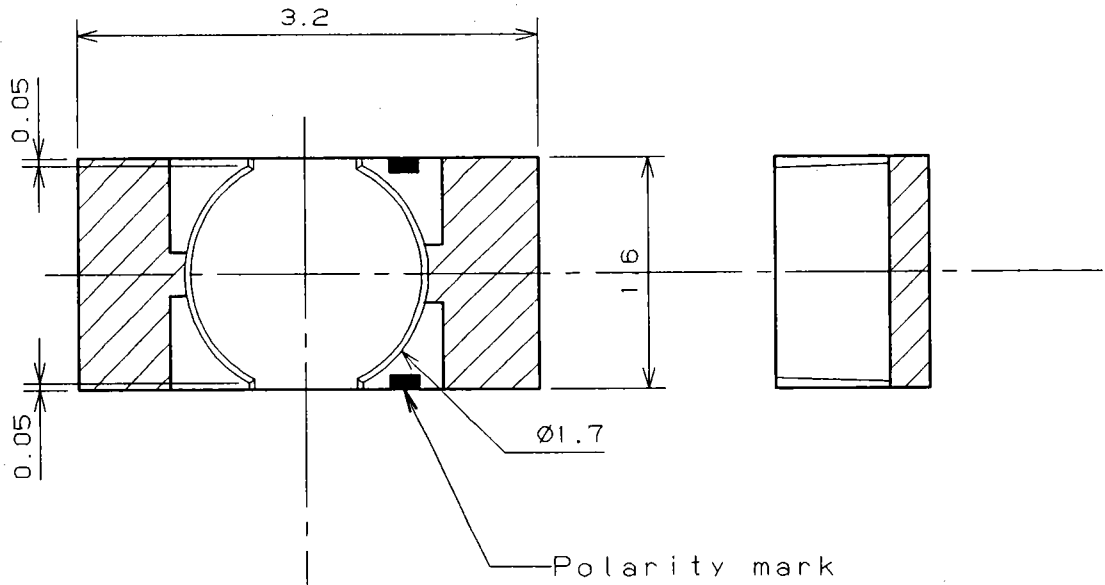

- (NOTE)
- 1. Unit: mm
 - 2. Tolerance unless specified is ± 0.15 .
 - 3. indicate Au terminal.

Sep. 1.1999			
-------------	--	--	--

单击下面可查看定价，库存，交付和生命周期等信息

[>>Panasonic\(松下\)](#)