

Technical reference AC Servo Motor & Driver MINAS A4-series

- This product is for industrial equipment. Don't use this product at general household.



- Thank you very much for your purchase of Panasonic AC Servo Motor & Driver, MINAS A4-series.
- Before use, refer this technical reference and safety instructions to ensure proper use. Keep this technical reference and read when necessary.
- Make sure to forward this technical reference for safety to the final user.

If you are the first user of this product, please be sure to purchase and read the optional Engineering Material (DV0P4210), or downloaded Instruction Manual from our Web Site.

[Web address of Motor Company, Matsushita Electric Industrial Co., Ltd.]
http://industrial.panasonic.com/ww/i_e/25000/motor_fa_e/motor_fa_e.html

<Contents>	page	<Contents>	page
1. Introduction	B2	4. Parameter	B27
On Opening the Package	B2	Outline of Parameter	B27
Check of the Driver Model	B2	How to Set	B27
Check of the Motor Model	B3	Setup with the Front Panel	B27
2. Installation	B4	Outline of PANATERM®	B28
Driver	B4	Setup with the Console	B28
Motor	B6	How to Connect	B29
Console	B8	Composition and List of Parameters	B30
3. System Configuration and Wiring	B10	5. Protective Functions	B36
Overall Wiring (Connecting Example of C-frame, 3-phase)	B10	Protective Function (What Is Error Code ?)	B36
Overall Wiring (Connecting Example of E-frame)	B12	6. Maintenance and Inspections	B38
Driver and List of Applicable Peripheral Equipments	B14	7. Conformity to EC Directives and UL Standards	B40
Wiring of the Main Circuit (A to D-frame)	B16	Composition of Peripheral Equipments	B41
Wiring of the Main Circuit (E and F-frame)	B17	Conformity to UL Standards	B44
Wiring method to connector (A to D-frame)	B18	8. Built-in Holding Brake	B45
Wiring to the Connector, CN X6 (Connection to Encoder)	B22	9. Dynamic Brake	B47
Wiring for Typical Control Modes to the Connector CN X5	B24	10. Check of the Combination of the Driver and the Motor	B48
		After-Sale Service (Repair)	B51

1. Introduction

On Opening the Product Package

- Make sure that the model is what you have ordered.
- Check if the product is damaged or not during transportation.
- Check if the instruction manual is attached or not.
- Check if the power connector and motor connectors (CN X1 and CN X2 connectors) are attached or not (A to D-frame).

Contact to a dealer if you find any failures.

Check of the Driver Model

Contents of Name Plate

Model number: MADDT1205
Rated input/output voltage: 200-240V
Rated input/output current: 1.6 A
Rated output of applicable motor: 100W

Serial Number: P04110001Z
Lot number: 0411
Month of production: 11
Year of production: 0001 (Lower 2 digits of AD year)

Model Designation

M A D D T 1 2 0 5 * * *

1 to 4: Frame-size symbol
 5 to 6: Max. current rating of power device
 7: Power supply
 8 to 9: Current detector rating
 10 to 12: Special specifications (letters and numbers)

Symbol	Frame
MADD	A4-series, A-frame
MBDD	A4-series, B-frame
MCDD	A4-series, C-frame
MDDD	A4-series, D-frame
MEDD	A4-series, E-frame
MFDD	A4-series, F-frame

Symbol	Current rating
T1	10A
T2	15A
T3	30A
T5	50A
T7	70A
TA	100A
TB	150A

Symbol	Specifications
1	Single phase, 100V
2	Single phase, 200V
3	3-phase, 200V
5	Single/3-phase, 200V

Symbol	Current rating
05	5A
07	7.5A
10	10A
15	15A
20	20A
30	30A
40	40A
64	64A
90	90A
A2	120A

Check of the Motor Model

Contents of Name Plate

Model: MSMD5AZS1S
Rated input voltage/current: 200-240V, 1.6 A
Rated output: 0.2 kW
Rated rotational speed: 3000 r/min

Serial Number: 04110001
Lot number: 0411
Month of production: 11
Year of production: 0001 (Lower 2 digits of AD year)

Model Designation

M S M D 5 A Z S 1 S * *

1 to 4: Motor rated output
 5 to 6: Voltage specifications
 7: Motor structure
 8: Design order
 9: Standard
 10: Special specifications (letters and numbers)
 11 to 12: Motor structure

Symbol	Type
MAMA	Ultra low inertia (100W to 750W)
MQMA	Low inertia (100W to 400W)
MSMD	Low inertia (50W to 750W)
MSMA	Low inertia (1.0kW to 5.0kW)
MDMA	Middle inertia (1.0kW to 5.0kW)
MHMA	High inertia (500W to 5.0kW)
MFMA	Middle inertia (400W to 4.5kW)
MGMA	Middle inertia (900W to 4.5kW)

Symbol	Output	Symbol	Output
5A	50W	15	1.5kW
01	100W	20	2.0kW
02	200W	25	2.5kW
04	400W	30	3.0kW
05	500W	40	4.0kW
08	750W	45	4.5kW
09	900W	50	5.0kW
10	1.0kW		

Symbol	Specifications
1	100 V
2	200 V
Z	100/200 common (50W only)

Symbol	Format	Pulse count	Resolution	Wire count
P	Incremental	2500P/r	10,000	5-wire
S	Absolute/Incremental common	17bit	131,072	7-wire

Motor structure MSMD, MQMA

Symbol	Shaft		Holding brake		Oil seal	
	Round	Key way	Without	With	Without	With ^{*1}
A	●		●		●	
B	●			●	●	
S		●*2	●		●	
T		●*2		●	●	

MAMA

Symbol	Shaft		Holding brake		Oil seal	
	Round	Key way	Without	With	Without	With
A	●		●		●	
B	●			●	●	
E		●	●		●	
F		●		●	●	

*1 The product with oil seal is a special order product.

*2 Key way with center tap

Products are standard stock items or build to order items. For details, inquire of the dealer.

MSMA, MDMA, MFMA, MGMA, MHMA

Symbol	Shaft		Holding brake		Oil seal	
	Round	Key way	Without	With	Without	With
C	●		●			●
D	●			●		●
G		●	●			●
H		●		●		●

2. Installation

Install the driver and the motor properly to avoid a breakdown or an accident.

Driver

Installation Place

- 1) Indoors, where the products are not subjected to rain or direct sun beams. The products are not waterproof.
- 2) Where the products are not subjected to corrosive atmospheres such as hydrogen sulfide, sulfurous acid, chlorine, ammonia, chloric gas, sulfuric gas, acid, alkaline and salt and so on, and are free from splash of inflammable gas, grinding oil, oil mist, iron powder or chips and etc.
- 3) Well-ventilated and low humidity and dust-free place.
- 4) Vibration-free place.

Environmental Conditions

Item	Conditions
Ambient temperature	0°C to 55°C (free from freezing)
Ambient humidity	Less than 90% RH (free from condensation)
Storage temperature	-20°C to 80°C (free from freezing)
Storage humidity	Less than 90% RH (free from condensation)
Vibration	Lower than 5.9m/s ² (0.6G), 10 to 60Hz
Altitude	Lower than 1000m

How to Install

- 1) Rack-mount type. Install in vertical position, and reserve enough space around the servo driver for ventilation.

Base mount type (rear mount) is standard (A to D-frame)

- 2) Use the optional mounting bracket when you want to change the mounting face.

A to D-frame

MADD
MBDD
MCDD
MDD

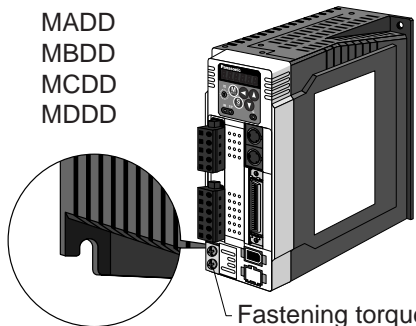

e.g.) In case of C-frame

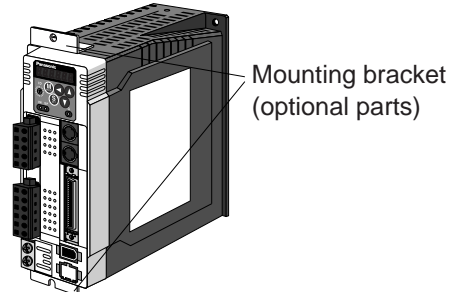

Fastening torque of earth screws (M4) to be 0.39 to 0.59N·m.

E and F-frame

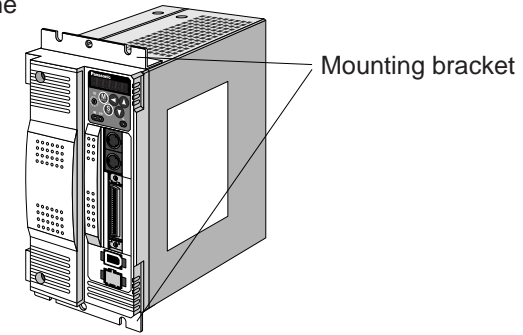

Mounting Direction and Spacing

- Reserve enough surrounding space for effective cooling.
- Install fans to provide uniform distribution of temperature in the control panel.
- Observe the environmental conditions of the control panel described in the next page.

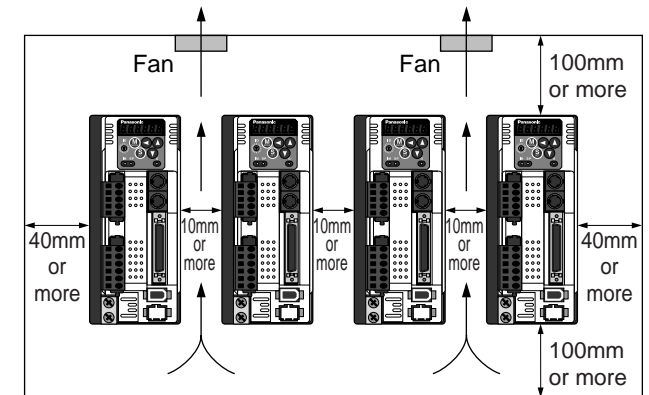

<Note>

It is recommended to use the conductive paint when you make your own mounting bracket, or repaint after peeling off the paint on the machine for installing the products, in order to make noise countermeasure.

Caution on Installation

We have been making the best effort to ensure the highest quality, however, application of exceptionally large external noise disturbance and static electricity, or failure in input power, wiring and components may result in unexpected action. It is highly recommended that you make a fail-safe design and secure the safety in the operative range.

There might be a chance of smoke generation due to the failure of these products. Pay an extra attention when you apply these products in a clean room environment.

2. Installation

Motor

Installation Place

Since the conditions of location affect a lot to the motor life, select a place which meets the conditions below.

- 1) Indoors, where the products are not subjected to rain or direct sun beam. The products are not waterproof.
- 2) Where the products are not subjected to corrosive atmospheres such as hydrogen sulfide, sulfuric acid, chlorine, ammonia, chloric gas, sulfuric gas, acid, alkaline and salt and so on, and are free from splash of inflammable gas, grinding oil, oil mist, iron powder or chips and etc.
- 3) Where the motor is free from grinding oil, oil mist, iron powder or chips.
- 4) Well-ventilated and humid and dust-free place, far apart from the heat source such as a furnace.
- 5) Easy-to-access place for inspection and cleaning
- 6) Vibration-free place.
- 7) Avoid enclosed place. Motor may get hot in those enclosure and shorten the motor life.

Environmental Conditions

Item		Condition
Ambient temperature		0°C to 40°C (free from freezing) *1
Ambient humidity		Less than 85% RH (free from condensation)
Storage temperature		-20°C to 80°C (free from freezing) *2
Storage humidity		Less than 85% RH (free from condensation)
Vibration	Motor only	Lower than 49m/s ² (5G) at running, 24.5m/s ² (2.5G) at stall
Impact	Motor only	Lower than 98m/s ² (10G)
Enclosure rating	Motor only	IP65 (except rotating portion of output shaft and lead wire end) • These motors conform to the test conditions specified in EN standards (EN60529, EN60034-5). Do not use these motors in application where water proof performance is required such as continuous wash-down operation.

*1 Ambient temperature to be measured at 5cm away from the motor.

*2 Permissible temperature for short duration such as transportation.

How to Install

You can mount the motor either horizontally or vertically as long as you observe the followings.

- 1) Horizontal mounting
 - Mount the motor with cable outlet facing downward for water/oil countermeasure.
- 2) Vertical mounting
 - Use the motor with oil seal (non-standard) when mounting the motor with gear reducer to prevent the reducer oil/grease from entering to the motor.
- 3) For mounting dimensions, refer to the technical reference. (DV0P4210)

Oil/Water Protection

- 1) Don't submerge the motor cable to water or oil.
- 2) Install the motor with the cable outlet facing downward.
- 3) Avoid a place where the motor is subjected to oil or water.
- 4) Use the motor with an oil seal when used with the gear reducer, so that the oil may not enter to the motor through shaft.

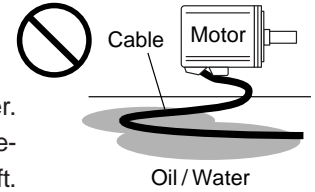

Stress to Cables

- 1) Avoid a stress application to the cable outlet and connecting portion by bending or self-weight.
- 2) Especially in an application where the motor itself travels, fix the attached cable and contain the extension junction cable into the bearer so that the stress by bending can be minimized.
- 3) Take the cable bending radius as large as possible. (Minimum R20mm)

Permissible Load to Output Shaft

- 1) Design the mechanical system so that the applied radial load and/or thrust load to the motor shaft at installation and at normal operation can meet the permissible value specified to each model.
- 2) Pay an extra attention when you use a rigid coupling. (Excess bending load may damage the shaft or deteriorate the bearing life.)
- 3) Use a flexible coupling with high stiffness designed exclusively for servo application in order to make a radial thrust caused by micro misalignment smaller than the permissible value.
- 4) For permissible load of each model, refer to the technical reference. (DV0P4210)

Notes on Installation

- 1) Do not apply direct impact to the shaft by hammer while attaching/detaching a coupling to and from the motor shaft.
(Or it may damage the encoder mounted on the other side of the shaft.)
- 2) Make a full alignment. (incomplete alignment may cause vibration and damage the bearing.)
- 3) If the motor shaft is not electrically grounded, it may cause electrolytic corrosion to the bearing depending on the condition of the machine and its mounting environment, and may result in the bearing noise. Check and verification by customer is required.

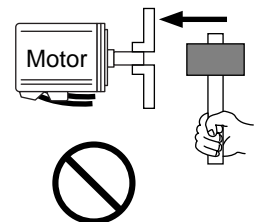

2. Installation

Console

Installation Place

- 1) Indoors, where the products are not subjected to rain or direct sun beam. The products are not waterproof.
- 2) Where the products are not subjected to corrosive atmospheres such as hydrogen sulfide, sulfurous acid, chlorine, ammonia, chloric gas, sulfuric gas, acid, alkaline and salt and so on, and are free from splash of inflammable gas, grinding oil, oil mist, iron powder or chips and etc.
- 3) Well-ventilated and low humidity and dust-free place.
- 4) Easy-to-access place for inspection and cleaning

Environmental Conditions

Item	Condition
Ambient temperature	0°C to 55°C (free from freezing)
Ambient humidity	Less than 90% RH (free from condensation)
Storage temperature	-20°C to 80°C (free from freezing)
Storage humidity	Less than 90% RH (free from condensation)
Vibration	Lower than 5.9m/s ² (0.6G), 10 to 60Hz
Impact	Conform to JISC0044 (Free fall test, 1m for 2 directions, 2 cycles)
Altitude	Lower than 1000m

<Cautions>

- Do not give strong impact to the products.
- Do not drop the products.
- Do not pull the cables with excess force.
- Avoid the place near to the heat source such as a heater or a large winding resistor.

How to Connect

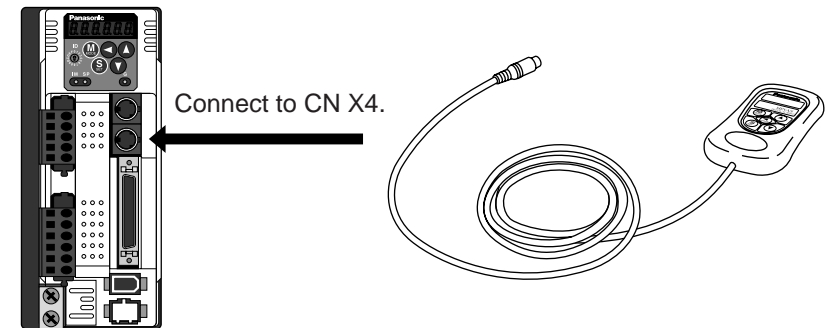

<Remarks>

- Connect the console connector securely to CN X4 connector of the driver.
- Never pull the cable to plug in or plug out.

3. System Configuration and Wiring

Overall Wiring (Connecting Example of C-frame, 3-phase)

• Wiring of the Main Circuit

Circuit Breaker (NFB)

Use the circuit breaker matching capacity of the power source to protect the power lines.

Noise Filter (NF)

Prevents external noise from the power lines. And reduces an effect of the noise generated by the servo driver.

Magnetic Contactor (MC)

Turns on/off the main power of the servo driver.

Use a surge absorber together with this.

• **Never start nor stop the servo motor with this Magnetic Contactor.**

Reactor (L)

Reduces harmonic current of the main power.

For specifications, refer to the downloaded Instruction Manual from our Web Site.

Pin RB1 (6-pin), RB2 (4-pin), and RB3 (5-pin)

• RB2 and RB3 to be kept shorted for normal operation.

• **When the capacity shortage of the regenerative resistor is found, disconnect a shorting bar between RB2 and RB3, then connect the external regenerative resistor between RB1 and RB2.**

(Note that no regenerative resistor is equipped in Frame A and B type. **Install an external regenerative resistor on incombustible material, such as metal.** Follow the same wiring connection as the above.)

• When you connect an external regenerative resistor, set up Parameter No. 6C to 1 or 2.

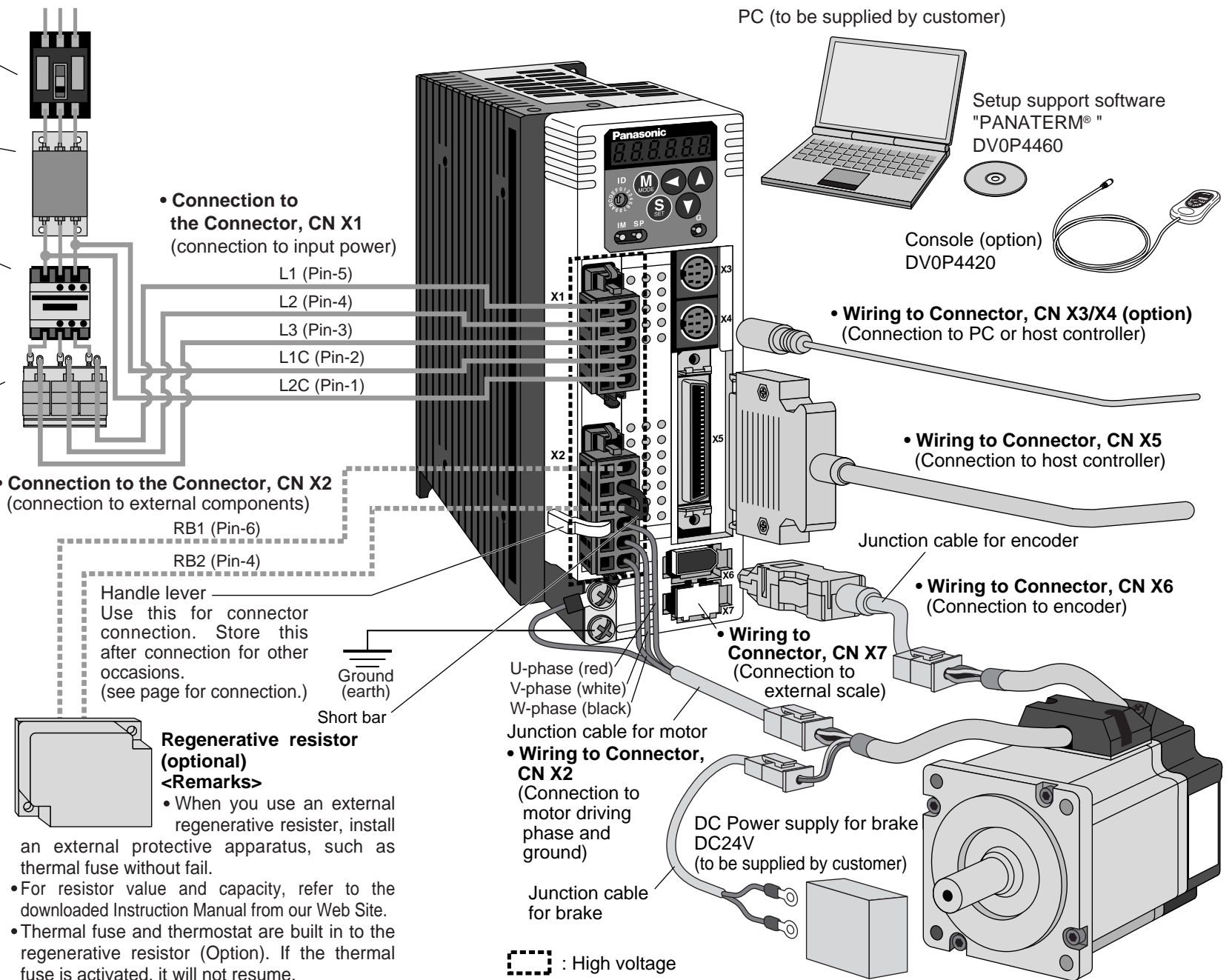

• Connection to the Connector, CN X2 (connection to external components)

- RB1 (Pin-6)
- RB2 (Pin-4)

Handle lever
Use this for connector connection. Store this after connection for other occasions. (see page for connection.)

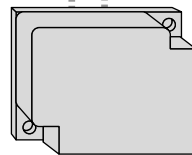

Regenerative resistor (optional)

<Remarks>

- When you use an external regenerative resistor, install an external protective apparatus, such as thermal fuse without fail.
- For resistor value and capacity, refer to the downloaded Instruction Manual from our Web Site.
- Thermal fuse and thermostat are built in to the regenerative resistor (Option). If the thermal fuse is activated, it will not resume.

PC (to be supplied by customer)

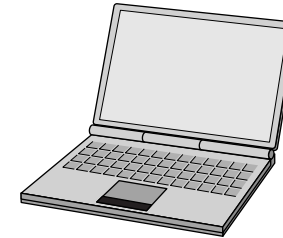

Setup support software "PANATERM®" DV0P4460



Console (option) DV0P4420

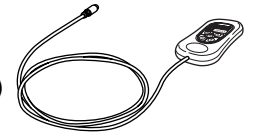

• Wiring to Connector, CN X3/X4 (option) (Connection to PC or host controller)

• Wiring to Connector, CN X5 (Connection to host controller)

Junction cable for encoder

• Wiring to Connector, CN X6 (Connection to encoder)

• Wiring to Connector, CN X7 (Connection to external scale)

U-phase (red)
V-phase (white)
W-phase (black)
Junction cable for motor

• Wiring to Connector, CN X2 (Connection to motor driving phase and ground)

DC Power supply for brake DC24V (to be supplied by customer)

Junction cable for brake

⋯ : High voltage

3. System Configuration and Wiring

Overall Wiring (Connecting Example of E-frame)

• Wiring of the Main Circuit

Circuit Breaker (NFB)

Use the circuit breaker matching capacity of the power source to protect the power lines.

Noise Filter (NF)

Prevents external noise from the power lines. And reduces an effect of the noise generated by the servo driver.

Magnetic Contactor (MC)

Turns on/off the main power of the servo driver. Use a surge absorber together with this.

• **Never start nor stop the servo motor with this Magnetic Contactor.**

Reactor (L)

Reduces harmonic current of the main power.

For specifications, refer to the downloaded Instruction Manual from our Web Site.

Pin P, B1 and B2...

B1 and B2 to be kept shorted for normal operation.

• **When the capacity shortage of the regenerative resistor is found, disconnect a short bar between B1 and B2, then connect the external regenerative resistor between P and B2.**

Install an external regenerative resistor on incombustible material, such as metal. Follow the same wiring connection as the above.

• When you connect an external regenerative resistor, set up Parameter No. 6C to 1 or 2.

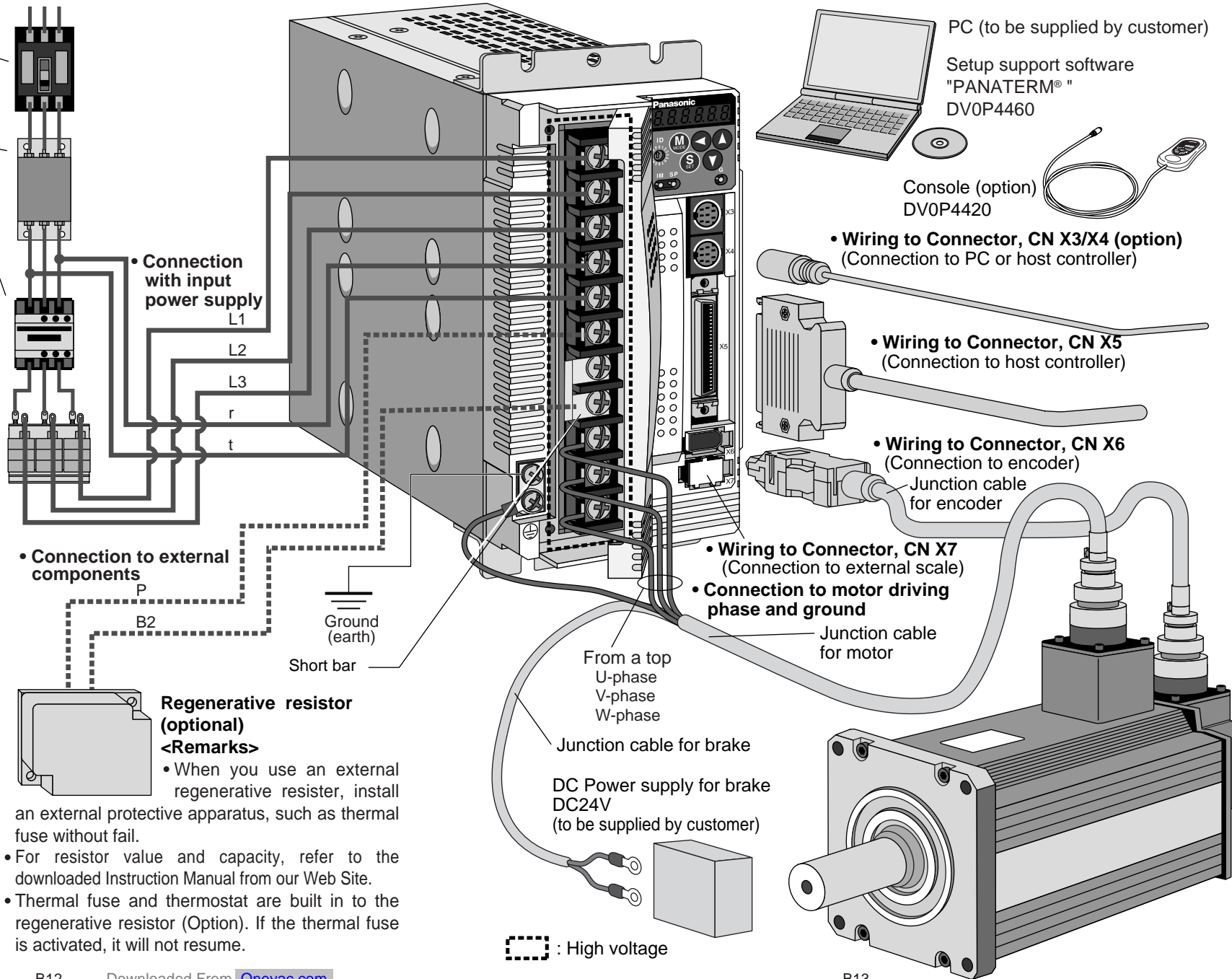

Regenerative resistor (optional)
<Remarks>
 • When you use an external regenerative resistor, install an external protective apparatus, such as thermal fuse without fail.
 • For resistor value and capacity, refer to the downloaded Instruction Manual from our Web Site.
 • Thermal fuse and thermostat are built in to the regenerative resistor (Option). If the thermal fuse is activated, it will not resume.

⋮ : High voltage

3. System Configuration and Wiring

Driver and List of Applicable Peripheral Equipments

Driver	Applicable motor	Voltage	Rated output	Required Power (at the rated load)	Circuit breaker (rated current)	Noise filter	Surge absorber	Noise filter for signal	Magnetic contactor	Cable diameter (main circuit)	Cable diameter (control circuit)	Connection
MADD	MSMD	Single phase, 100V	50W to 100W	approx. 0.4kVA	10A	DV0P4170	DV0P4190		BMFT61041N (3P+1a)	0.75 to 2.0mm ² AWG 14 to 18		Connection to exclusive connector
	MQMA	100V	100W	approx. 0.4kVA								
	MSMD	Single phase, 200V	50W to 200W	approx. 0.5kVA								
	MQMA		100W	approx. 0.3kVA								
			200W	approx. 0.5kVA								
	MAMA		100W	approx. 0.3kVA								
MBDD	MSMD	Single phase, 100V	200W	approx. 0.5kVA	15A	DV0P4180	DV0P1460		BMFT61041N (3P+1a)	0.75mm ² AWG18		
	MQMA	Single phase, 200V	400W	approx. 0.9kVA								
	MSMD	Single/3-phase, 200V	750W	approx. 1.3kVA								
	MQMA		400W	approx. 0.9kVA								
MCDD	MAMA	Single/3-phase, 200V	400W	approx. 0.9kVA	15A	DV0P4180	DV0P1460		BMFT61542N (3P+1a)	0.75mm ² AWG18		
	MSMD		750W	approx. 1.3kVA								
	MFMA		400W	approx. 0.9kVA								
	MHMA		500W	approx. 1.1kVA								
	MAMA		750W	approx. 1.6kVA								
MDDD	MDMA	Single/3-phase, 200V	1.0kW	approx. 1.8kVA	20A	DV0P1450	DV0P1450		BMFT61842N (3P+1a)	2.0mm ² AWG14		
	MHMA		1.0kW	approx. 1.8kVA								
	MGMA		900W	approx. 1.8kVA								
	MSMA		1.0kW	approx. 1.8kVA								
	MHMA		1.5kW	approx. 2.3kVA								
	MDMA											
	MSMA											
	MFMA											
MEDD	MDMA	3-phase, 200V	2.0kW	approx. 3.3kVA	30A				BMF6352N (3P+2a2b)	2.0mm ² AWG14	Terminal block M5 11.0 or smaller 	
	MSMA		2.5kW	approx. 3.8kVA								
	MHMA											
	MFMA											

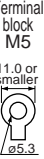
Driver	Applicable motor	Voltage	Rated output	Required Power (at the rated load)	Circuit breaker (rated current)	Noise filter	Surge absorber	Noise filter for signal	Magnetic contactor	Cable diameter (main circuit)	Cable diameter (control circuit)	Connection				
MFDD	MGMA	3-phase, 200V	2.0kW	approx. 3.8kVA	50A	DV0P3410	DV0P1450	DV0P1460	BMF6352N (3P+2a2b)	3.5mm ² AWG12	0.75mm ² AWG18	Terminal block M5 11.0 or smaller 				
	MDMA		3.0kW	approx. 4.5kVA												
	MHMA															
	MSMA															
	MGMA															
	MDMA															
	MHMA															
	MSMA		4.0kW	approx. 6kVA						BMF6652N (3P+2a2b)			5.3mm ² AWG10			
	MFMA													4.5kW	approx. 6.8kVA	
	MGMA															
	MDMA															
	MHMA															
MSMA																

- Select a single and 3-phase common specifications according to the power source.
- Manufacturer of circuit breaker and magnetic contactor : Matsushita Electric Works. To comply to EC Directives, install a circuit breaker between the power and the noise filter without fail, and the circuit breaker should conform to IEC Standards and UL recognized (Listed and  marked). 5000Arms, 240V is the maximum capacity to be delivered to the circuit of 750W or larger model when the maximum current value of the circuit breaker is limited to 20A.
- For details of noise filters, refer to P.B42, "Noise Filter".

<Remarks>

- Select and use the circuit breaker and noise filter with matching capacity to those of the power source, considering the load conditions as well.
- Terminal block and protective earth terminal
Use a copper conductor cable with temperature rating of 60°C or higher. Protective earth terminal is M4 for A to D-frame, and M5 for E and F-frame. Larger tightening torque of the screw than the max. value (M4 : 1.2 N·m, M5 : 2.0 N·m) may damage the terminal block.
- Earth cable diameter should be 2.0mm² (AWG14) or larger for 50W to 2.0kW model, and 3.5mm² (AWG12) or larger for 2.5kW to 4.0kW, and 5.3mm² (AWG10) or larger for 4.5kW to 5kW model.
- Use the attached exclusive connectors for A to D-frame, and maintain the peeled off length of 8 to 9mm.
- Tightening torque of the screws for connector (CN X5) for the connection to the host to be 0.3 to 0.35 N·m. Larger tightening torque than these may damage the connector at the driver side.

3. System Configuration and Wiring

Wiring of the Main Circuit (A to D-frame)

- Wiring should be performed by a specialist or an authorized personnel.
- Do not turn on the power until the wiring is completed.

Tips on Wiring

- 1) Peel off the insulation cover of the cable.
(Observe the dimension as the right fig. shows.)
- 2) Insert the cable to the connector detached from the driver. (See P.B18 for details.)
- 3) Connect the wired connector to the driver.

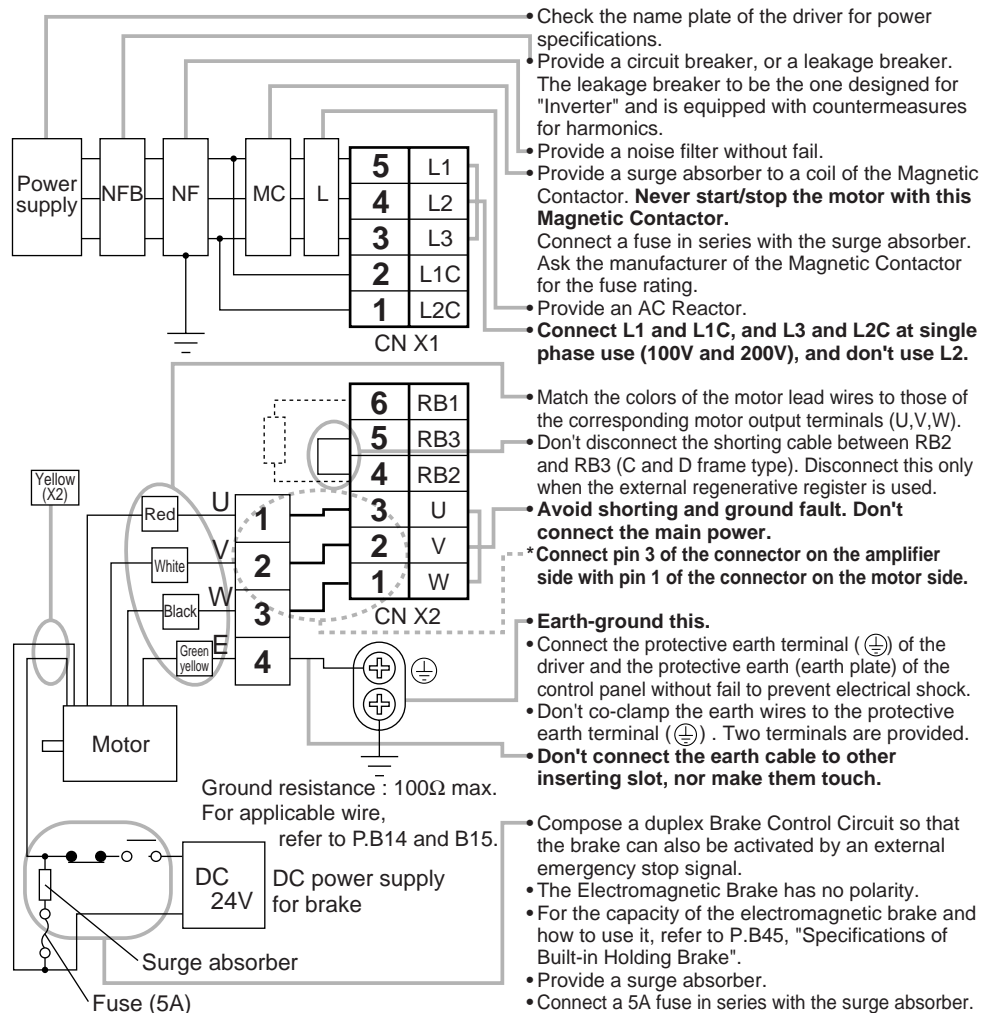
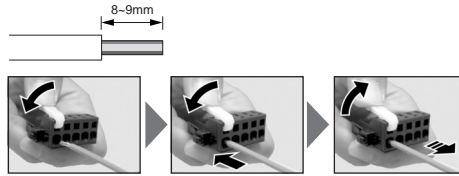

Wiring of the Main Circuit (E and F-frame)

- Wiring should be performed by a specialist or an authorized personnel.
- Do not turn on the power until the wiring is completed.

Tips on Wiring

- 1) Take off the cover fixing screws, and detach the terminal cover.
- 2) Make wiring
Use clamp type terminals of round shape with insulation cover for wiring to the terminal block. For cable diameter and size, refer to "Driver and List of Applicable Peripheral Equipments" (P.B14 and B15).
- 3) Attach the terminal cover, and fix with screws.
Fastening torque of cover fixed screw in less than 0.2 N·m.

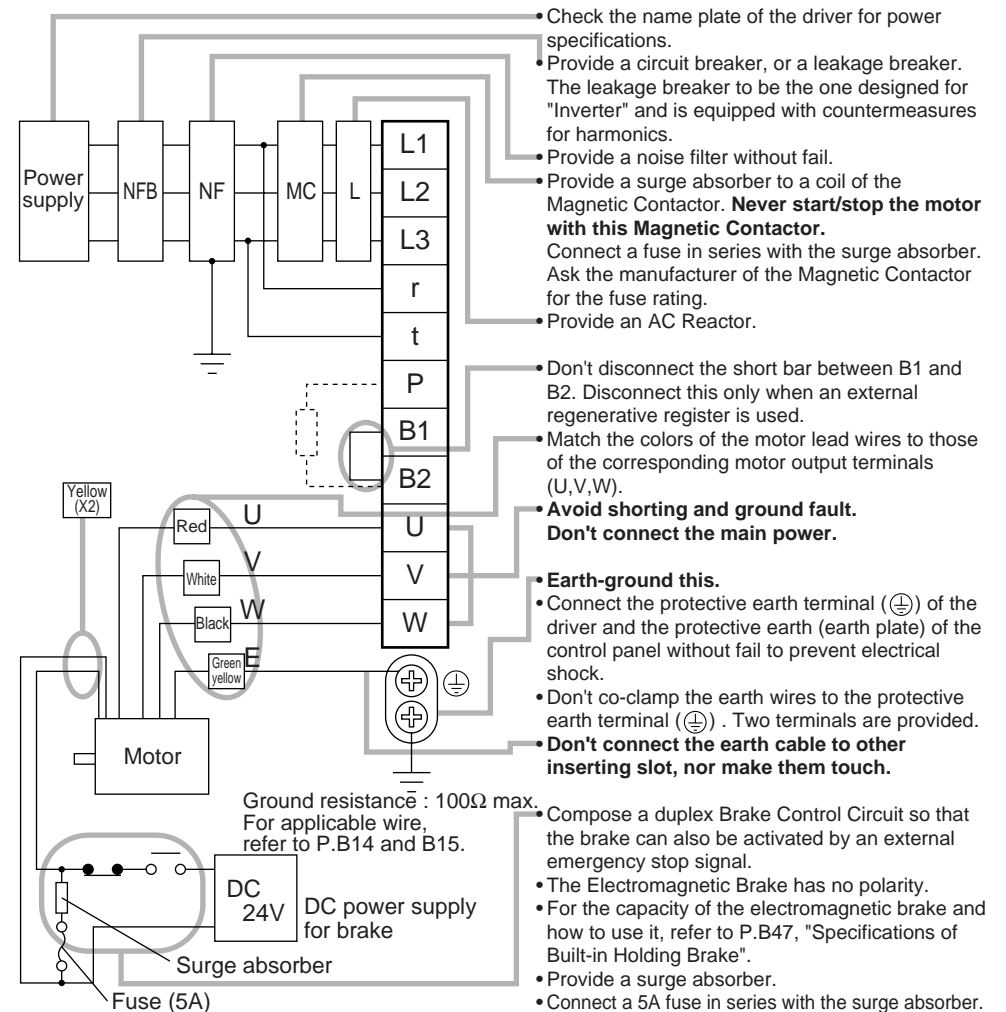

3. System Configuration and Wiring

Wiring method to connector (A to D-frame)

- Follow the procedures below for the wiring connection to the Connector CN X1 and X2.

How to connect

- Peel off the insulation cover of the cable.
(see the right fig for exact length for peeling.)
- Insert the cable to the connector in the following 2 methods.

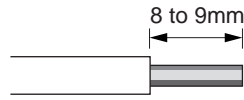

(a) Using handle lever

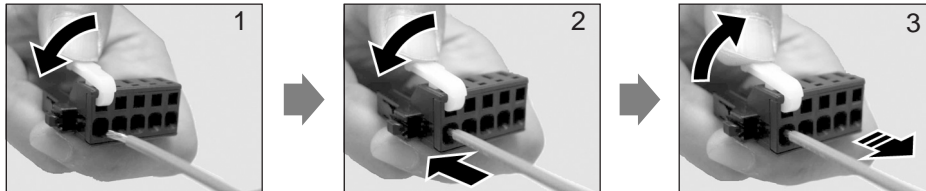

Attach the handle lever to the handling slot on the upper portion. Press down the lever to push down the spring.

Insert the peeled cable while pressing down the lever, until it hits the insertion slot (round hole).

Release the lever.

* You can pull out the cable by pushing down the spring as the above.

(b) Using screw driver

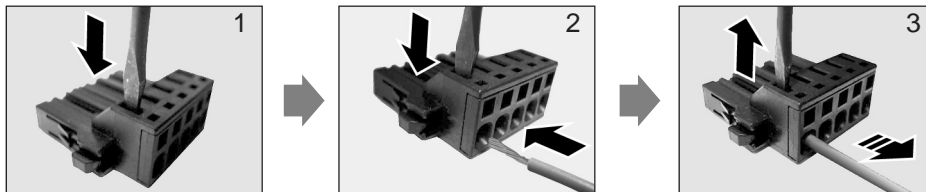

Press the screw driver to the handling slot on the upper portion to push down the spring.

Insert the peeled cable while pressing down the screw driver, until it hits the insertion slot (round hole).

Release the screw driver.

* You can pull out the cable by pushing down the spring as the above.

<CAUTION>

- Peel off the cable with exact length (8 to 9 mm).
- Take off the connector from the Servo Driver before making connection.
- Insert one cable into each one of cable insertion slot.
- Pay attention to injury by screw driver.

Wiring Diagram

Compose the circuit so that the main circuit power will be shut off when an error occurs.

In Case of Single Phase, 100V (A and B-frame)

Power supply Single phase, 100V $+10\%$ to 115V $+10\%$ -15% to -15%

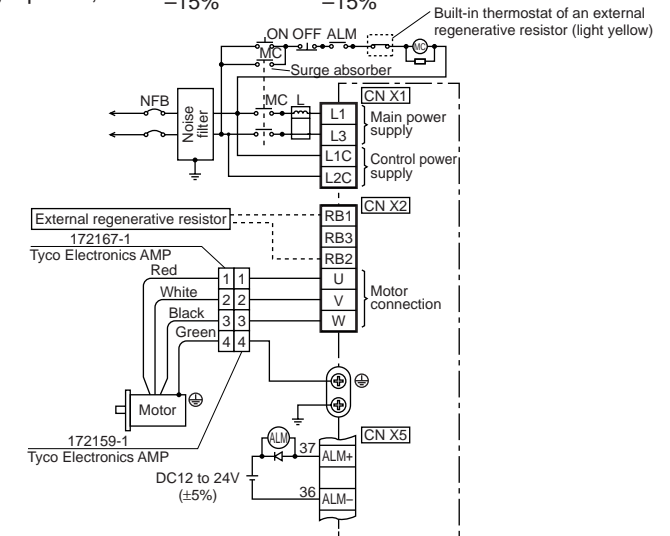

In Case of Single Phase, 200V (A and B-frame)

Power supply Single phase, 200V $+10\%$ to 240V $+10\%$ -15% to -15%

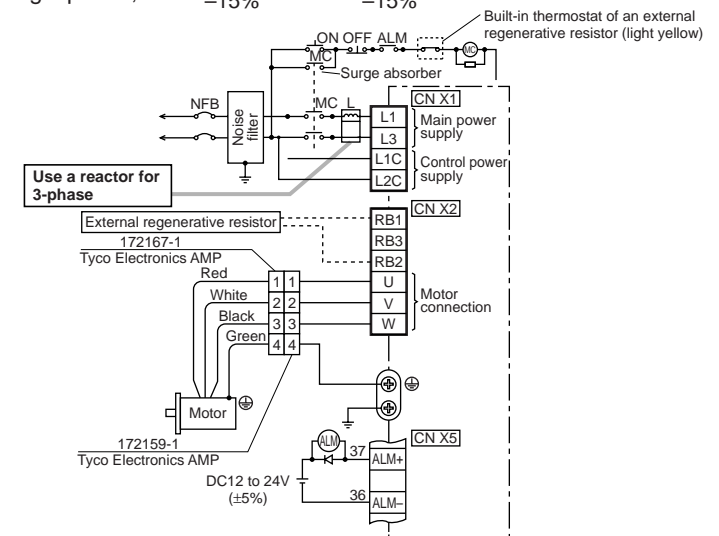

3. System Configuration and Wiring

In Case of Single Phase, 200V (C and D-frame)

Power supply Single phase, 200V ^{+10%}/_{-15%} to 240V ^{+10%}/_{-15%}

<Remarks>

When you use single phase, connect the main power between L1 and L3 terminals.

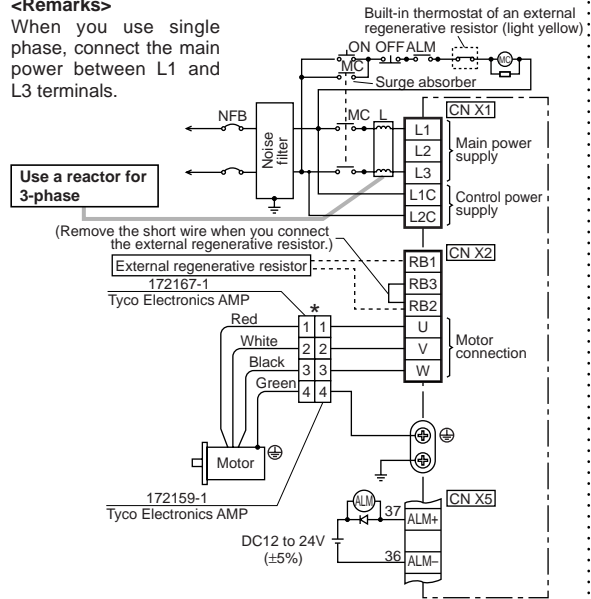

In Case of 3-Phase, 200V (C and D-frame)

Power supply 3-phase, 200V ^{+10%}/_{-15%} to 240V ^{+10%}/_{-15%}

<Remarks>

When you use single phase, connect the main power between L1 and L3 terminals.

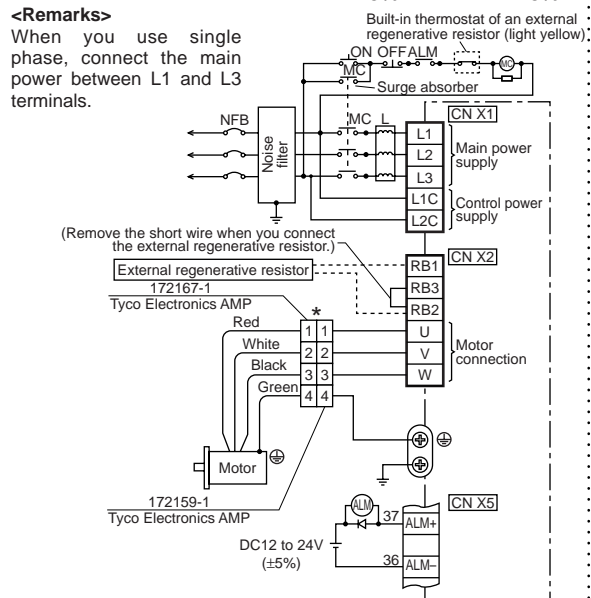

* When you use motor model of MSMA, MDMA, MFMA, MHMA and MGMA, use the connections as the below table shows.

[Motor portion]

Connector : by Japan Aviation Electronics Ind.

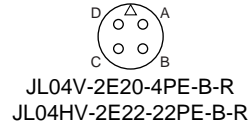

PIN No.	Application
A	U-phase
B	V-phase
C	W-phase
D	Ground

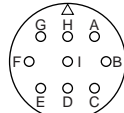

PIN No.	Application
G	Brake
H	Brake
A	NC
F	U-phase
I	V-phase
B	W-phase
E	Ground
D	Ground
C	NC

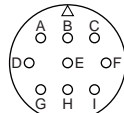

PIN No.	Application
A	Brake
B	Brake
C	NC
D	U-phase
E	V-phase
F	W-phase
G	Ground
H	Ground
I	NC

<Remark>

Do not connect anything to NC.

In Case of 3-Phase, 200V (E and F-frame)

Power supply 3-phase, 200V ^{+10%}/_{-15%} to 230V ^{+10%}/_{-15%}

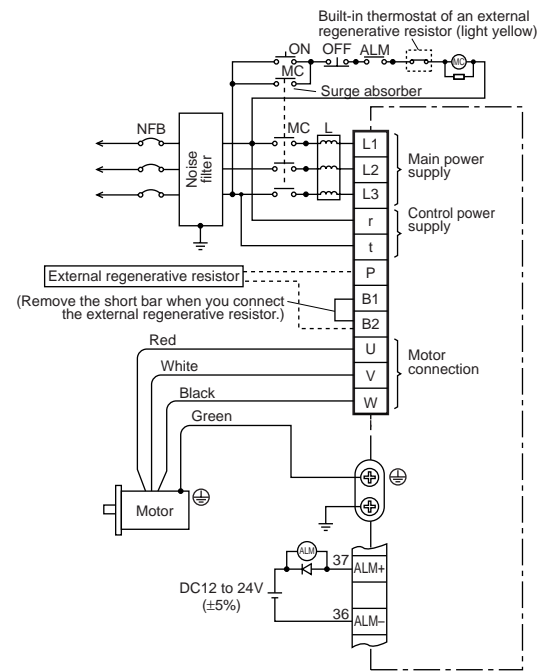

[Motor portion]

Connector : by Japan Aviation Electronics Ind.



PIN No.	Application
A	U-phase
B	V-phase
C	W-phase
D	Ground

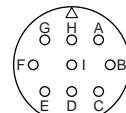

PIN No.	Application
G	Brake
H	Brake
A	NC
F	U-phase
I	V-phase
B	W-phase
E	Ground
D	Ground
C	NC

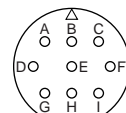

PIN No.	Application
A	Brake
B	Brake
C	NC
D	U-phase
E	V-phase
F	W-phase
G	Ground
H	Ground
I	NC

<Remark>

Do not connect anything to NC.

3. System Configuration and Wiring

Wiring to the Connector, CN X6 (Connection to Encoder)

Wiring Diagram In case of 2500P/r incremental encoder

MSMD 50W to 750W
MAMA 100W to 750W
MQMA 100W to 400W

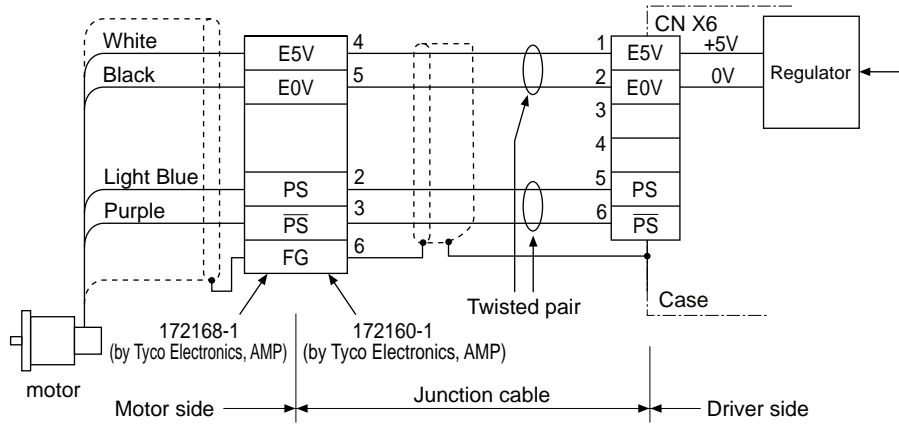

Wiring Diagram In case of 17-bit absolute/incremental encoder

MSMD 50W to 750W
MAMA 100W to 750W
MQMA 100W to 400W

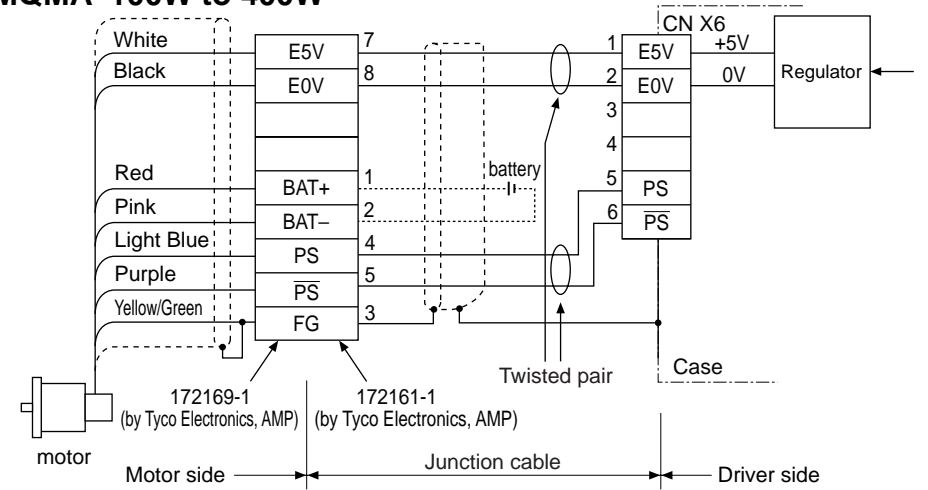

MSMA 1kW to 5kW **MFMA 400W to 4.5kW**
MDMA 1kW to 5kW **MGMA 900W to 4.5kW**
MHMA 500W to 5kW

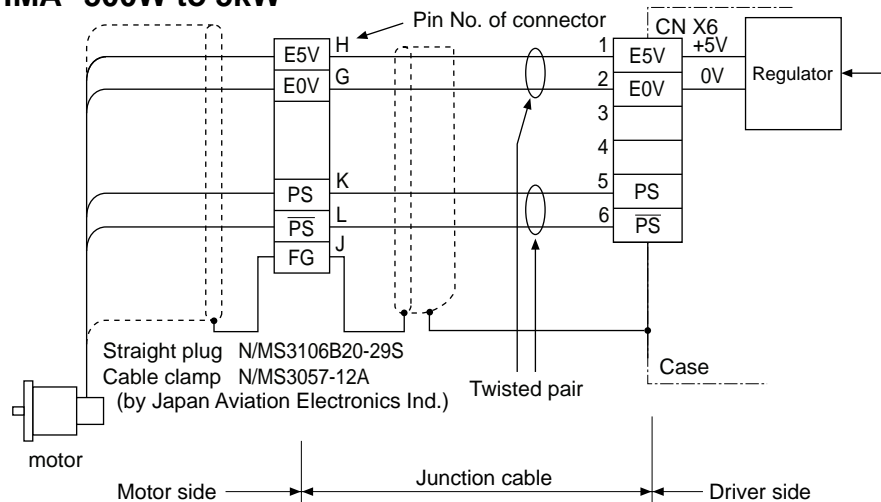

MSMA 1kW to 5kW **MFMA 400W to 4.5kW**
MDMA 1kW to 5kW **MGMA 900W to 4.5kW**
MHMA 500W to 5kW

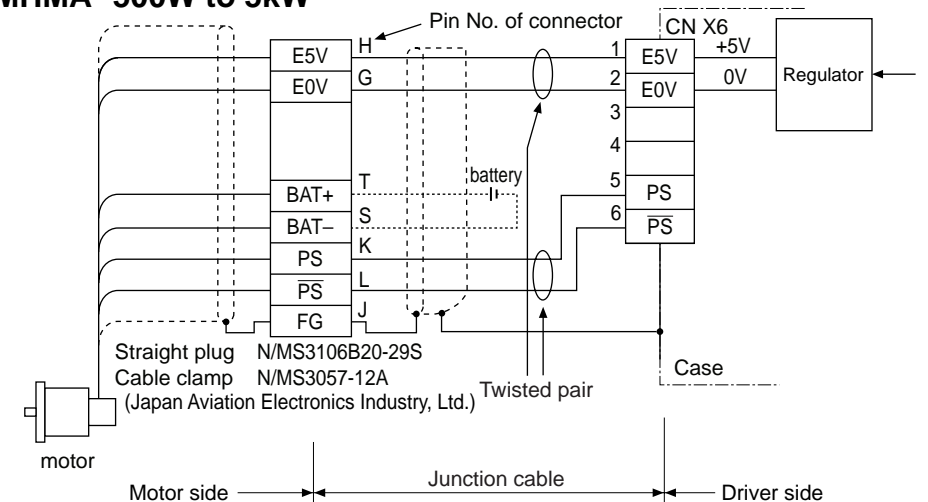

3. System Configuration and Wiring

Wiring for Typical Control Modes to the Connector CN X5

Wiring Example of Position Control Mode

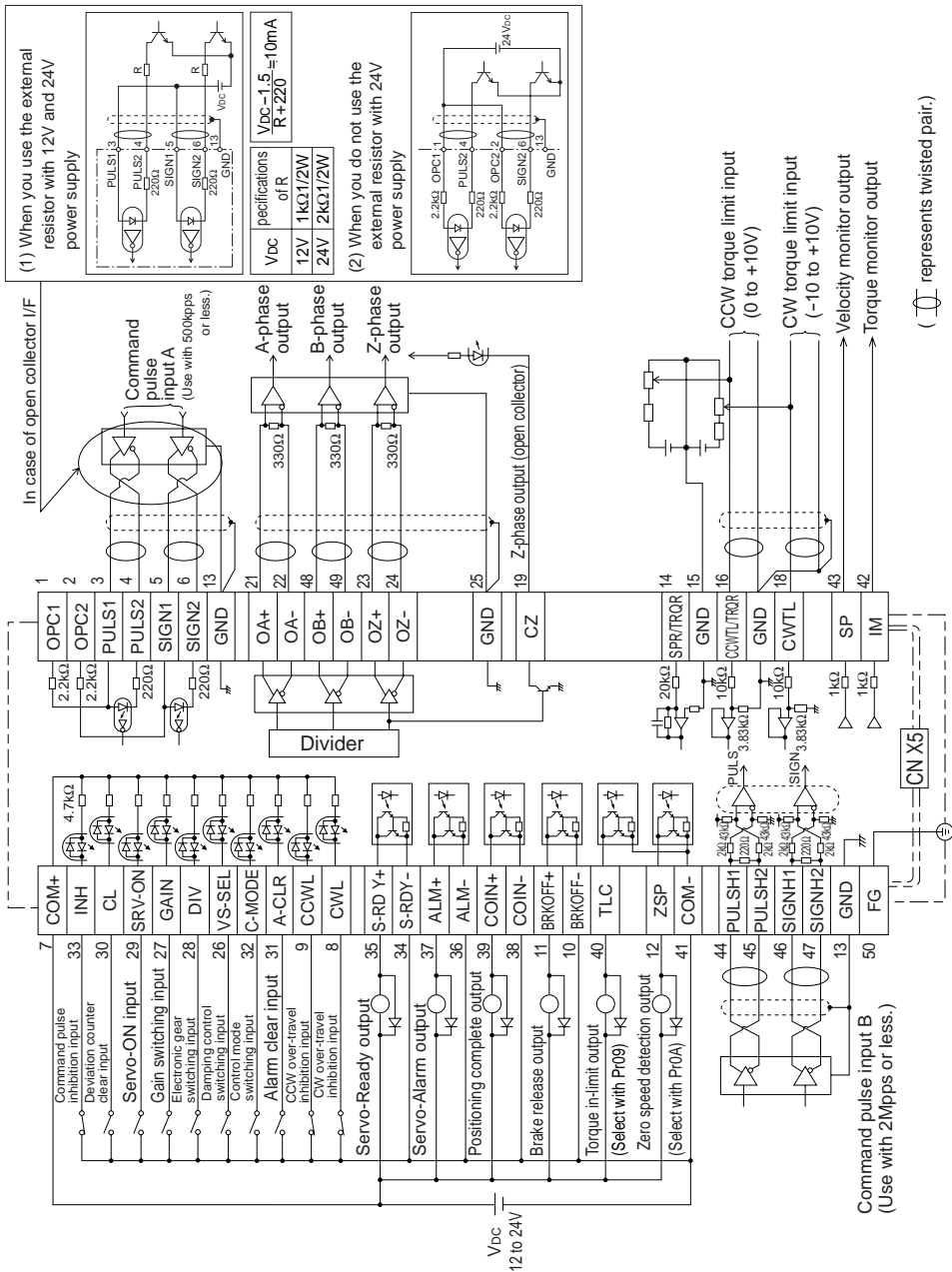

Wiring Example of Velocity Control Mode

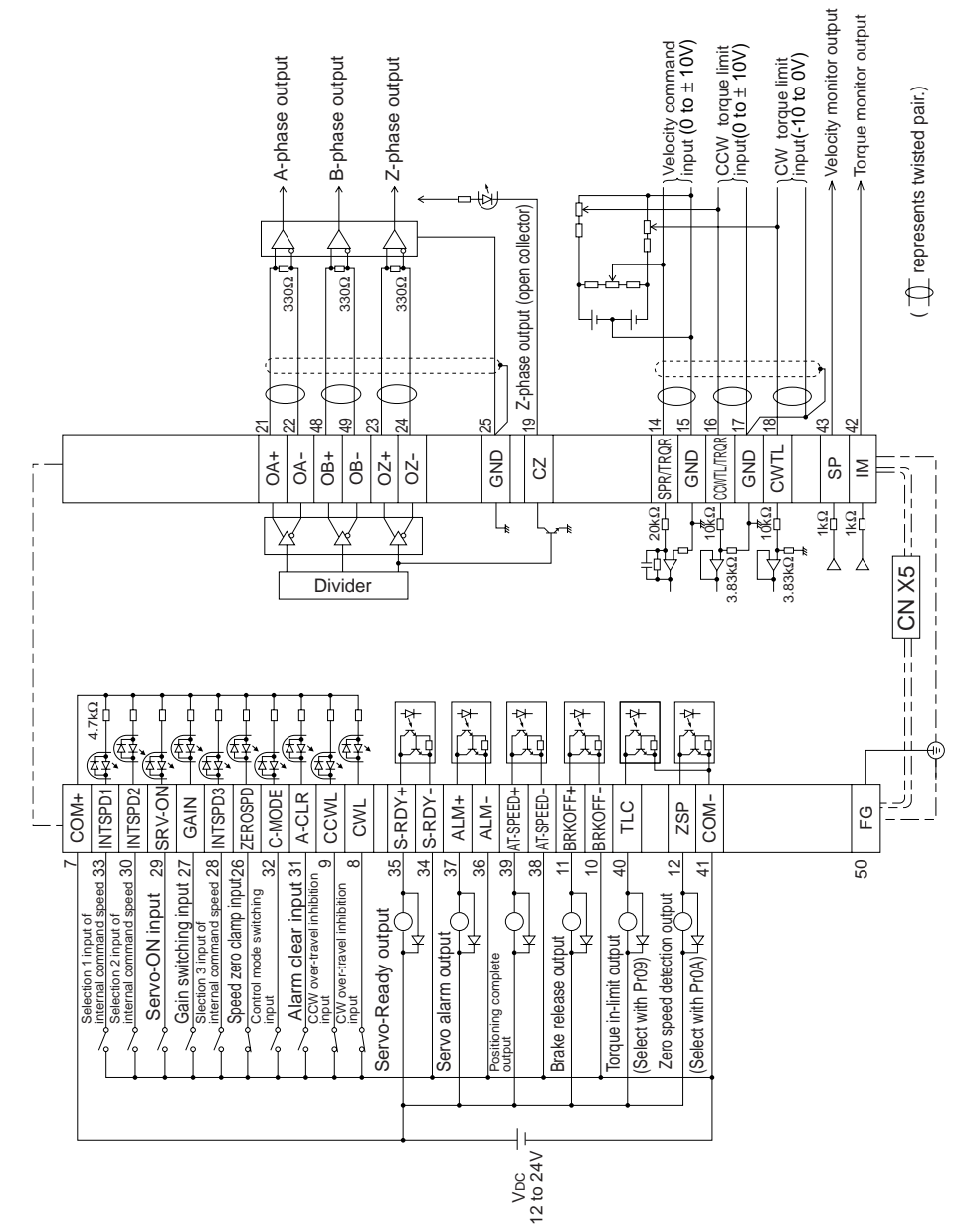

3. System Configuration and Wiring

Wiring Example of Torque Control Mode

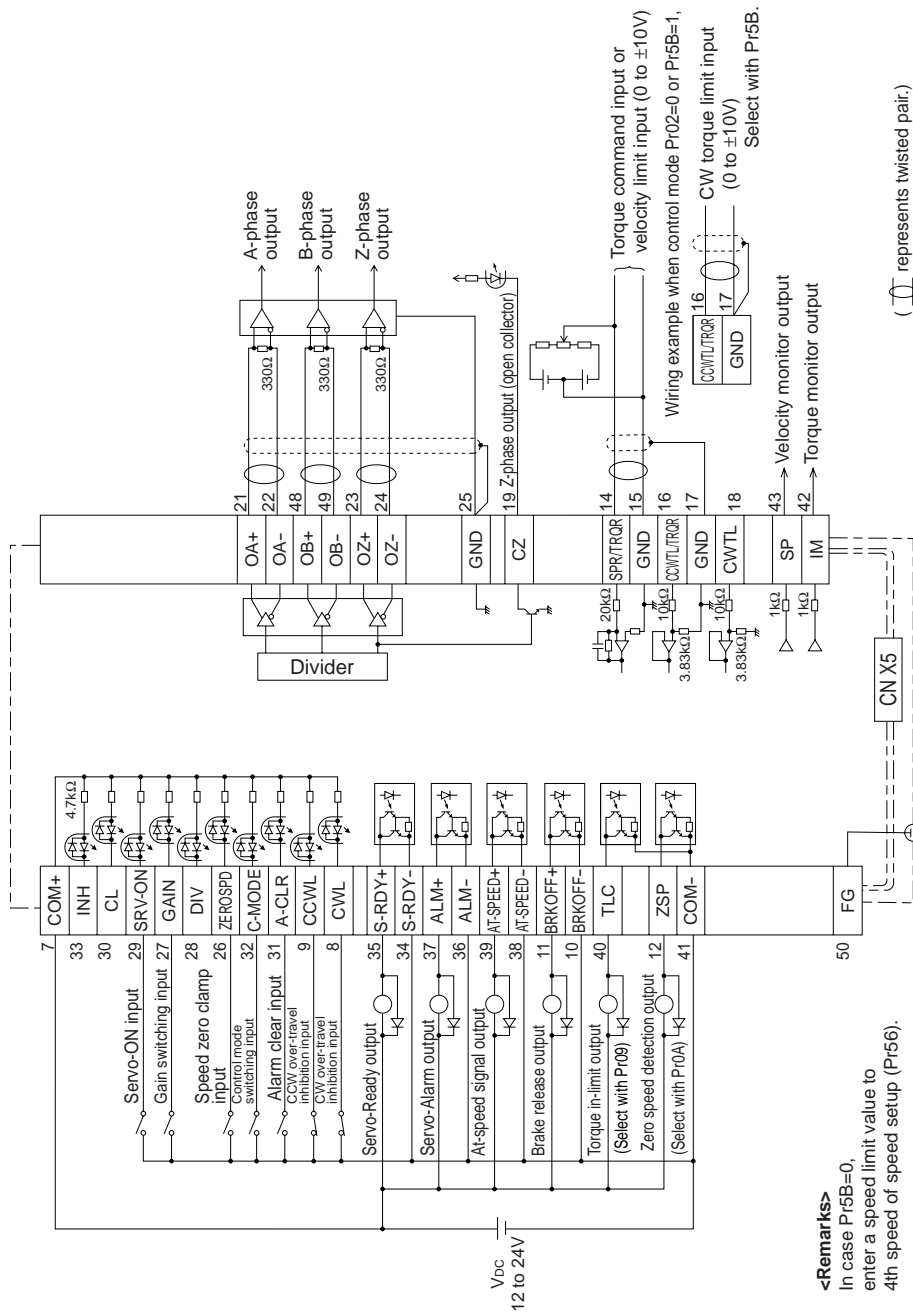

4. Parameter

Outline of Parameter

This driver is equipped with various parameters to set up its characteristics and functions. This section describes the function and purpose of each parameter. Read and comprehend very well so that you can adjust this driver in optimum condition for your running requirements.

How to Set

- You can refer and set up the parameter with either one of the following.
 - front panel of the driver
 - combination of the setup support software, "PANATERM®" (Option, DV0P4460: English/Japanese version) and PC.
 - console (DV0P4420, option)

<Note>

For setup of the parameters on PC screen, refer to the instruction manual of the "PANATERM®".

Setup with the Front Panel

Display LED (6-digit)
 All of LED will flash when error occurs, and switch to error display screen.
 All of LED will flash slowly when warning occurs.

Shifting of the digit for data changing to higher digit. (Valid to the digit whose decimal point flashes.)

Press these to change display and data, select parameters and execute actions. (Change/Selection/Execution is valid to the digit which decimal point flashes.)
 Numerical value increases by pressing \blacktriangle , decreases by pressing \blacktriangledown .

SET Button (valid at any time)
 Press this to switch SELECTION and EXECUTION display.

Mode switching button (valid at SELECTION display)
 Press this to switch 5 kinds of mode.

- 1) Monitor Mode
- 2) Parameter Set up Mode
- 3) EEPROM Write Mode
- 4) Auto-Gain Tuning Mode
- 5) Auxiliary Function Mode

4. Parameter

Outline of PANATERM®

With the PANATERM®, you can execute the followings.

- 1) Setup and storage of parameters, and writing to the memory (EEPROM).
- 2) Monitoring of I/O and pulse input and load factor.
- 3) Display of the present alarm and reference of the error history.
- 4) Data measurement of the wave-form graphic and bringing of the stored data.
- 5) Normal auto-gain tuning
- 6) Frequency characteristic measurement of the machine system.

Setup with the Console

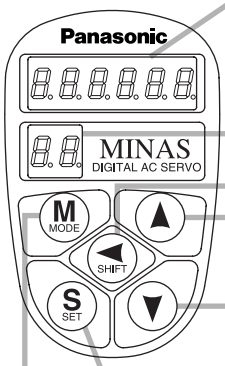

Display LED (6-digit)
All of LED will flash when error occurs, and switch to error display screen.

Displays ID No. (address) of selected driver (in 2 digits).
The value set in Pr00(address) is ID No. Parameter No. is displayed (2 digits) at parameter setup mode.

Press this to shift the digit for data change.

Press these to change data or execute selected action of parameter.
Numerical value increases by pressing ▲, decreases by pressing ▼.

SET Button
Press this to shift each mode which is selected by mode switching button to EXECUTION display.

Mode Switching Button Press this to switch 6 kinds of mode.

1) Monitor mode	4) Normal auto-gain tuning mode
2) Parameter setup mode	5) Auxiliary function mode
3) EEPROM write mode	6) Copy mode

How to Connect

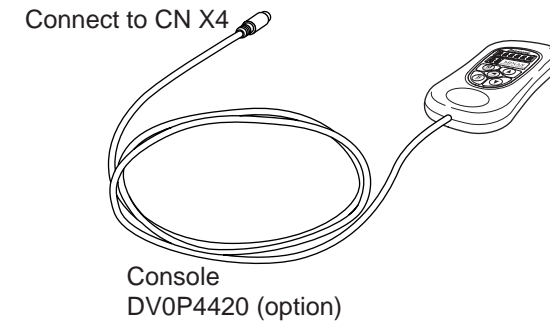
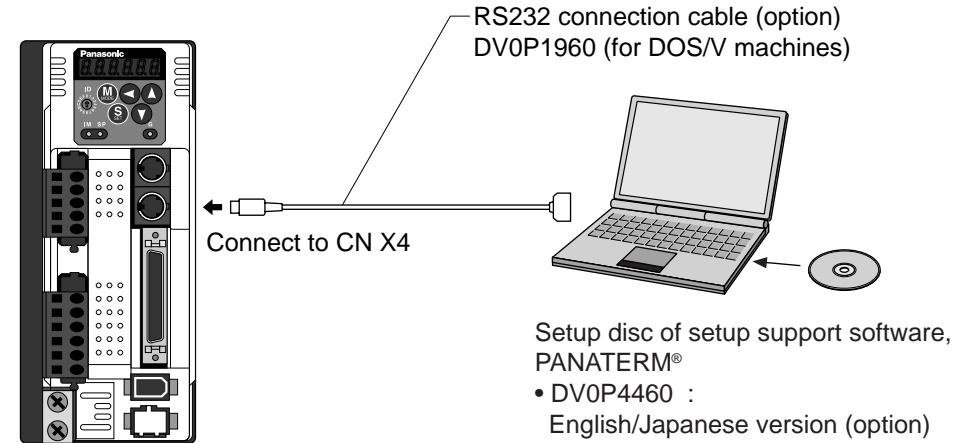

<Remarks>

- Connect the console connector to the connector, CN X4 of the driver securely.
- Do not pull the cable to insert/unplug.

4. Parameter

Composition and List of Parameters

Group	Parameter No. (Pr□□)	Outline
Functional selection	00 to 0F	You can select a control mode, designate I/O signals and set up a baud rate.
Adjustment	10 to 1F, 27 to 2E	You can set up servo gains (1st and 2nd) of position, velocity, integration, etc, and time constants of various filters.
	20 to 26, 2F	Parameters related to Real Time Auto-Gain Tuning. You can set up a mode and select a mechanical stiffness.
	30 to 3F	You can set up parameters related to gain switching(1st ←→ 2nd)
Position (Step) Control	40 to 4F	You can set up an input form, directional selection of command pulses, dividing of encoder output pulse and set up a division multiplier ratio of command pulse.
Velocity Control, Torque Control	50 to 5A, 74 to 77	You can set up an input gain of command pulse, reverse polarity and adjust offset. You can also set up internal speeds (1 to 8th speed), acceleration/ deceleration time.
	5B to 5F	You can set an input gain, reverse polarity and set up a torque limit of torque command.
Sequence	60 to 6F	You can set up detecting conditions of output signals, such as positioning-complete and zero-speed. You can also set up a deceleration/stop action at main power-off, at alarm output and at servo-off, and clear condition of the deviation counter.
	70 to 73	You can set up actions of protective functions.
Full-Closed Control	78 to 7F	You can set up dividing of external scale.

• In this document, following symbols represent each mode.

Symbol	Control mode	Setup value of Pr02	Symbol	Control mode	Setup value of Pr02
P	Position control	0	P/S	Position (1st)/Velocity (2nd) control	3*
S	Velocity control	1	P/T	Position (1st)/Torque (2nd) control	4*
T	Torque control	2	S/T	Velocity (1st)/Torque (2nd) control	5*
F	Full-Closed control	6			

* When you select the combination mode of 3, 4 or 5, you can select either 1st or 2nd with control mode switching input (C-MODE).

when C-MODE is open : 1st mode selection

when C-Mode is closed: 2nd mode selection

Do not enter the command 10ms before/after the switching.

Parameters for Functional Selection

Parameter No. (Pr□□)	Set up of parameter	Range	Default	Unit	Related control mode
00*1	Address of axis	0 to 15	1	–	all
01*1	Initial display of LED	0 to 17	1	–	all
02*1	Setup of control mode	0 to 6	1	–	all
03	Selection of torque limit	0 to 3	1	–	P, S, F
04*1	Setup of over-travel inhibit input	0 to 2	1	–	all
05	Switching of Internal/External speed setup	0 to 3	0	–	S
06	Selection of ZEROSPD input	0 to 2	0	–	S, T
07	Selection of speed monitor (SP)	0 to 9	3	–	all
08	Selection of torque monitor (IM)	0 to 12	0	–	all
09	Selection of TLO output	0 to 8	0	–	all
0A	Selection of ZSP output	0 to 8	1	–	all
0B*1	Setup of absolute encoder	0 to 2	1	–	all
0C*1	Baud rate setup of RS232	0 to 5	2	–	all
0D*1	Baud rate setup of RS485	0 to 5	2	–	all
0E*1	Setup of front panel lock	0 to 1	0	–	all
0F	(For manufacturer's use)	–	–	–	–

Parameters for Adjustment of Time Constant for Gains and Filters

Parameter No. (Pr□□)	Set up of parameter	Range	Default		Unit	Related control mode
			A to C-frame	D to F-frame		
10	1st gain of position loop	0 to 3000	<63>	<32>	1/s	P, F
11	1st gain of velocity loop	1 to 3500	<35>	<18>	Hz	all
12	1st time constant of velocity loop integration	1 to 1000	<16>	<31>	ms	all
13	1st filter of velocity detection	0 to 5	<0>		–	all
14	1st time constant of torque filter	0 to 2500	<65>	<126>	0.01ms	all
15	Velocity feed forward	–2000 to 2000	<300>		0.1%	P, F
16	Time constant of feed forward filter	0 to 6400	<50>		0.01ms	P, F
17	(For manufacturer's use)	–	–	–	–	–

<Notes>

- For parameters with suffix of "*1", change will be validated after the reset of the control power.
- For parameters which default values are parenthesized by "< >", default value varies automatically by the real-time auto-gain tuning function. Set up Pr21 (Setup of Real-time auto-gain tuning mode) to 0 (invalid) when you want to adjust manually.

* In this documentation, each mode is represented by the following symbols

P : Position control, S : Velocity control, T : Torque control, F : Full-closed control, P/S : Position (1st)/Velocity (2nd) control, P/T : Position (1st)/Torque (2nd) control, S/T : Velocity (1st)/Torque (2nd) control.

4. Parameter

Parameters for Adjustment of Time Constant for Gains and Filters

Parameter No. (Pr□□)	Set up of parameter	Range	Default		Unit	Related control mode
			A to C-frame	D to F-frame		
18	2nd gain of position loop	0 to 3000	<73>	<38>	1/s	P, F
19	2nd gain of velocity loop	1 to 3500	<35>	<18>	Hz	all
1A	2nd Time constant of velocity loop integration	1 to 1000	<1000>		ms	all
1B	2nd filter of velocity detection	0 to 5	<0>		–	all
1C	2nd torque filter time constant	0 to 2500	<65>	<126>	0.01ms	all
1D	1st notch frequency	100 to 1500	1500		Hz	all
1E	Selection of 1st notch width	0 to 4	2		–	all
1F	(For manufacturer's use)	–	–		–	–
27	Setup of instantaneous velocity observer	0 to 1	<0>		–	P, S
28	2nd notch frequency	100 to 1500	1500		Hz	all
29	Selection of 2nd notch width	0 to 4	2		–	all
2A	Selection of 2nd notch depth	0 to 99	0		–	all
2B	1st damping frequency	0 to 2000	0		0.1Hz	P, F
2C	Setup of 1st damping filter	–200 to 2000	0		–	P, F
2D	2nd damping frequency	0 to 2000	0		0.1Hz	P, F
2E	Setup of 2nd damping filter	–200 to 2000	0		–	P, F

Parameters for Auto-Gain Tuning

Parameter No. (Pr□□)	Set up of parameter	Range	Default		Unit	Related control mode
			A to C-frame	D to F-frame		
20	Inertia ratio	0 to 10000	<250>		%	all
21	Setup of real-time auto-gain tuning mode	0 to 7	1		–	all
22	Mechanical stiffness at real-time auto-gain tuning	0 to 15	4	1	–	all
23	Setup of adaptive filter mode	0 to 2	1		–	P, S, F
24	Selection of damping filter switching	0 to 2	0		–	P, F
25	Setup of action at normal mode auto-gain tuning	0 to 7	0		–	all
26	Setup of software limit	0 to 1000	10		0.1rev	P, F
2F*2	Adaptive filter frequency	0 to 64	0		–	P, S, F

*2 this parameter will be automatically set up when the adaptive filter is validated (Pr23, "Setup of adaptive filter mode" is "1", and you cannot set this up at your discretion. Set up Pr23, "Setup of adaptive filter mode" to "0" (invalid) to clear this parameter.

* In this documentation, each mode is represented by the following symbols

P : Position control, S : Velocity control, T : Torque control, F : Full-closed control,
P/S : Position (1st)/Velocity (2nd) control, P/T : Position (1st)/Torque (2nd) control,
S/T : Velocity (1st)/Torque (2nd) control.

Parameters for Adjustment (2nd Gain Switching Function)

Parameter No. (Pr□□)	Set up of parameter	Range	Default	Unit	Related control mode
30	Setup of 2nd gain	0 to 1	<1>	–	all
31	1st mode of control switching	0 to 10	<0>	–	all
32	1st delay time of control switching	0 to 10000	<30>	166μs	all
33	1st level of control switching	0 to 20000	<50>	–	all
34	1st hysteresis of control switching	0 to 20000	<33>	–	all
35	Time for position gain switching	0 to 10000	<20>	(1+Setup value) x 166μs	P, F
36	2nd mode of control switching	0 to 5	<0>	–	S, T
37	2nd delay time of control switching	0 to 10000	0	166μs	S, T
38	2nd level of control switching	0 to 20000	0	–	S, T
39	2nd hysteresis of control switching	0 to 20000	0	–	S, T
3A	(For manufacturer's use)	–	–	–	–
3B	(For manufacturer's use)	–	–	–	–
3C	(For manufacturer's use)	–	–	–	–
3D	Setup of JOG speed	0 to 500	300	r/min	all
3E	(For manufacturer's use)	–	–	–	–
3F	(For manufacturer's use)	–	–	–	–

Parameters for Position Control

Parameter No. (Pr□□)	Set up of parameter	Range	Default	Unit	Related control mode
40*1	Selection of command pulse input	0 to 1	0	–	P, F
41*1	setup of rotational direction of command pulse	0 to 1	0	–	P, F
42*1	setup of command pulse input mode	0 to 3	1	–	P, F
43	Canceling of command pulse prohibition input	0 to 1	1	–	P, F
44*1	Numerator of pulse output division	1 to 32767	2500	–	all
45*1	Denominator of pulse output division	0 to 32767	0	–	all
46*1	Logic reversal of pulse output	0 to 3	0	–	all
47*1	Setup of Z-phase of external scale	0 to 32767	0	–	F

<Notes>

- For parameters with suffix of "*1", change will be validated after the reset of the control power.
- For parameters which default values are parenthesized by "< >", default value varies automatically by the real-time auto-gain tuning function. Set up Pr21 (Setup of Real-time auto-gain tuning mode) to 0 (invalid) when you want to adjust manually.

4. Parameter

Parameter No. (Pr□□)	Set up of parameter	Range	Default	Unit	Related control mode
48	1st numerator of electronic gear	0 to 10000	0	–	P, F
49	2nd numerator of electronic gear	0 to 10000	0	–	P, F
4A	Multiplier for numerator of electronic gear	0 to 17	0	–	P, F
4B	Denominator of electronic gear	1 to 10000	10000	–	P, F
4C	Setup of smoothing filter for primary delay	0 to 7	1	–	P, F
4D*1	Setup of FIR smoothing	0 to 31	0	–	P, F
4E	Counter clear input mode	0 to 2	1	–	P, F
4F	(For manufacturer's use)	–	–	–	–

Parameters for Velocity/Torque control

Parameter No. (Pr□□)	Set up of parameter	Range	Default	Unit	Related control mode
50	Input gain of speed command	10 to 2000	500	(r/min)/V	S, T
51	Input reversal of speed command	0 to 1	1	–	S
52	Offset of speed command	–2047 to 2047	0	0.3mV	S, T
53	1st speed of speed setup	–20000 to 20000	0	r/min	S
54	2nd speed of speed setup	–20000 to 20000	0	r/min	S
55	3rd speed of speed setup	–20000 to 20000	0	r/min	S
56	4th speed of speed setup	–20000 to 20000	0	r/min	S, T
74	5th speed of speed setup	–20000 to 20000	0	r/min	S
75	6th speed of speed setup	–20000 to 20000	0	r/min	S
76	7th speed of speed setup	–20000 to 20000	0	r/min	S
77	8th speed of speed setup	–20000 to 20000	0	r/min	S
57	Setup of speed command filter	0 to 6400	0	0.01ms	S, T
58	Setup of acceleration time	0 to 5000	0	$\frac{2\text{ms}}{(1000\text{r/min})}$	S
59	Setup of deceleration time	0 to 5000	0	$\frac{2\text{ms}}{(1000\text{r/min})}$	S
5A	Setup of sigmoid acceleration/deceleration time	0 to 500	0	2ms	S
5B	Selection of torque command	0 to 1	0	–	T
5C	Input gain of torque command	10 to 100	30	$\frac{0.1\text{V}}{\text{rated torque}}$	T
5D	Input reversal of torque command	0 to 1	0	–	T
5E	Setup of 1st torque limit	0 to 500	<500>*3	%	all
5F	Setup of 2nd torque limit	0 to 500	<500>*3	%	P, S, F

* In this documentation, each mode is represented by the following symbols

P : Position control, S : Velocity control, T : Torque control, F : Full-closed control,
 P/S : Position (1st)/Velocity (2nd) control, P/T : Position (1st)/Torque (2nd) control,
 S/T : Velocity (1st)/Torque (2nd) control.

Parameters for Sequence

Parameter No. (Pr□□)	Set up of parameter	Range	Default	Unit	Related control mode
60	In-position (positioning complete) range	0 to 32767	131	Pulse	P, F
61	Zero speed	10 to 20000	50	r/min	all
62	At-speed (arrived speed)	10 to 20000	1000	r/min	S, T
63	Setup of in-position output	0 to 3	0	–	P, F
64	(For manufacturer's use)	–	–	–	–
65	Selection of LV-trip at main power off	0 to 1	1	–	all
66*1	Sequence at run-prohibition	0 to 2	0	–	all
67	Sequence at main power off	0 to 9	0	–	all
68	Sequence at alarm	0 to 3	0	–	all
69	Sequence at servo-off	0 to 9	0	–	all
6A	Setup of mechanical brake action at stall	0 to 100	0	2ms	all
6B	Setup of mechanical brake action in motion	0 to 100	0	2ms	all
6C*1	Selection of external regenerative resistor	0 to 3	<small>A, B-frame:3, C, D, E-frame:0</small>	–	all
6D*1	Detection time of main power shut-off	35 to 1000	35	2ms	all
6E	Setup to torque at emergency stop	0 to 500	0	–	all
6F	(For manufacturer's use)	–	–	–	–
70	Excess setup of positional deviation	0 to 32767	25000	256Pulse	P, F
71	Excess setup of analog input	0 to 100	0	0.1V	S, T
72	Setup of over-load level	0 to 500	0	%	all
73	Setup of over-speed level	0 to 20000	0	r/min	all

Parameters for Full-Closed Control

Parameter No. (Pr□□)	Set up of parameter	Range	Default	Unit	Related control mode
78*1	Numerator of external scale division	0 to 32767	0	–	F
79*1	Numerator multiplier of external scale division	0 to 17	0	–	F
7A*1	Denominator of external scale division	1 to 32767	10000	–	F
7B*1	Excess setup of hybrid deviation	1 to 10000	100	<small>16 X external scale pulses</small>	F
7C*1	Reversal of direction of external scale	0 to 1	0	–	F
7D	(For manufacturer's use)	–	–	–	–
7E	(For manufacturer's use)	–	–	–	–
7F	(For manufacturer's use)	–	–	–	–

<Notes>

• For parameters with suffix of "*1", change will be validated after the reset of the control power.

*3 Defaults of Pr5E and Pr5F vary depending on the combination of the driver and the motor.

5. Protective Functions

Protective Function (What Is Error Code ?)

- Various protective functions are equipped in the driver. When these are triggered, the motor will stall due to error, the driver will turn the Servo-Alarm output (ALM) to off (open).
- Error status and their measures
 - During the error status, the error code No. will be displayed on the front panel LED, and you cannot turn Servo-ON.
 - You can clear the error status by turning on the alarm clear input (A-CLR) for 120ms or longer.
 - When overload protection is triggered, you can clear it by turning on the alarm clear signal (A-CLR) 10 sec or longer after the error occurs. You can clear the time characteristics by turning off the connection between L1C and L2C or r and t of the control power supply of the driver.
 - You can clear the above error by operating the front panel keys.
 - You can also clear the above error by operating the "PANATERM[®]".

<Remarks>

- When the protective function with a prefix of "*" in the protective function table is triggered, you cannot clear with alarm clear input (A-CLR). For resumption, shut off the power to remove the cause of the error and re-enter the power.
- Following errors will not be stored in the error history.
 - Control power supply under-voltage protection (Error code No. 11)
 - Main power supply under-voltage protection (Error code No. 13)
 - EEPROM parameter error protection (Error code No. 36)
 - EEPROM check code error protection (Error code No. 37)
 - Over-travel prohibition input protection (Error code No. 38)
 - Motor self-recognition error protection (Error code No. 95)

Error code No.	Protective function	Error code No.	Protective function
11	Control power supply under- voltage protection	39	Analog input excess protection
12	Over-voltage protection	40	Absolute system down error protection
13	Main power supply under-voltage protection	41	* Absolute counter over error protection
14	* Over-current protection	42	Absolute over-speed error protection
15	* Over-heat protection	44	* Absolute single turn counter error protection
16	Over-load protection	45	* Absolute multi-turn counter error protection
18	* Over-regeneration load protection	47	Absolute status error protection
21	* Encoder communication error protection	48	* Encoder Z-phase error protection
23	* Encoder communication data error protection	49	* Encoder CS signal error protection
24	Position deviation excess protection	50	* External scale status 0 error protection
25	* Hybrid deviation excess error protection	51	* External scale status 1 error protection
26	Over-speed protection	52	* External scale status 2 error protection
27	Electronic gear error protection	53	* External scale status 3 error protection
28	* External scale communication data error protection	54	* External scale status 4 error protection
29	Deviation counter overflow protection	55	* External scale status 5 error protection
34	Software limit protection	65	CCWTL input excess protection
35	* External scale communication error protection	66	CWTL input excess protection
36	* EEPROM parameter error protection	95	* Motor automatic recognition error protection
37	* EEPROM check code error protection	Other No.	* Other error
38	Over-travel inhibit input protection		

6. Maintenance and Inspections

- Routine maintenance and inspection of the driver and motor are essential for the proper and safe operation.

Notes on Maintenance and Inspection

- 1) Turn on and turn off should be done by operators or inspectors themselves.
- 2) Internal circuit of the driver is kept charged with high voltage for a while even after power-off. Turn off the power and allow 15 minutes or longer after LED display of the front panel has gone off, before performing maintenance and inspection.
- 3) Disconnect all of the connection to the driver when performing megger test (Insulation resistance measurement) to the driver, otherwise it could result in breakdown of the driver.

Inspection Items and Cycles

General and normal running condition

Ambient conditions : 30°C (annual average), load factor of 80% or lower, operating hours of 20 hours or less per day.

Perform the daily and periodical inspection as per the items below.

Type	Cycles	Items to be inspected
Daily inspection	Daily	<ul style="list-style-type: none"> • Ambient temperature, humidity, speck, dust or foreign object • Abnormal vibration and noise • Main circuit voltage • Odor • Lint or other particles at air holes • Cleanness at front portion of the driver and connector • Damage of the cables • Loose connection or misalignment between the motor and machine or equipment • Pinching of foreign object at the load
Periodical inspection	Annual	<ul style="list-style-type: none"> • Loose tightening • Trace of overheat • Damage of the terminals

<Notes>

Inspection cycle may change when the running conditions of the above change.

Guideline for Parts Replacement

Use the table below for a reference. Parts replacement cycle varies depending on the actual operating conditions. Defective parts should be replaced or repaired when any error have occurred.

 Prohibited	Disassembling for inspection and repair should be carried out only by authorized dealers or service company.
--	---

Product	Component	Standard replacement cycles (hour)	Note
Driver	Smoothing condenser	Approx. 5 years	These hours or cycles are reference. When you experience any error, replacement is required even before this standard replacement cycle.
	Cooling fan	2 to 3 years (10,000 to 30,000 hours)	
	Aluminum electrolytic capacitor (on PCB)	Approx. 5 years	
	Rush current preventive relay	Approx. 100,000 times (depending on working condition)	
	Rush current preventive resistor	Approx. 20,000 times (depending on working condition)	
Motor	Bearing	3 to 5 years (20,000 to 30,000 hours)	
	Oil seal	5000 hours	
	Encoder	3 to 5 years (20,000 to 30,000 hours)	
	Battery for absolute encoder	Life time varies depending on working conditions. Refer to the instruction manual attached to the battery for absolute encoder.	
Motor with gear reducer	Gear reducer	10,000 hours	

7. Conformity to EC Directives and UL Standards

EC Directives

The EC Directives apply to all such electronic products as those having specific functions and have been exported to EU and directly sold to general consumers. Those products are required to conform to the EU unified standards and to furnish the CE marking on the products.

However, our AC servos meet the relevant EC Directives for Low Voltage Equipment so that the machine or equipment comprising our AC servos can meet EC Directives.

EMC Directives

MINAS Servo System conforms to relevant standard under EMC Directives setting up certain model (condition) with certain locating distance and wiring of the servo motor and the driver. And actual working condition often differs from this model condition especially in wiring and grounding. Therefore, in order for the machine to conform to the EMC Directives, especially for noise emission and noise terminal voltage, it is necessary to examine the machine incorporating our servos.

Conformed Standards

Subject	Conformed Standard		
Motor	IEC60034-1 IEC60034-5 UL1004 CSA22.2 No.100		Conforms to Low-Voltage Directives
	EN50178	UL508C	
Motor/ Motor and driver	EN55011	Radio Disturbance Characteristics of Industrial, Scientific and Medical (ISM) Radio-Frequency Equipment	Standards referenced by EMC Directives
	EN61000-6-2	Immunity for Industrial Environments	
	IEC61000-4-2	Electrostatic Discharge Immunity Test	
	IEC61000-4-3	Radio Frequency Electromagnetic Field Immunity Test	
	IEC61000-4-4	Electric High-Speed Transition Phenomenon/Burst Immunity Test	
	IEC61000-4-5	Lightening Surge Immunity Test	
	IEC61000-4-6	High Frequency Conduction Immunity Test	
	IEC61000-4-11	Instantaneous Outage Immunity Test	

IEC : International Electrotechnical commission

E N : Europaischen Normen

EMC : Electromagnetic Compatibility

UL : Underwriters Laboratories

CSA : Canadian Standards Association

<Precautions in using options>

Use options correctly after reading operation manuals of the options to better understand the precautions.

Take care not to apply excessive stress to each optional part.

Composition of Peripheral Equipments

Installation Environment

Use the servo driver in the environment of Pollution Degree 1 or 2 prescribed in IEC-60664-1 (e.g. Install the driver in control panel with IP54 protection structure.)

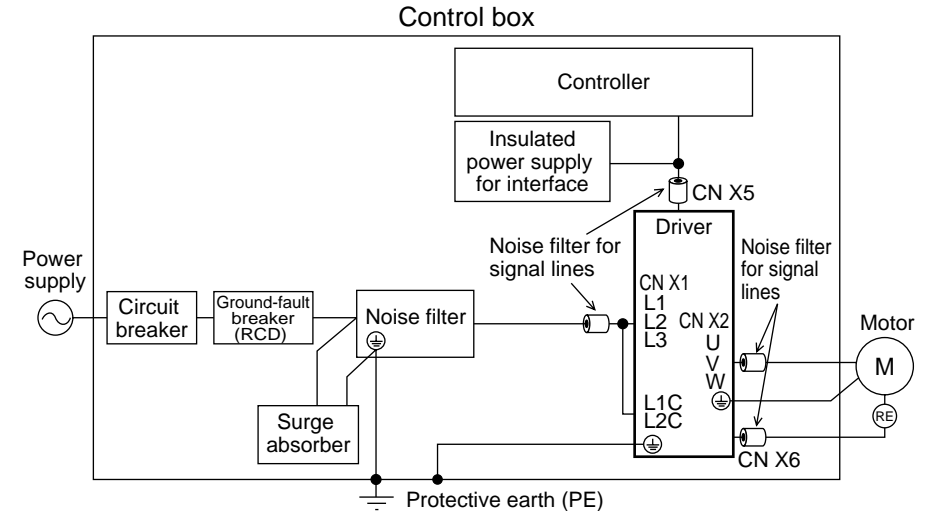

Power Supply

100V type : Single phase, (A, B and C-frame)	100V	+10% -15%	to	115V	+10% -15%	50/60Hz
200V type : Single phase, (B, C-frame)	200V	+10% -15%	to	240V	+10% -15%	50/60Hz
200V type : Single/3-phase, (C, D-frame)	200V	+10% -15%	to	240V	+10% -15%	50/60Hz
200V type : 3-phase, (E, F-frame)	200V	+10% -15%	to	230V	+10% -15%	50/60Hz

(1) This product is designed to be used at over-voltage category (Installation category) II of EN 50178:1997. If you want to use this product un over-voltage category (Installation category) III, install a surge absorber which complies with EN61634-11:2002 or other relevant standards at the power input portion.

(2) Use an insulated power supply of DC12 to 24V which has CE marking or complies with EN60950

Circuit Breaker

Install a circuit breaker which complies with IEC Standards and UL recognizes (Listed and Ⓢ marked) between power supply and noise filter.

7. Conformity to EC Directives and UL Standards

Noise Filter

When you install one noise filter at the power supply for multi-axes application, contact to a manufacture of the noise filter.

Option part No.	Voltage specifications for driver	Manufacturer's part No.	Applicable driver (frame)	Manufacturer
DV0P4170	Single phase 100V/200V	SUP-EK5-ER-6	A and B-frame	Okaya Electric Ind.

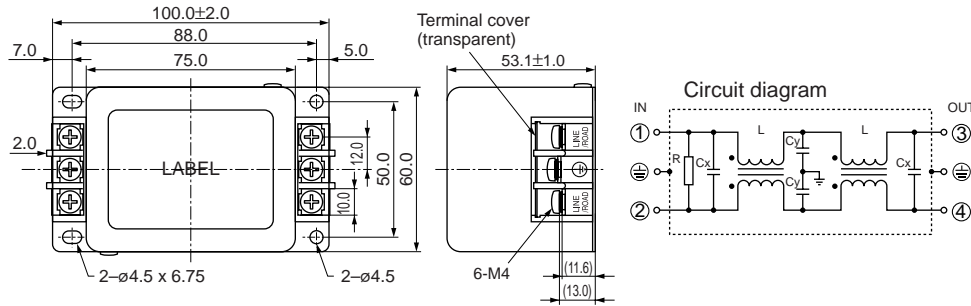

Option part No.	Voltage specifications for driver	Manufacturer's part No.	Applicable driver (frame)	Manufacturer
DV0P4180	3-phase 200V	3SUP-HQ10-ER-6	C-frame	Okaya Electric Ind.
DV0P4220		3SUP-HU30-ER-6	D and E-frame	

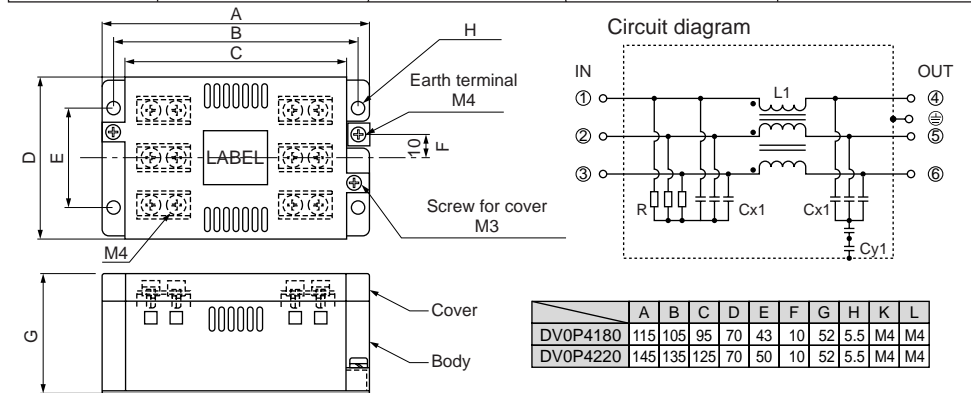

Option part No.	Voltage specifications for driver	Manufacturer's part No.	Applicable driver (frame)	Manufacturer
DV0P3410	Three-phase 200V	3SUP-HL50-ER-6B	F-frame	Okaya Electric Ind.

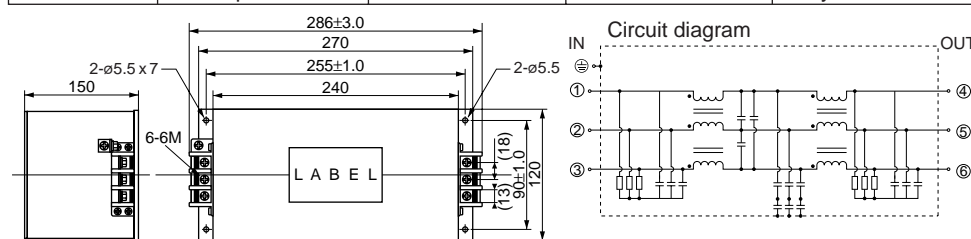

Surge Absorber

Provide a surge absorber for the primary side of noise filter.

<Remarks>

Take off the surge absorber when you execute a dielectric test to the machine or equipment, or it may damage the surge absorber.

Option part No.	Voltage specifications for driver	Manufacturer's part No.	Manufacturer
DV0P1450	3-phase 200V	R . A .V-781BXZ-4	Okaya Electric Ind.

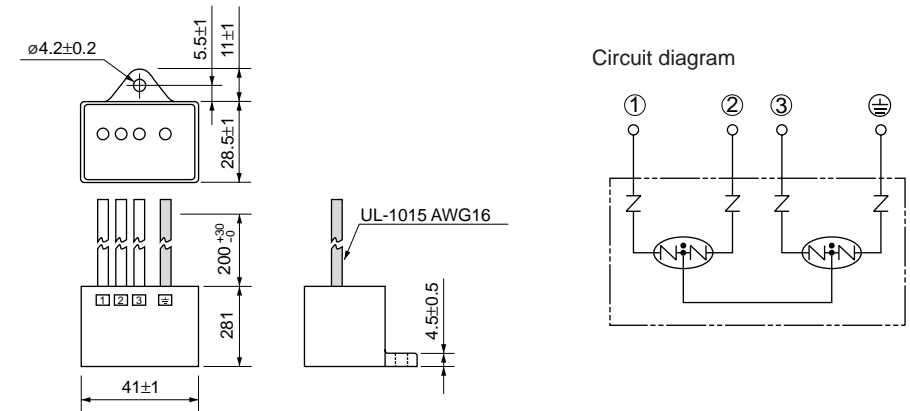

Option part No.	Voltage specifications for driver	Manufacturer's part No.	Manufacturer
DV0P4190	Single phase 100/200V	R . A .V-781BWZ-4	Okaya Electric Ind.

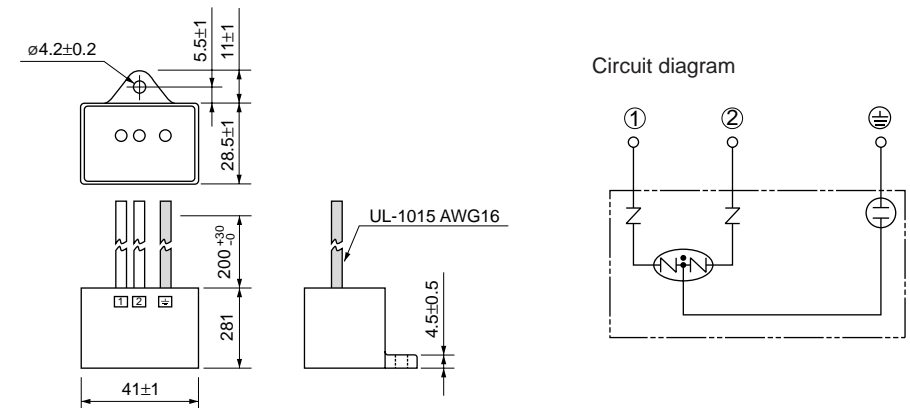

7. Conformity to EC Directives and UL Standards

Noise Filter for Signal Lines *

Install noise filters for signal lines to all cables (power cable, motor cable, encoder cable and interface cable)

* In case of D-frame, install 3 noise filters at power line.

Option part No.	DV0P1460
Manufacturer's part No.	ZCAT3035-1330
Manufacturer	TDK Corp.

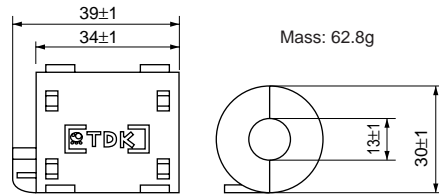

<Caution> Fix the signal line noise filter in place to eliminate excessive stress to the cables.

Ground-Fault Breaker

Install a type B ground fault breaker (RCD) at primary side of the power supply.

Grounding

- (1) Connect the protective earth terminal (⊕) of the driver and the protective earth terminal (PE) of the control box without fail to prevent electrical shocks.
- (2) Do not make a joint connection to the protective earth terminals (⊕). 2 terminals are provided for protective earth.

<Note>

For driver and applicable peripheral equipments, refer to P.B14 "Driver and List of Applicable Peripheral Equipments" .

Conformity to UL Standards

Observe the following conditions of (1) and (2) to make the system conform to UL508C (File No. E164620).

- (1) Use the driver in an environment of Pollution Degree 2 or 1 prescribed in IEC60664-1. (e.g. Install in the control box with IP54 enclosure.)
- (2) Install a circuit breaker or fuse which are UL recognized (Listed Ⓢ marked) between the power supply and the noise filter without fail.

For the rated current of the circuit breaker or fuse, refer to P.32, "Driver and List of Applicable Peripheral Equipments" of Preparation.

Use a copper cable with temperature rating of 60°C or higher.

Tightening torque of more than the max. values (M4:1.2N·m, M5: 2.0N·m) may break the terminal block.

- (3) Over-load protection level

Over-load protective function will be activated when the effective current exceeds 115% or more than the rated current based on the time characteristics. Confirm that the effective current of the driver does not exceed the rated current. Set up the peak permissible current with Pr5E (Setup of 1st torque limit) and Pr5F (Setup 2nd torque limit).

8. Built-in Holding Brake

In the applications where the motor drives the vertical axis, this brake would be used to hold and prevent the work (moving load) from falling by gravity while the power to the servo is shut off.

Use this built-in brake for "Holding" purpose only, that is to hold the stalling status. Never use this for "Brake" purpose to stop the load in motion.

Output Timing of BRK-OFF Signal

- For the brake release timing at power-on, or braking timing at Servo-OFF/Servo-Alarm while the motor is in motion, refer to the technical reference. (DV0P4210)
- With the parameter, Pr6B (Setup of mechanical brake action while the motor is in motion), you can set up a time between when the motor enters to a free-run from energized status and when BRK-OFF signal turns off (brake will be engaged), when the Servo-OFF or alarm occurs while the motor is in motion.

<Notes>

1. The lining sound of the brake (chattering and etc.) might be generated while running the motor with built-in brake, however this does not affect any functionality.
2. Magnetic flux might be generated through the motor shaft while the brake coil is energized (brake is open). Pay an extra attention when magnetic sensors are used nearby the motor.

Specifications of Built-in Holding Brake

Motor series	Motor output	Static friction torque N·m	Rotor inertia x 10 ⁻⁴ kg·m ²	Engaging time ms	Releasing time ms*	Exciting current DC A (at cool-off)	Releasing voltage	Permissible work (J) per one braking	Permissible total work x 10 ³ J
MSMD MAMA	50W, 100W	0.29 or more	0.002	35 or less	10 or less	0.25	DC2V or more	39.2	4.9
	200W, 400W	1.27 or more	0.018	50 or less		0.30		137	44.1
	750W	2.45 or more	0.075	70 or less		0.35		196	147
MQMA	100W	0.29 or more	0.03	50 or less	15 or less	0.29	DC1V or more	137	44.1
	200W, 400W	1.27 or more	0.09	60 or less		0.41		196	147
MSMA	1.0kW	4.9 or more	0.25	50 or less	15 (100) or less	0.74	DC2V or more	392	196
	1.5kW, 2.0kW	7.8 or more	0.33			0.81			490
	3.0kW	11.8 or more		110 or less	50 (130) or less	0.90		1470	2156
	4.0kW, 5.0kW	16.1 or more	1.35						

(Continues to next page)

8. Built-in Holding Brake

Motor series	Motor output	Static friction torque N·m	Rotor inertia x 10 ⁻⁴ kg·m ²	Engaging time ms	Releasing time ms*	Exciting current DC A (at cool-off)	Releasing voltage	Permissible work (J) per one braking	Permissible total work x 10 ³ J
MDMA	1.0kW	4.9 or more	1.35	80 or less	70 (200) or less	0.59	DC2V or more	588	780
	1.5kW, 2.0kW	13.7 or more		100 or less	50 (130) or less	0.79		1176	1470
	3.0kW	16.1 or more		110 or less		0.90		1470	2156
	4.0kW	21.5 or more	4.25	90 or less	35 (150) or less	1.10		1078	2450
	5.0kW	24.5 or more	4.7	80 or less	25 (200) or less	1.30		1372	2940
MHMA	500W, 1.0kW	4.9 or more	1.35		70 (200) or less	0.59		588	784
	1.5kW	13.7 or more		100 or less	50 (130) or less	0.79		1176	1470
	2.0kW to 5.0kW	24.5 or more	4.7		25 (200) or less	1.30		1372	2940
MFMA	400W	4.9 or more	1.35	80 or less	70 (200) or less	0.59		588	784
	1.5kW	7.8 or more	4.7		35 (150) or less	0.83		1372	2940
	2.5kW	21.6 or more	8.75	150 or less	100 (450) or less	0.75	1470	1470	
	4.5kW	31.4 or more					2156		
MGMA	900W	13.7 or more	1.35	100 or less	50 (130) or less	0.79	1176	1470	
	2.0kW	24.5 or more	4.7	80 or less	25 (200) or less	1.3	1372	2940	
	3.0kW, 4.5kW	58.8 or more		150 or less	50 (130) or less	1.4			

- Excitation voltage is DC24V±10%.
 - Values represent the ones with DC-cutoff using a surge absorber for holding brake. Values in () represent those measured by using a diode (V03C by Renesas Technology Corp.).
 - Above values (except static friction torque, releasing voltage and excitation current) represent typical values.
 - Backlash of the built-in holding brake is kept ±1° or smaller at ex-factory point.
 - Permissible angular acceleration : 30000rad/s² for MAMA series
10000rad/s² for MSMD, MQMA, MSMA MDMA, MHMA MFMA and MGMA series
 - Service life of the number of acceleration/deceleration with the above permissible angular acceleration is more than 10 million times.
- (Life end is defined as when the brake backlash drastically changes.)

9. Dynamic Brake

This driver is equipped with a dynamic brake for emergency stop. Pay a special attention to the followings.

<Caution>

1. Dynamic brake is only for emergency stop.

Do not start/stop the motor by turning on/off the Servo-ON signal (SRV-ON). Or it may damage the dynamic brake circuit of the driver.

The motor becomes a dynamo when driven externally, and shorting current runs while this dynamic brake is activated and might cause smoking or fire.

2. Dynamic brake is a short-duration rating, and designed for only emergency stop. Allow approx. 3 minutes pause when the dynamic brake is activated during high-speed running.

• You can activate the dynamic brake in the following cases.

- 1) when the main power is turned off
- 2) at Servo-OFF
- 3) when one of the protective function is activated.
- 4) when over-travel inhibit input (CWL, CCWL) of CN X5 is activated

In the above cases from 1) to 4), you can select either activation of the dynamic brake or making the motor free-run during deceleration or after the stop, with parameter.

Note that when the control power is off, the dynamic brake will be kept activated.

10. Check of the Combination of the Driver and the Motor

This drive is designed to be used in a combination with the motor which are specified by us. Check the series name of the motor, rated output torque, voltage specifications and encoder specifications.

Incremental Specifications, 2500P/r

<Remarks> Do not use in other combinations than those listed below.

Power supply	Applicable motor			Applicable driver		
	Motor series	Rated rotational speed	Model	Rated output	Model	Frame
Single phase, 200V	MAMA Ultra low inertia	5000r/min	MAMA012P1*	100W	MADDT1207	A-frame
			MAMA022P1*	200W	MBDDT2210	B-frame
			MAMA042P1*	400W	MCDDT3520	C-frame
			MAMA082P1*	750W	MDDDT5540	D-frame
3-phase, 200V	MQMA Low inertia	3000r/min	MQMA011P1*	100W	MADDT1107	A-frame
			MQMA021P1*	200W	MBDDT2110	B-frame
			MQMA041P1*	400W	MCDDT3120	C-frame
			MQMA012P1*	100W	MADDT1205	A-frame
Single phase, 100V	MSMD Low inertia	3000r/min	MSMD022P1*	200W	MADDT1207	A-frame
			MSMD042P1*	400W	MBDDT2210	B-frame
			MSMD011P1*	100W	MADDT1107	A-frame
			MSMD021P1*	200W	MBDDT2110	B-frame
Single phase, 200V	MSMA Low inertia	3000r/min	MSMD041P1*	400W	MCDDT3120	C-frame
			MSMD5AZP1*	50W	MADDT1205	A-frame
			MSMD012P1*	100W	MADDT1207	A-frame
			MSMD022P1*	200W	MADDT1207	A-frame
Single/3-phase, 200V	MSMA Low inertia	3000r/min	MSMD042P1*	400W	MBDDT2210	B-frame
			MSMD082P1*	750W	MCDDT3520	C-frame
			MSMA102P1*	1.0kW	MDDDT5540	D-frame
			MSMA152P1*	1.5kW	MDDDT5540	D-frame
3-phase, 200V	MDMA Middle inertia	2000r/min	MSMA202P1*	2.0kW	MEDDT7364	E-frame
			MSMA302P1*	3.0kW	MFDDTA390	F-frame
			MSMA402P1*	4.0kW	MFDDTB3A2	F-frame
			MSMA502P1*	5.0kW	MFDDTB3A2	F-frame
Single/3-phase, 200V	MHMA High inertia	2000r/min	MDMA102P1*	1.0kW	MDDDT3530	D-frame
			MDMA152P1*	1.5kW	MDDDT5540	D-frame
			MDMA202P1*	2.0kW	MEDDT7364	E-frame
			MDMA302P1*	3.0kW	MFDDTA390	F-frame
Single/3-phase, 200V	MHMA High inertia	2000r/min	MDMA402P1*	4.0kW	MFDDTA390	F-frame
			MDMA502P1*	5.0kW	MFDDTB3A2	F-frame
			MHMA052P1*	500W	MCDDT3520	C-frame
			MHMA102P1*	1.0kW	MDDDT3530	D-frame
3-phase, 200V	MHMA High inertia	2000r/min	MHMA152P1*	1.5kW	MDDDT5540	D-frame
			MHMA202P1*	2.0kW	MEDDT7364	E-frame
			MHMA302P1*	3.0kW	MFDDTA390	F-frame
			MHMA402P1*	4.0kW	MFDDTA390	F-frame
3-phase, 200V	MHMA High inertia	2000r/min	MHMA502P1*	5.0kW	MFDDTB3A2	F-frame
			MHMA502P1*	5.0kW	MFDDTB3A2	F-frame

Power supply	Applicable motor			Applicable driver		
	Motor series	Rated rotational speed	Model	Rated output	Model	Frame
Single/3-phase, 200V	MFMA Middle inertia	2000r/min	MFMA042P1*	400W	MCDDT3520	C-frame
			MFMA152P1*	1.5kW	MDDDT5540	D-frame
			MFMA252P1*	2.5kW	MEDDT7364	E-frame
			MFMA452P1*	4.5kW	MFDDTB3A2	F-frame
3-phase, 200V	MGMA Middle inertia	1000r/min	MGMA092P1*	900W	MDDDT5540	D-frame
			MGMA202P1*	2.0kW	MFDDTA390	F-frame
			MGMA302P1*	3.0kW	MFDDTA390	F-frame
			MGMA452P1*	4.5kW	MFDDTB3A2	F-frame

<Note>

Suffix of " * " in the applicable motor model represents the motor structure.

Absolute/Incremental Specifications, 17-bit

<Remarks> Do not use in other combinations than those listed below.

Power supply	Applicable motor			Applicable driver		
	Motor series	Rated rotational speed	Model	Rated output	Model	Frame
Single phase, 200V	MAMA Ultra low inertia	5000r/min	MAMA012S1*	100W	MADDT1207	A-frame
			MAMA022S1*	200W	MBDDT2210	B-frame
			MAMA042S1*	400W	MCDDT3520	C-frame
			MAMA082S1*	750W	MDDDT5540	D-frame
3-phase, 200V	MQMA Low inertia	3000r/min	MQMA011S1*	100W	MADDT1107	A-frame
			MQMA021S1*	200W	MBDDT2110	B-frame
			MQMA041S1*	400W	MCDDT3120	C-frame
			MQMA012S1*	100W	MADDT1205	A-frame
Single phase, 100V	MSMD Low inertia	3000r/min	MQMA022S1*	200W	MADDT1207	A-frame
			MQMA042S1*	400W	MBDDT2210	B-frame
			MSMD5AZS1*	50W	MADDT1107	A-frame
			MSMD011S1*	100W	MADDT1107	A-frame
Single phase, 200V	MSMA Low inertia	3000r/min	MSMD021S1*	200W	MBDDT2110	B-frame
			MSMD041S1*	400W	MCDDT3120	C-frame
			MSMD5AZS1*	50W	MADDT1205	A-frame
			MSMD012S1*	100W	MADDT1207	A-frame
Single/3-phase, 200V	MSMA Low inertia	3000r/min	MSMD022S1*	200W	MADDT1207	A-frame
			MSMD042S1*	400W	MBDDT2210	B-frame
			MSMD082S1*	750W	MCDDT3520	C-frame
			MSMA102S1*	1.0kW	MDDDT5540	D-frame
3-phase, 200V	MSMA Low inertia	3000r/min	MSMA152S1*	1.5kW	MDDDT5540	D-frame
			MSMA202S1*	2.0kW	MEDDT7364	E-frame
			MSMA302S1*	3.0kW	MFDDTA390	F-frame
			MSMA402S1*	4.0kW	MFDDTA390	F-frame
3-phase, 200V	MSMA Low inertia	3000r/min	MSMA502S1*	5.0kW	MFDDTB3A2	F-frame
			MSMA502S1*	5.0kW	MFDDTB3A2	F-frame

(continues to next page)

10. Check of the Combination of the Driver and the Motor

Power supply	Applicable motor			Applicable driver		
	Motor series	Rated rotational speed	Model	Rated output	Model	Frame
Single/3-phase, 200V	MDMA Middle inertia	2000r/min	MDMA102S1*	1.0kW	MDDDT3530	D-frame
3-phase, 200V			MDMA152S1*	1.5kW	MDDDT5540	
			MDMA202S1*	2.0kW	MEDDT7364	E-frame
			MDMA302S1*	3.0kW	MFDDTA390	
			MDMA402S1*	4.0kW	MFDDTB3A2	F-frame
MDMA502S1*			5.0kW			
Single/3-phase, 200V	MHMA High inertia	2000r/min	MHMA052S1*	500W	MCDDT3520	C-frame
3-phase, 200V			MHMA102S1*	1.0kW	MDDDT3530	D-frame
			MHMA152S1*	1.5kW	MDDDT5540	
			MHMA202S1*	2.0kW	MEDDT7364	E-frame
			MHMA302S1*	3.0kW	MFDDTA390	
MHMA402S1*			4.0kW	MFDDTB3A2	F-frame	
MHMA502S1*	5.0kW					
Single/3-phase, 200V	MFMA Middle inertia	2000r/min	MFMA042S1*	400W	MCDDT3520	C-frame
3-phase, 200V			MFMA152S1*	1.5kW	MDDDT5540	D-frame
			MFMA252S1*	2.5kW	MEDDT7364	E-frame
			MFMA452S1*	4.5kW	MFDDTB3A2	F-frame
Single/3-phase, 200V	MGMA Middle inertia	1000r/min	MGMA092S1*	900W	MDDDT5540	D-frame
3-phase, 200V			MGMA202S1*	2.0kW	MFDDTA390	F-frame
			MGMA302S1*	3.0kW		
			MGMA452S1*	4.5kW		

<Notes>

- 1) Suffix of " * " in the applicable motor model represents the motor structure.
- 2) Default of the driver is set for the incremental encoder specifications.
When you use in absolute, make the following operations.
 - a) Install a battery for absolute encoder.
 - b) Switch the parameter Pr0B (Absolute encoder setup) from "1 (default)" to "0".
- 3) No wiring for back up battery is required when you use the absolute 17-bit encoder in incremental.

After-Sale Service (Repair)

Repair

Consult to a dealer from whom you have purchased the product for details of repair. When the product is incorporated to the machine or equipment you have purchased, consult to the manufacture or the dealer of the machine or equipment.

Cautions for Proper Use

- This product is intended to be used with a general industrial product, but not designed or manufactured to be used in a machine or system that may cause personal death when it is failed.
- Install a safety equipments or apparatus in your application, when a serious accident or loss of property is expected due to the failure of this product.
- Consult us if the application of this product is under such special conditions and environments as nuclear energy control, aerospace, transportation, medical equipment, various safety equipments or equipments which require a lesser air contamination.
- We have been making the best effort to ensure the highest quality of the products, however, application of exceptionally larger external noise disturbance and static electricity, or failure in input power, wiring and components may result in unexpected action. It is highly recommended that you make a fail-safe design and secure the safety in the operative range.
- If the motor shaft is not electrically grounded, it may cause an electrolytic corrosion to the bearing, depending on the condition of the machine and its mounting environment, and may result in the bearing noise. Checking and verification by customer is required.
- Failure of this product depending on its content, may generate smoke of about one cigarette. Take this into consideration when the application of the machine is clean room related.
- Please be careful when using in an environment with high concentrations of sulphur or sulphuric gases, as sulphuration can lead to disconnection from the chip resistor or a poor contact connection.
- Take care to avoid inputting a supply voltage which significantly exceeds the rated range to the power supply of this product. Failure to heed this caution may result in damage to the internal parts, causing smoking and/or a fire and other trouble.

Technical information

Technical information of this product (Instruction Manual, CAD data) can be downloaded from the following web site.

http://industrial.panasonic.com/ww/i_e/25000/motor_fa_e/motor_fa_e.html

MEMO (Fill in the blanks for reference in case of inquiry or repair.)

Date of purchase		Model No.	M <input type="checkbox"/> DD _____
			M <input type="checkbox"/> MD _____
			M <input type="checkbox"/> MA _____
Dealer			
	Tel : () -		

Motor Company

Matsushita Electric Industrial Co., Ltd.

7-1-1 Morofuku, Daito, Osaka, 574-0044, Japan Tel : (81)-72-871-1212

单击下面可查看定价，库存，交付和生命周期等信息

[>>Panasonic\(松下\)](#)