

Notification about the transfer of the semiconductor business

The semiconductor business of Panasonic Corporation was transferred on September 1, 2020 to Nuvoton Technology Corporation (hereinafter referred to as "Nuvoton"). Accordingly, Panasonic Semiconductor Solutions Co., Ltd. became under the umbrella of the Nuvoton Group, with the new name of Nuvoton Technology Corporation Japan (hereinafter referred to as "NTCJ").

In accordance with this transfer, semiconductor products will be handled as NTCJ-made products after September 1, 2020. However, such products will be continuously sold through Panasonic Corporation.

Publisher of this Document is NTCJ.

If you would find description "Panasonic" or "Panasonic semiconductor solutions", please replace it with NTCJ.

※ Except below description page

"Request for your special attention and precautions in using the technical information and semiconductors described in this book"

Nuvoton Technology Corporation Japan

種別/Type	シリコン MOS形集積回路/Silicon MOSFET type Integrated Circuit		
用途/Application	スイッチング電源制御用/For Switching Power Supply Control		
構造/Structure	CMOS形/CMOS type		
等価回路/Equivalent Circuit	添付図/See Figure. 7		
外形/Out Line	DIP7-A1-B	マーク記号/マーキング/Marking	MIP2K5

A. 絶対最大定格/ABSOLUTE MAXIMUM RATINGS (Ta=25°C±3°C)

NO.	項目/Item	記号/Symbol	定格/Ratings	単位/Unit	備考/Note
1	ドレイン電圧 DRAIN Voltage	VD	-0.3 ~ 700	V	※1: 下記パルス幅以内での保証とする (It is guaranteed within the pulse as below.) オン時ブランキング幅 + 過電流保護遅れ時間 Leading Edge Blanking Pulse + Current Limit Delay ton(BLK) + td(OCL)
2	VCC電圧 VCC Voltage	VCC	-0.3 ~ 45	V	
3	VDD電圧 VDD Voltage	VDD	-0.3 ~ 8	V	
4	フィードバック電圧 FEEDBACK Voltage	VFB	-0.3 ~ 8	V	
5	フィードバック電流 FEEDBACK Current	IFB	500	μA	
6	CL端子電圧 CL Voltage	VCL	-0.3 ~ 8	V	
7	CL端子電流 CL Current	ICL	150	μA	
8	出力ピーク電流 Output Peak Current	IDP	3.5 (※1)	A	
9	チャンネル部温度 Channel Temperature	Tch	150	°C	
10	保存温度 Storage Temperature	Tstg	-55 ~ +150	°C	

B. 電気的特性/ELECTRICAL CHARACTERISTICS

測定条件/Measure condition (TC=25°C±2°C)

No.	項目/Item	記号/Symbol	測定条件/Measure Condition (測定図-1 参照/See Figure 1)	Typ.	Limit		Unit
					Min	Max	

【コントロール機能/CONTROL FUNCTIONS】 *は設計保証項目/Design Guarantee Item

1	出力周波数 Output Frequency	fosc	VCC=15 V, VD=5 V, IFB=20 μA, ICL=50 μA	100	90	110	kHz
		fosc(L)	VCC=15 V, VD=5 V, IFB:OPEN, ICL<ICL1	12	9	15	
2	周波数ジッター偏差 Jitter Frequency Deviation	Δf	VCC=15 V, VD=5 V, IFB=20 μA, ICL=50 μA	5.5	-	-	kHz
*3	周波数ジッター変調率 Jitter Frequency Modulation Rate	fM	VCC=15 V, VD=5 V, IFB=20 μA, ICL=50 μA	260	-	-	Hz
4	最大デューティサイクル Maximum Duty Cycle	MAXDC	VCC=15 V, VD=5 V, IFB=20 μA, ICL=50 μA	47.5	45	50	%

製品規格 / Product Specification							
品種名 / Type Number : MIP2K50MTSCF							
No.	項目 / Item	記号 / Symbol	測定条件 / Measure Condition (測定図-1 参照 / See Figure 1)	Typ.	Limit		Unit
					Min	Max	
【コントロール機能 / CONTROL FUNCTIONS】							
5	VDD基準電圧 VDD Voltage	VDD	VCC=15 V, VD=5 V, IFB=20 μ A, ICL=50 μ A	5.9	5.4	6.4	V
6	VDD停止電圧 UV Lockout Threshold Voltage	VUV	VD=5 V, IFB=20 μ A, ICL=50 μ A	5.1	4.6	5.6	V
7	VCC起動電圧 VCC Start Voltage	VCC(ON)	VD=5 V, IFB=20 μ A, ICL=50 μ A	6.9	5.9	7.9	V
8	VCC充電停止電圧 VCC Charge Stop Threshold Voltage	VCC1	VD=40 V, FB:OPEN, CL:OPEN	12.8	11.8	13.8	V
9	フィードバック電流 Feedback Threshold Current	IFB1	ON→OFF VCC=15 V, VD=5 V, ICL=50 μ A	160	80	240	μ A
10	フィードバック電流ヒステリシス Feedback Hysteresis Current	IFBHYS	VCC=15 V, VD=5 V, ICL=50 μ A	8	-	-	μ A
11	重負荷時FB端子電流 FB Pin Current at Heavy Load	IFB0	ICC0 → ICC VCC=15 V, VD=5 V, ICL=50 μ A	15	10	20	μ A
12	FB端子電圧 FB Pin Voltage	VFB	VCC=15 V, VD=5 V, IFB=20 μ A, ICL=50 μ A	1.0	0.7	1.3	V
13	回路消費電流 Supply Current	ICC	VCC=15 V, VD=5 V, IFB=20 μ A, ICL=50 μ A	0.48	0.30	0.60	mA
14	軽負荷時回路消費電流 Supply Current at Light Load	ICC(OFF)	VCC=15 V, VD=5 V IFB=IFB1+5 μ A, ICL=50 μ A	0.35	0.26	0.44	mA
15	重負荷時回路消費電流 Supply Current at Heavy Load	ICC0	VCC=15 V, VD=5 V, IFB=OPEN, ICL=50 μ A	0.67	0.50	0.84	mA
16	VDD充電電流 VDD Charging Current	Ich1	VDD=0 V, VD=40 V, FB:OPEN, CL:OPEN	-6.3	-9.0	-3.5	mA
		Ich2	VDD=4 V, VD=40 V, FB:OPEN, CL:OPEN	-2.1	-3.5	-0.7	mA
17	CL端子電圧 CL Pin Voltage	VCL	VCC=15 V, VD=5 V, FB:OPEN, ICL=ICL1	2.3	2.0	2.6	V
18	fosc 低下時CL端子電流 Dropped fosc CL Pin Current	ICL1	fosc → fosc(L) ※Figure 3 VCC=15 V, VD=5 V, FB:OPEN	22	16.5	27.5	μ A
19	fosc 低下時CL端子電流ヒステリシス CL Pin Hysteresis Current	ICLHYS	※Figure 3 VCC=15 V, VD=5 V, FB:OPEN	1.5	-	-	μ A
【保護機能 / CIRCUIT PROTECTIONS:】							
20	過電流保護検出 Self Protection Current Limit	ILIMIT	※Figure 2/Figure 4 VCC=15 V, FB:OPEN, ICL=50 μ A, DUTY=30%	1.0	0.9	1.1	A
21	ILIMIT 補正係数 ILIMIT modified coefficient	R_slope	※Figure 2/Figure 4 VCC=15 V, FB:OPEN, ICL=50 μ A	30	-	-	mA/ μ s
22	最小ILIMIT Minimum ILIMIT	ILIMITmin	Ton=3 μ sec VCC=15 V, FB:OPEN, ICL=0 μ A	300	170	430	mA
*23	軽負荷時ドレイン電流 Drain Current at Light Load	ID(OFF)	Ton=3 μ sec VCC=15 V, IFB=IFB1-IFBHYS, ICL=50 μ A	150	50	250	mA
*24	オン時ブランピング幅 Leading Edge Blanking Delay	ton(BLK)	VCC=15 V, FB:OPEN, ICL=50 μ A	290	230	350	ns

No.	項目/Item	記号/ Symbol	測定条件/Measure Condition (測定図-1 参照/See Figure 1)	Typ.	Limit		Unit
					Min	Max	
【出力/OUTPUT】							
*25	過電流保護遅れ時間 Current Limit Delay	td(OCL)		150	100	200	ns
26	過電圧保護検出 Over Voltage Protection	VCC(OV)	VDD=5 V, FB:OPEN, ICL=50 μ A	24.5	22	27	V
*27	過熱保護温度 Thermal Shutdown Temperature	TOTP		140	130	150	$^{\circ}$ C
28	ラッチリセット電圧 Power-up Reset Threshold Voltage	VDDreset		2.6	1.8	3.5	V
29	オン抵抗 ON-State Resistance	RDS(ON)	ID=100 mA	4.8	-	6.0	Ω
30	オフ時ドレイン端子リーク電流 OFF-State Current	IDSS	VCC=26 V, VD=650 V, FB:OPEN, CL:OPEN	10	-	20	μ A
31	ドレイン耐圧 Breakdown Voltage	VDSS	VCC=26 V, ID=100 μ A, FB:OPEN, CL:OPEN	-	700	-	V
32	立ち上がり時間 Rise Time	tr	※Figure 5 VCC=15 V, VD=5 V, FB:OPEN, ICL=50 μ A	100	-	-	ns
33	立ち下がり時間 Fall Time	tf	※Figure 5 VCC=15 V, VD=5 V, FB:OPEN, ICL=50 μ A	50	-	-	ns
【電源電圧/SUPPLY】							
34	最小ドレイン電圧 Drain Supply Voltage	VD(MIN)	VCC:OPEN, FB:OPEN, CL:OPEN	-	50	-	V

【Fig. 1 : 測定回路図/Measure Circuit】

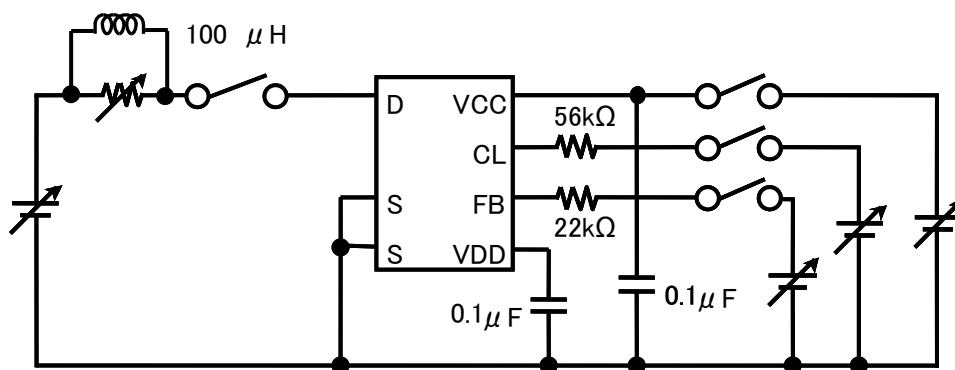

【Fig. 2: ILIMIT vs. ICL Typical Characteristic】

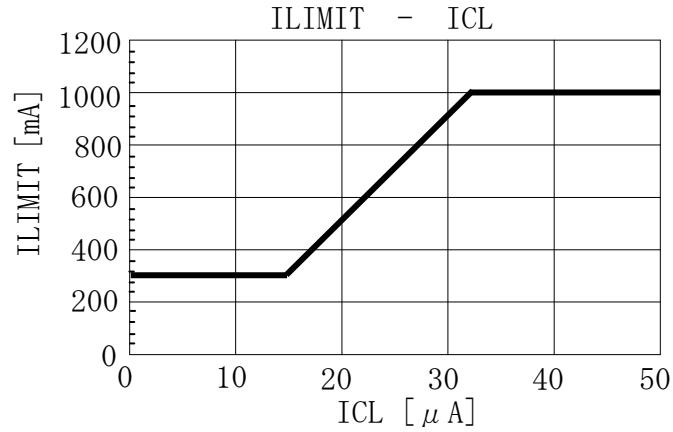

【Fig. 3: fosc vs. ICL Typical Characteristic】

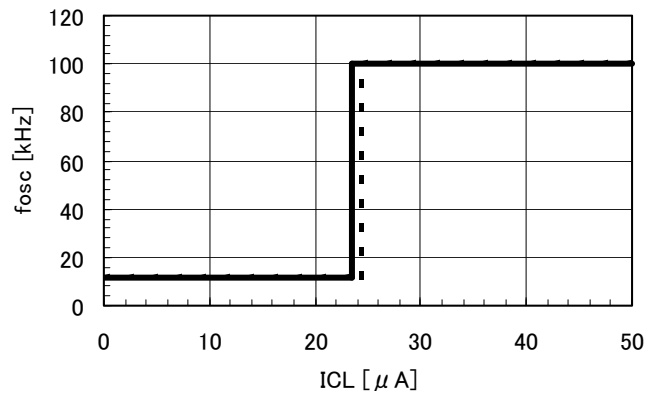

【Fig. 4: ILIMIT Measurement】

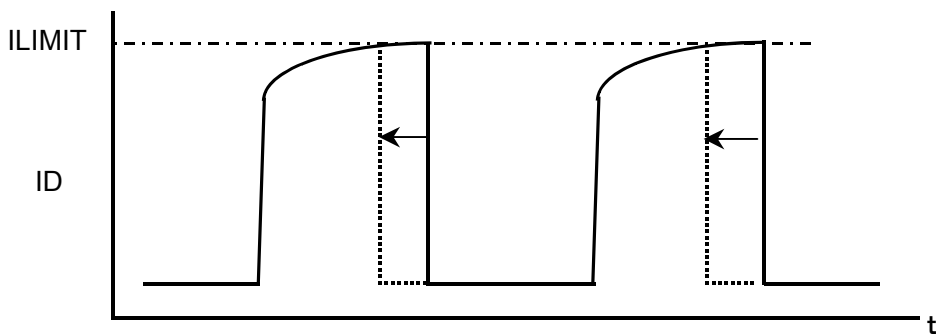

$$R_{\text{slope}} ; \{(\text{ILIMIT at Duty=30\%}) - (\text{ILIMIT at Duty=10\%})\} / \{(\text{Ton at Duty=30\%}) - (\text{Ton at Duty=10\%})\}$$

【Fig. 5 : tr, tf Measurement】

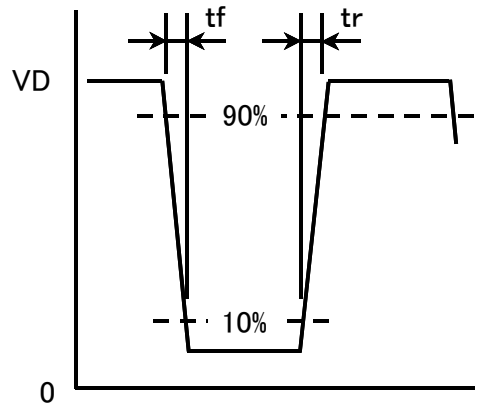

【Fig. 6: Δf , fm measurement】

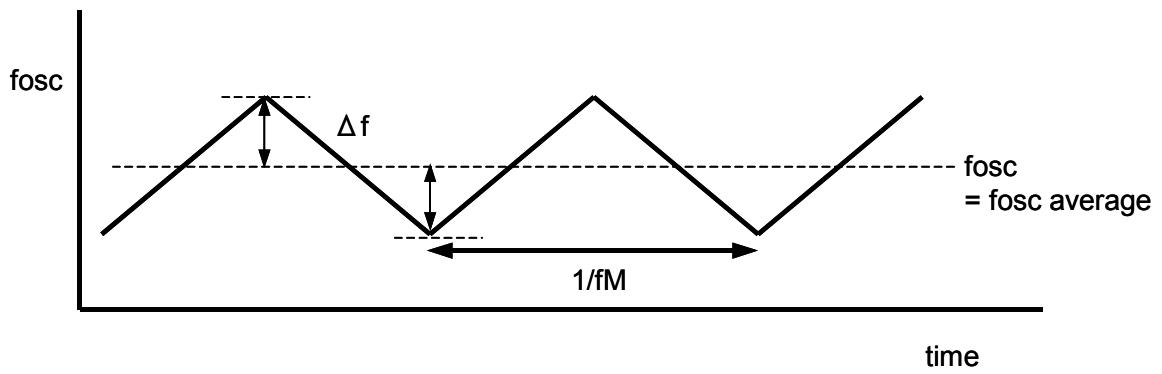

【Fig. 7: Block Diagram】

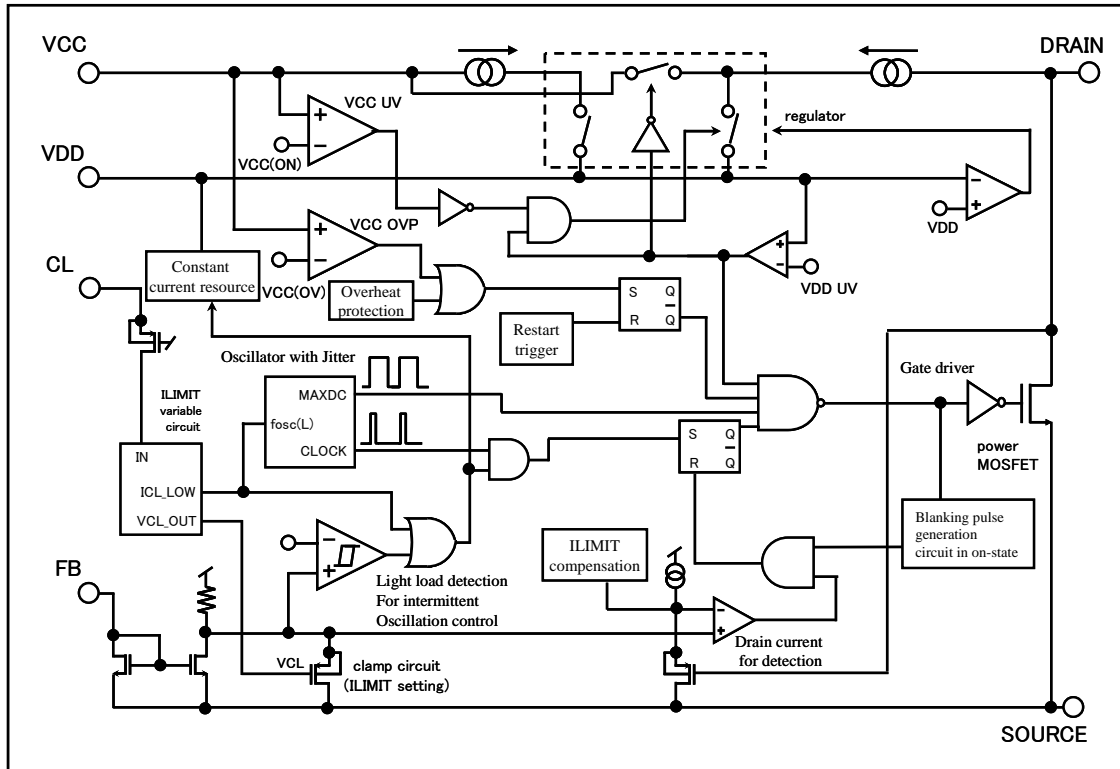

【Fig. 8: 端子配置図/Pin Layout】

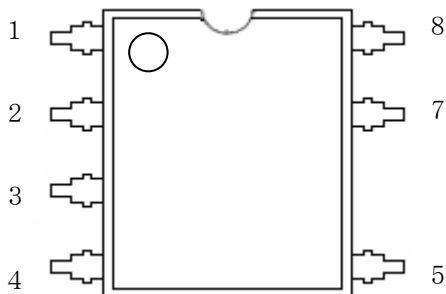

Pin No.	端子名/Terminal Name
1	VDD
2	FB
3	CL
4	VCC
5	Drain
6	—
7	Source
8	Source

【使用上の注意1／Precautions for Use 1】

VDD 端子-GND間には、0.1 μ F以上のセラミックコンデンサを使用してください。
Connect a ceramic capacitor with value $>0.1 \mu$ F between VDD pin and GND.

【使用上の注意2／Precautions for Use 2】

以下のような条件では、破損し場合によっては破裂、発煙の可能性があります。以下の使用は避けていただくとともに、安全規格上の認定試験において、対策が必要になる場合には、入力段へのヒューズ追加や制御端子-GND間へのツェナーダイオード追加などの対策を講じてください。具体的な対策については個別に相談させていただくことも可能ですが、最終的にはお客様側にてご判断をお願いいたします。

The IPD has risks for break-down or burst or giving off smoke in following conditions. Avoid the following use. Fuse should be added at the input side or connect zener diode between control pins and GND, etc as a countermeasure to pass regulatory Safety Standard. Concrete countermeasure could be provided individually. However, customer should make the final judgment.

- (1) DRAIN 端子と VDD 端子を逆にして、電源基板へ挿入する。
Reverse the DRAIN pin and VDD pin connection to the power supply board.
- (2) DRAIN 端子と VDD 端子をショートする。
DRAIN pin short to VDD pin.
- (3) DRAIN 端子と FB 端子をショートする。
DRAIN pin short to FB pin.
- (4) DRAIN 端子と CL 端子をショートする。
DRAIN pin short to CL pin.
- (5) DRAIN 端子と VCC 端子をショートする。
DRAIN pin short to VCC pin.
- (6) VCC 端子と VDD 端子をショートする。
VCC pin short to VDD pin.
- (7) VCC 端子と FB 端子をショートする。
VCC pin short to FB pin.
- (8) VCC 端子と CL 端子をショートする。
VCC pin short to CL pin.

Request for your special attention and precautions in using the technical information and semiconductors described in this book

- (1) If any of the products or technical information described in this book is to be exported or provided to non-residents, the laws and regulations of the exporting country, especially, those with regard to security export control, must be observed.
- (2) The technical information described in this book is intended only to show the main characteristics and application circuit examples of the products. No license is granted in and to any intellectual property right or other right owned by Panasonic Corporation, Nuvoton Technology Corporation Japan or any other company. Therefore, no responsibility is assumed by our company as to the infringement upon any such right owned by any other company which may arise as a result of the use of technical information de-scribed in this book.
- (3) The products described in this book are intended to be used for general applications (such as office equipment, communications equipment, measuring instruments and household appliances), or for specific applications as expressly stated in this book.
Please consult with our sales staff in advance for information on the following applications, moreover please exchange documents separately on terms of use etc.: Special applications (such as for in-vehicle equipment, airplanes, aerospace, automotive equipment, traffic signaling equipment, combustion equipment, medical equipment and safety devices) in which exceptional quality and reliability are required, or if the failure or malfunction of the products may directly jeopardize life or harm the human body.
Unless exchanging documents on terms of use etc. in advance, it is to be understood that our company shall not be held responsible for any damage incurred as a result of or in connection with your using the products described in this book for any special application.
- (4) The products and product specifications described in this book are subject to change without notice for modification and/or improvement. At the final stage of your design, purchasing, or use of the products, therefore, ask for the most up-to-date Product Standards in advance to make sure that the latest specifications satisfy your requirements.
- (5) When designing your equipment, comply with the range of absolute maximum rating and the guaranteed operating conditions (operating power supply voltage and operating environment etc.). Especially, please be careful not to exceed the range of absolute maximum rating on the transient state, such as power-on, power-off and mode-switching. Otherwise, we will not be liable for any defect which may arise later in your equipment.
Even when the products are used within the guaranteed values, take into the consideration of incidence of break down and failure mode, possible to occur to semiconductor products. Measures on the systems such as redundant design, arresting the spread of fire or preventing glitch are recommended in order to prevent physical injury, fire, social damages, for example, by using the products.
- (6) Comply with the instructions for use in order to prevent breakdown and characteristics change due to external factors (ESD, EOS, thermal stress and mechanical stress) at the time of handling, mounting or at customer's process. We do not guarantee quality for disassembled products or the product re-mounted after removing from the mounting board.
When using products for which damp-proof packing is required, satisfy the conditions, such as shelf life and the elapsed time since first opening the packages.
- (7) When reselling products described in this book to other companies without our permission and receiving any claim of request from the resale destination, please understand that customers will bear the burden.
- (8) This book may be not reprinted or reproduced whether wholly or partially, without the prior written permission of our company.

No.070920

单击下面可查看定价，库存，交付和生命周期等信息

[>>Panasonic\(松下\)](#)