

Notification about the transfer of the semiconductor business

The semiconductor business of Panasonic Corporation was transferred on September 1, 2020 to Nuvoton Technology Corporation (hereinafter referred to as "Nuvoton"). Accordingly, Panasonic Semiconductor Solutions Co., Ltd. became under the umbrella of the Nuvoton Group, with the new name of Nuvoton Technology Corporation Japan (hereinafter referred to as "NTCJ").

In accordance with this transfer, semiconductor products will be handled as NTCJ-made products after September 1, 2020. However, such products will be continuously sold through Panasonic Corporation.

Publisher of this Document is NTCJ.

If you would find description "Panasonic" or "Panasonic semiconductor solutions", please replace it with NTCJ.

※ Except below description page

"Request for your special attention and precautions in using the technical information and semiconductors described in this book"

Nuvoton Technology Corporation Japan

Type	Silicon MOSFET type Integrated Circuit		
Application	For Switching Power Supply Control		
Structure	Bi-CMOS type		
Equivalent Circuit	Figure 8		
Out Line	TO-220C-G3-B	Marking	MIP2N1BUK

A . ABSOLUTE MAXIMUM RATINGS (Ta=25 ± 3)

NO.	Item	Symbol	Rating	Unit	Note
1	DRAIN Voltage	VD	- 0.3 ~ 700	V	1 : It is guaranteed within the Minimum On Pulse Width (MIN(PW)).
2	CONTROL Voltage	VC	- 0.3 ~ 8.0	V	
3	Output Peak Current 1	IDP	1.3	A	
4	Junction Temperature	Tj	+150		
5	Storage Temperature	Tstg	- 55 ~ + 150		

B . OPERATING GUARANTEE CONDITIONS

NO.	Item	Symbol	Rating	Unit	Note
1	Operation guarantee temperature 2	Top	- 40 ~ +125		2 : Operation ambient temperature(Ta)

Attention :

The absolute maximum ratings are standards that must not be exceeded, even for an instant.
 If any of these rating would be exceeded, it may cause deterioration or damage or destruction of the IC.
 Moreover, these operations with exceeded ratings may cause failure to any other components.
 Please design so as not to exceed the absolute maximum rating in any operating conditions.
 Before using or designing, refer to and comply with the precautions and conditions set forth in these

C . THERMAL RESISTANCE

NO.	Item	Symbol	Typ value	Unit	Note
1	Junction to Ambient	Rthj-a	69.0	/W	10mm X 10mm Epoxy Board
2	Junction to Ambient	Rthj-a	42.7	/W	30mm X 20mm Epoxy Board
3	Junction to Case	Rthj-c	3.0	/W	

D . ELECTRICAL CHARACTERISTICS
[CONTROL FUNCTIONS]

Measurement condition (Ta=25 ±3)

* Design Guarantee Item, ** Reference Item

No.	Item	Symbol	Measurement Condition(Figure 1)	Typ	Min	Max	Unit
1	Output Frequency	fosc	VC=VC(CNT)-0.4 V, VD=5 V	44.0	39.6	48.4	kHz
** 2	Jitter Frequency Deviation	d_fosc	See Figure 3 VC=VC(CNT)-0.4 V, VD=5 V	2.3			kHz
** 3	Jitter Frequency Modulation Rate	fM	See Figure 3 VC=VC(CNT)-0.4 V, VD=5 V	270			Hz
4	Maximum Duty Cycle	MAXDC	VC=VC(CNT)-0.4 V, VD=5 V	54	50	58	%
5	Before Auto-restart Current	IC(SB)1	VC=VC(ON)-0.06V, VD=5 V	0.40	0.16	0.50	mA
6	After Off-state Current	IC(SB)2	VC=VC(CNT), VD=5 V	0.40	0.16	0.50	mA
7	Operating Current	IC(OP)	VC=VC(CNT)-0.2 V, VD=5 V	0.50	0.17	0.83	mA
8	Auto-restart Control Pin Voltage	VC(ON)	VD=5 V	6.10	5.60	6.60	V
9	Shutdown Control Pin Voltage	VC(OFF)	VD=5 V	4.75	4.30	5.20	V
10	Auto-restart hysteresis Voltage	d_VC	VC(ON) VC(OFF)	1.35	0.95	1.75	V
11	Control Pin Clamp Voltage	VC(CLP)	IC=3 mA	6.60	6.00	7.20	V
** 12	Auto-restart duty cycle	TSW/TTIM	See Figure 4 S1=OPEN	8			%
** 13	Auto-restart frequency	fTIM	See Figure 4 S1=OPEN	30			Hz
14	Control Pin Charging Current	IC(CHG)1	VC=0 V, VD=50 V	-4.10	-5.25	-2.56	mA
		IC(CHG)2	VC=5 V, VD=50 V	-2.20	-3.10	-1.24	mA
15	Control Pin Voltage	VC(CNT)	VD=5 V	5.90	5.40	6.40	V
** 16	Control Pin Voltage hysteresis	d_VC(CNT)	VD=5 V	10			mV
* 17	Soft Start time	Tsoft	VC=VC(CNT)-0.1 V	4.5	2.5	6.5	ms
18	Control Pin Voltage-Shutdown Control Pin Voltage hysteresis	d_VC2	VC(CNT) - d_VC(CNT) VC(OFF)	1.15	0.70	1.60	V

*Design Guarantee Item : These are the guaranteed value of as a design, and not inspected at shipment.

**Reference Item : These are design reference values, and not guaranteed by shipping inspection.

[PROTECTIVE FUNCTIONS] * Design Guarantee Item, ** Reference Item

No.	Item	Symbol	Measurement Condition(Figure 1)	Typ	Min	Max	Unit
** 19	Variable rate of VEAO reference value	Reao	See Figure 5 DUTY=MAXDC Reao=(VEAO_1-VEAO_2) V/0.1 V	-4.0			V/V
* 20	VEAO reference value	VEAO_MAX	See Figure 5 DUTY=MAXDC	1.68	1.44	1.92	V
* 21	VC Voltage at VEAO_MAX	VC_MAX	See Figure 5 DUTY=MAXDC	5.80	5.40	6.20	V
22	Self Protection Current Limit	ILIMIT	See Figure 2 and 6 Ton=6.8 μs VC=VC(CNT)-0.4 V	0.400	0.360	0.440	A
* 23	Leading Edge Blanking Delay	ton(BLK)		370	295	445	ns
** 24	Current Limit Delay	td(OCL)		150			ns
25	Minimum On Pulse Width	MIN(PW)	VD=50 V VC=VC(CNT) - d_VC(CNT)	550		690	ns
* 26	Thermal Shutdown Temperature 3	TOTP		150	140	160	
** 27	Thermal Shutdown Temperature Hysteresis	d_TOTP		70			
28	Power-up Reset Threshold Voltage	VCreset		2.60	1.80	3.50	V

*3:The Absolute maximum Temperature of this product is 150deg.
 This over temperature detection function does not intend to limit the CHIP temperature.
 Thus, the above Absolute Maximum Temperature never is over to use.
 If any of these rating would be exceeded during operation, the device electrical characteristics may be irreparably altered and the reliability and lifetime of the device can no longer be guaranteed.
 Moreover, these operations with exceeded ratings may cause break down, damage and/or degradation to any other equipment.
 Applications using the device should be designed such that each maximum rating will never be exceeded in any operating conditions.

About this over temperature detection function,
 the inspection at actual temperature is not performed at shipping inspection. Only the check of detector circuit operation is performed by the TEST function.

*Design Guarantee Item : These are the guaranteed value of as a design, and not inspected at shipment.

**Reference Item : These are design reference values, and not guaranteed by shipping ins

[Output] * Design Guarantee Item, ** Reference Item

No.	Item	Symbol	Measurement Condition(Figure 1)	Typ	Min	Max	Unit
29	ON-State Resistance	RDS(ON)	ID=0.1 A	16.9		21.0	
30	OFF-State Current	IDSS	VD=650 V, VC > VC(CNT)	10		20	μ A
31	Breakdown Voltage	VDSS	ID=100 μ A, VC > VC(CNT)		700		V
** 32	Rise Time	tr	See Figure 7	50			ns
** 33	Fall Time	tf	See Figure 7	30			ns

[Supply]

No.	Item	Symbol	Measurement Condition(Figure 1)	Typ	Min	Max	Unit
34	Drain Supply Voltage	VD(MIN)	S1=OPEN Ta=-40 ~ 125 4		50		V

4: This item shows the DRAIN voltage required in order that IPD can start an oscillation within operation guarantee temperature. And the inspection at Ta= 25 deg and 125 deg is performed at shipping inspection.

*Design Guarantee Item : These are the guaranteed value of as a design, and not inspected at shipment.

**Reference Item : These are design reference values, and not guaranteed by shipping inspection.



D. ELECTRICAL CHARACTERISTICS
 [CONTROL FUNCTIONS]

Measure condition (Ta=125 ±5)

* Design Guarantee Item, ** Reference Item

No.	Item	Symbol	Measurement Condition(Figure 1)	Typ	Min	Max	Unit
35	Output Frequency	fosc	VC=VC(CNT)-0.4 V, VD=5 V	46.0	41.4	50.6	kHz
** 36	Jitter Frequency Deviation	d_fosc	See Figure 3 VC=VC(CNT)-0.4 V, VD=5 V	2.1			kHz
** 37	Jitter Frequency Modulation Rate	fM	See Figure 3 VC=VC(CNT)-0.4 V, VD=5 V	200			Hz
38	Maximum Duty Cycle	MAXDC	VC=VC(CNT)-0.4 V, VD=5 V	54	50	58	%
39	Before Auto-restart Current	IC(SB)1	VC=VC(ON)-0.06V,VD=5 V	0.39	0.15	0.50	mA
40	After Off-state Current	IC(SB)2	VC=VC(CNT),VD=5 V	0.39	0.15	0.50	mA
41	Operating Current	IC(OP)	VC=VC(CNT)-0.2 V, VD=5 V	0.48	0.15	0.81	mA
42	Auto-restart Control Pin Voltage	VC(ON)	VD=5 V	6.15	5.65	6.65	V
43	Shutdown Control Pin Voltage	VC(OFF)	VD=5 V	4.80	4.34	5.25	V
44	Auto-restart hysteresis Voltage	d_VC	VC(ON) VC(OFF)	1.35	0.95	1.75	V
45	Control Pin Clamp Voltage	VC(CLP)	IC=3 mA	6.60	6.00	7.20	V
** 46	Auto-restart duty cycle	TSW/TTIM	See Figure 4 S1=OPEN	7			%
** 47	Auto-restart frequency	fTIM	See Figure 4 S1=OPEN	26			Hz
48	Control Pin Charging Current	IC(CHG)1	VC=0 V, VD=50 V	-2.50	-3.20	-1.59	mA
		IC(CHG)2	VC=5 V, VD=50 V	-1.30	-1.80	-0.71	mA
49	Control Pin Voltage	VC(CNT)	VD=5 V	5.90	5.40	6.40	V
** 50	Control Pin Voltage hysteresis	d_VC(CNT)	VD=5 V	10			mV
* 51	Soft Start time	Tsoft	VC=VC(CNT)-0.1 V	5.5	3.1	7.9	ms
52	Control Pin Voltage-Shutdown Control Pin Voltage hysteresis	d_VC2	VC(CNT) - d_VC(CNT) VC(OFF)	1.10	0.65	1.55	V

*Design Guarantee Item : These are the guaranteed value of as a design, and not inspected at shipment.

**Reference Item : These are design reference values, and not guaranteed by shipping ins

[PROTECTIVE FUNCTIONS] * Design Guarantee Item, ** Reference Item

No.	Item	Symbol	Measurement Condition(Figure 1)	Typ	Min	Max	Unit
** 53	Variable rate of VEAO reference value	Reao	See Figure 5 DUTY=MAXDC Reao=(VEAO_1-VEAO_2) V/0.1 V	-3.8			V/V
* 54	VEAO reference value	VEAO_MAX	See Figure 5 DUTY=MAXDC	2.12	1.75	2.49	V
* 55	VC Voltage at VEAO_MAX	VC_MAX	See Figure 5 DUTY=MAXDC	5.60	5.20	6.00	V
56	Self Protection Current Limit	ILIMIT	See Figure 2 and 6 Ton=6.8 μs VC=VC(CNT)-0.4 V	0.380	0.312	0.440	A
* 57	Leading Edge Blanking Delay	ton(BLK)		350	280	420	ns
** 58	Current Limit Delay	td(OCL)		170			ns
59	Minimum On Pulse Width	MIN(PW)	VD=50 V VC=VC(CNT) - d_VC(CNT)	530		670	ns
60	Power-up Reset Threshold Voltage	VCreset		1.90	1.20	2.90	V

*Design Guarantee Item : These are the guaranteed value of as a design, and not inspected at shipment.

**Reference Item : These are design reference values, and not guaranteed by shipping inspection.

[Output]

* Design Guarantee Item, ** Reference Item

No.	Item	Symbol	Measurement Condition(Figure 1)	Typ	Min	Max	Unit
61	ON-State Resistance	RDS(ON)	ID=0.1 A	27.0		34.0	
62	OFF-State Current	IDSS	VD=650 V, VC > VC(CNT)	15		30	μ A
63	Breakdown Voltage	VDSS	ID=100 μ A, VC > VC(CNT)		700		V
** 64	Rise Time	tr	See Figure 7	80			ns
** 65	Fall Time	tf	See Figure 7	35			ns

*Design Guarantee Item : These are the guaranteed value of as a design, and not inspected at shipment.

**Reference Item : These are design reference values, and not guaranteed by shipping inspection.

[Figure 1: Measurement Circuit] *This measurement circuit can not be used for ILIMIT measurement.

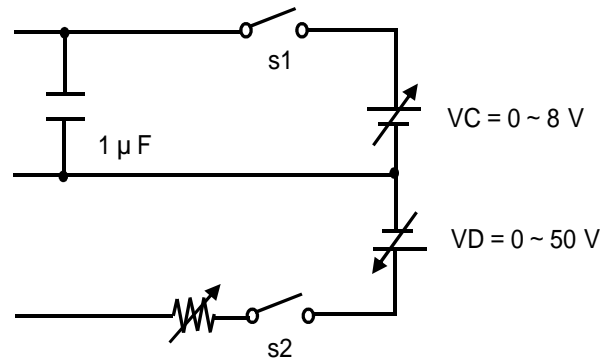

Terminal explanation
:CONTROL
:SOURCE
:DRAIN

[Figure 2: Measurement Circuit] * This measurement circuit is used for ILIMIT measurement.

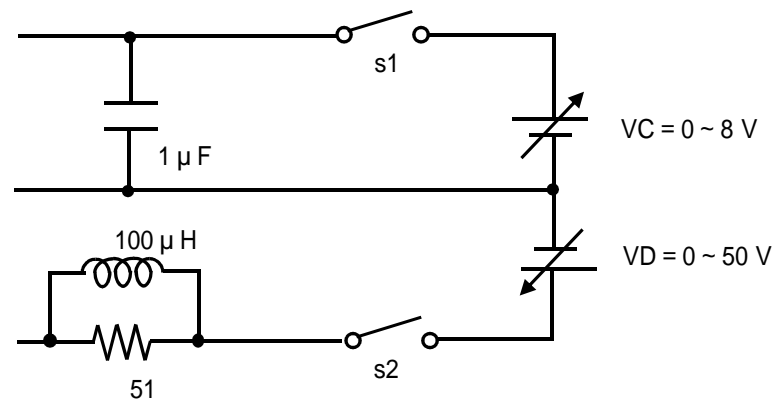

Terminal explanation
:CONTROL
:SOURCE
:DRAIN

[Figure 3: d_{fosc} , f_M Measurement Waveform]

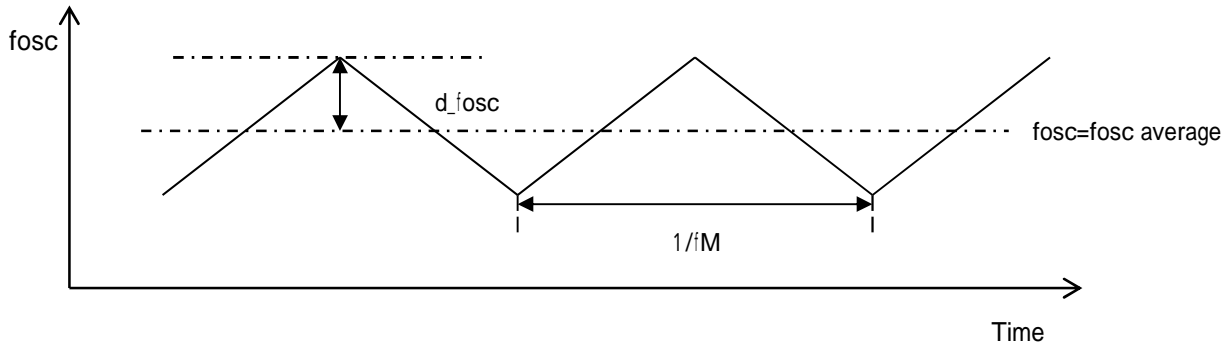

[Figure 4: TTSW, TTIM, f_{TIM} Measurement Waveform]

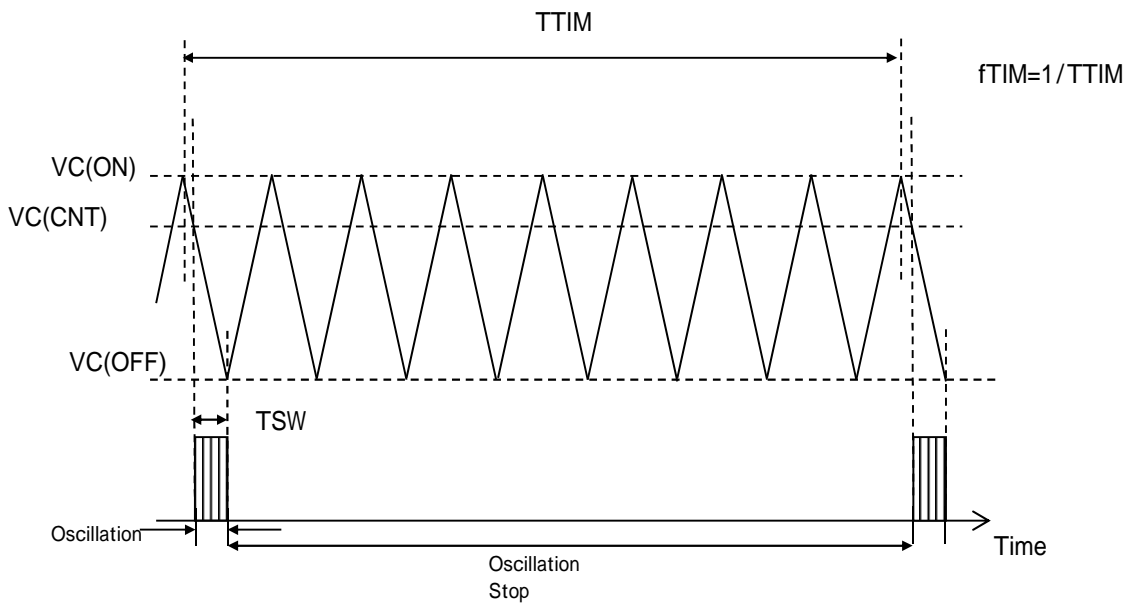

[Figure 5: VEAO Measurement]

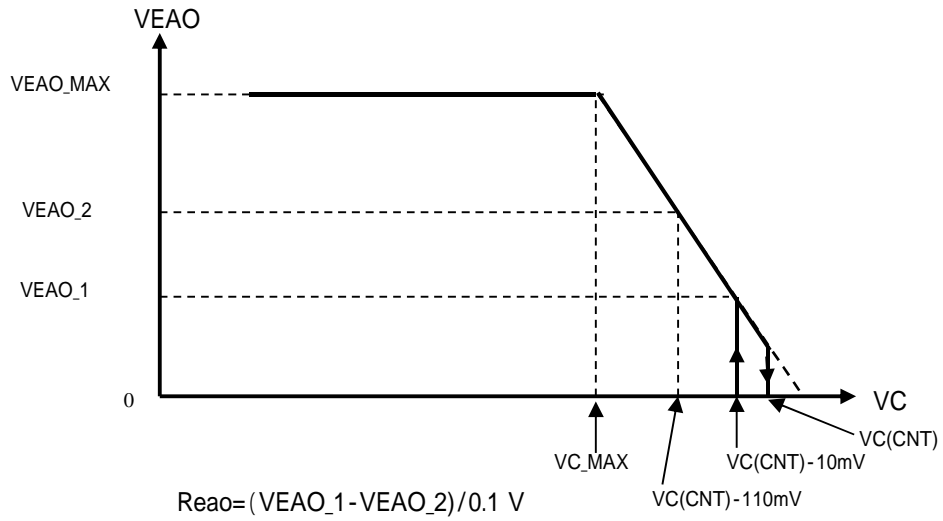

[Figure 6: ILIMIT Measurement]

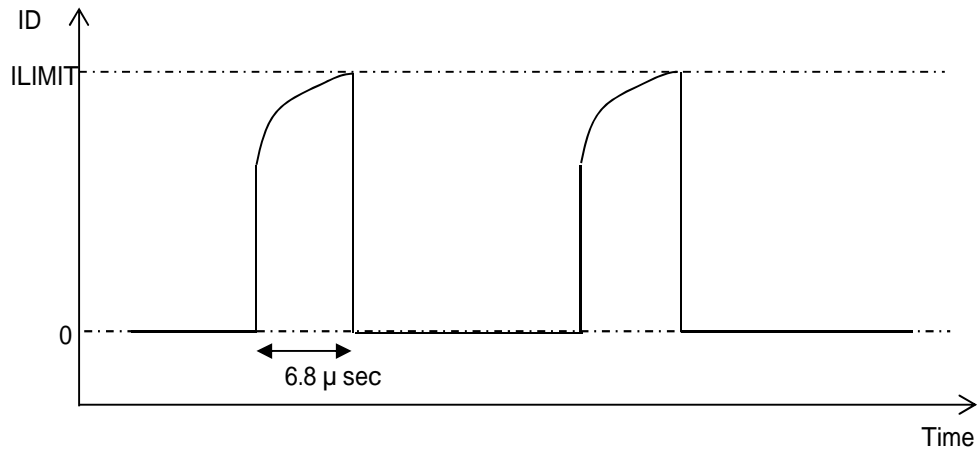

[Figure 7: tr, tf Measurement]

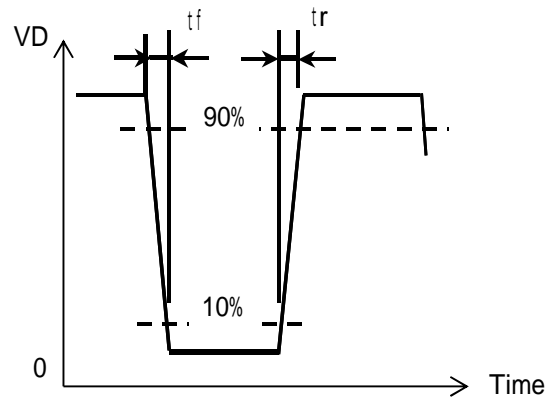

[Figure 8: Block Diagram]

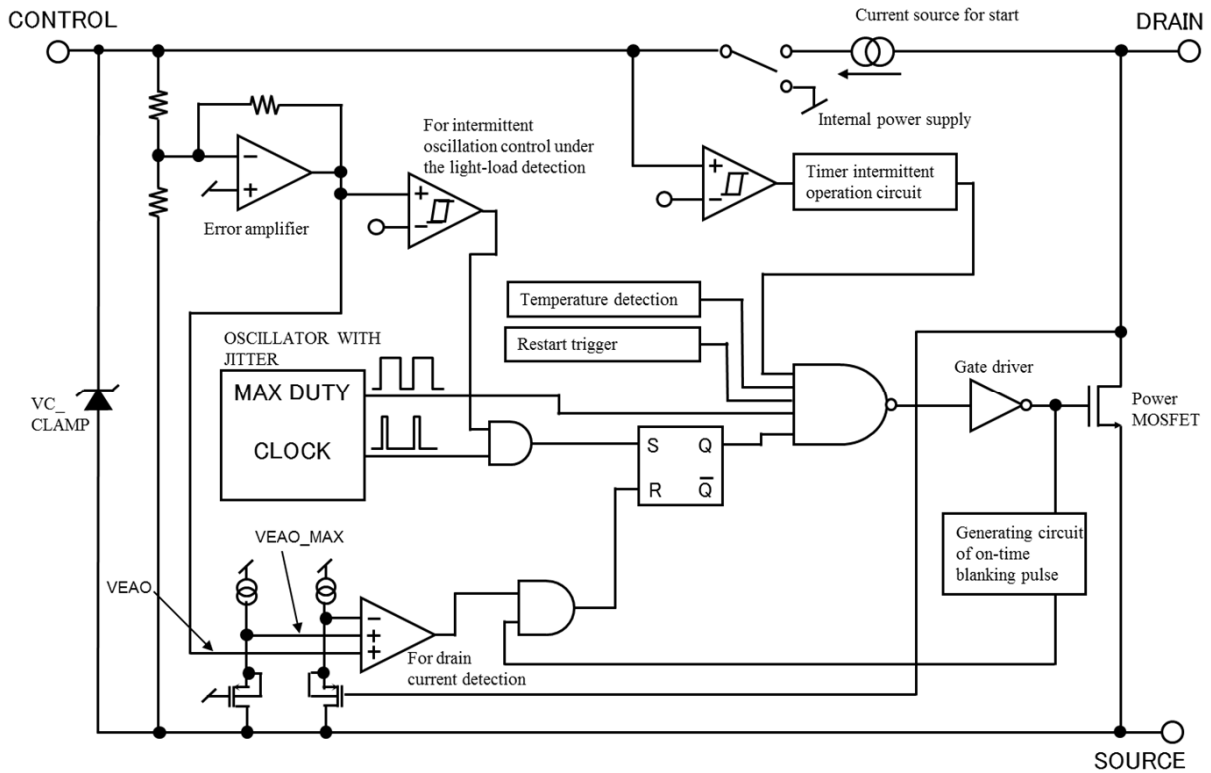

[Figure 9: Pin Layout]

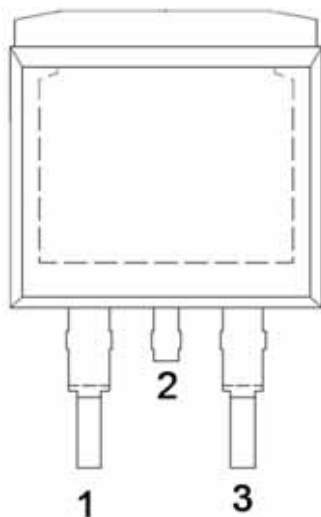

Pin No	Terminal Name
1	CONTROL
2	SOURCE
3	DRAIN

[Precautions for Use 1]

Connect a ceramic capacitor with value 0.1 μ F between CONTROL pin and SOURCE pin.

[Precautions for Use 2]

The product has risks for break-down or burst or giving off smoke in following conditions. Avoid the following use.
Fuse should be added at the input side or connect zener diode between CONTROL pin and SOURCE pin, etc. as a countermeas
to pass regulatory Safety Standard. Concrete countermeasure could be provided individually. However, customer should
make the final judgment.

(1) DRAIN pin short to CONTROL pin.

(2) DRAIN pin short to SOURCE pin.

Request for your special attention and precautions in using the technical information and semiconductors described in this book

- (1) If any of the products or technical information described in this book is to be exported or provided to non-residents, the laws and regulations of the exporting country, especially, those with regard to security export control, must be observed.
- (2) The technical information described in this book is intended only to show the main characteristics and application circuit examples of the products. No license is granted in and to any intellectual property right or other right owned by Panasonic Corporation, Nuvoton Technology Corporation Japan or any other company. Therefore, no responsibility is assumed by our company as to the infringement upon any such right owned by any other company which may arise as a result of the use of technical information de-scribed in this book.
- (3) The products described in this book are intended to be used for general applications (such as office equipment, communications equipment, measuring instruments and household appliances), or for specific applications as expressly stated in this book.
Please consult with our sales staff in advance for information on the following applications, moreover please exchange documents separately on terms of use etc.: Special applications (such as for in-vehicle equipment, airplanes, aerospace, automotive equipment, traffic signaling equipment, combustion equipment, medical equipment and safety devices) in which exceptional quality and reliability are required, or if the failure or malfunction of the products may directly jeopardize life or harm the human body.
Unless exchanging documents on terms of use etc. in advance, it is to be understood that our company shall not be held responsible for any damage incurred as a result of or in connection with your using the products described in this book for any special application.
- (4) The products and product specifications described in this book are subject to change without notice for modification and/or improvement. At the final stage of your design, purchasing, or use of the products, therefore, ask for the most up-to-date Product Standards in advance to make sure that the latest specifications satisfy your requirements.
- (5) When designing your equipment, comply with the range of absolute maximum rating and the guaranteed operating conditions (operating power supply voltage and operating environment etc.). Especially, please be careful not to exceed the range of absolute maximum rating on the transient state, such as power-on, power-off and mode-switching. Otherwise, we will not be liable for any defect which may arise later in your equipment.
Even when the products are used within the guaranteed values, take into the consideration of incidence of break down and failure mode, possible to occur to semiconductor products. Measures on the systems such as redundant design, arresting the spread of fire or preventing glitch are recommended in order to prevent physical injury, fire, social damages, for example, by using the products.
- (6) Comply with the instructions for use in order to prevent breakdown and characteristics change due to external factors (ESD, EOS, thermal stress and mechanical stress) at the time of handling, mounting or at customer's process. We do not guarantee quality for disassembled products or the product re-mounted after removing from the mounting board.
When using products for which damp-proof packing is required, satisfy the conditions, such as shelf life and the elapsed time since first opening the packages.
- (7) When reselling products described in this book to other companies without our permission and receiving any claim of request from the resale destination, please understand that customers will bear the burden.
- (8) This book may be not reprinted or reproduced whether wholly or partially, without the prior written permission of our company.

No.070920

单击下面可查看定价，库存，交付和生命周期等信息

[>>Panasonic\(松下\)](#)