

## **Notification about the transfer of the semiconductor business**

The semiconductor business of Panasonic Corporation was transferred on September 1, 2020 to Nuvoton Technology Corporation (hereinafter referred to as "Nuvoton"). Accordingly, Panasonic Semiconductor Solutions Co., Ltd. became under the umbrella of the Nuvoton Group, with the new name of Nuvoton Technology Corporation Japan (hereinafter referred to as "NTCJ").

In accordance with this transfer, semiconductor products will be handled as NTCJ-made products after September 1, 2020. However, such products will be continuously sold through Panasonic Corporation.

Publisher of this Document is NTCJ.

If you would find description "Panasonic" or "Panasonic semiconductor solutions", please replace it with NTCJ.

※ Except below description page

"Request for your special attention and precautions in using the technical information and semiconductors described in this book"

**Nuvoton Technology Corporation Japan**

種別/Type	シリコンMOS形集積回路/Silicon MOSFET Type Integrated Circuit		
用途/Application	スイッチング電源制御用/For Switching Power Supply Control		
構造/Structure	CMOS形/CMOS Type		
等価回路/Equivalent Circuit	添付図 1/See Figure 1		
外形/Out Line	DIP7-A1-B	マーク記号/マーキング/Marking	MIP414

**A. 絶対最大定格/Absolute Maximum Ratings (Ta=25°C±3°C)**

NO.	項目/Item	記号/Symbol	定格/Ratings	単位/Unit	備考/Note
1	ドレイン端子電圧 DRAIN Voltage	VD	-0.3 ~ 700	V	※1 下記パルス幅以内での保証とする。 The guarantee within the following pulse width. オン時ブランキング幅 ton(BLK) +過電流保護遅れ時間 td(OCL) Leading Edge Blanking Delay : ton(BLK) +Current Limit Delay : td(OCL)
2	VCC端子電圧 VCC Voltage	VCC	-0.3 ~ 45	V	
3	VDD端子電圧 VDD Voltage	VDD	-0.3 ~ 9	V	
4	FB端子電圧 FB Voltage	VFB	-0.3 ~ 6	V	
5	TR端子電圧 TR Voltage	VTR	-0.4 ~ 10	V	
6	ドレインピーク電流 Drain Peak Current	IDP	2.4(※1)	A	
7	チャネル部温度 Channel Temperature	Tch	150	°C	
8	保存温度 Storage Temperature	Tstg	-55 ~ 150	°C	

**B. 電気的特性/Electrical Characteristics**

**測定条件/Measure Condition (Tc=25°C±3°C)**

No.	項目/Item	記号/Symbol	測定条件/Measure Condition (測定図-1 参照/See Figure 1)	Typ.	Limit		Unit
					Min.	Max.	

【コントロール機能/Control Functions: \*は設計保証項目/Design Guarantee Item】

1	VDD基準電圧 VDD Voltage	VDD(REG)	VCC=15 V, IFB=-150 μA, TR=OPEN	5.9	5.4	6.4	V
2	VCC起動電圧 VCC Start Voltage	VCC(ON)	IFB=-150 μA, TR=OPEN	12.1	11.1	13.1	V
3	VCC停止電圧 VCC Stop Voltage	VCC(OFF)	IFB=-150 μA, TR=OPEN	7.7	6.7	8.7	V
4	VCC 起動/停止ヒステリシス電圧 VCC Auto-restart Hysteresis Voltage	VCCHYS	VCC(ON) - VCC(OFF)	4.4	3.4	5.4	V
5	回路消費電流 Supply Current	ICC	VCC=15 V, IFB=-150 μA	0.6	0.1	1.1	mA
6	起動前回路消費電流 Supply Current Before Start-up	ICC(SB)	VCC=VCC(ON)-0.2 V, FB,TR=OPEN	0.35	0.1	0.6	mA
7	フィードバック電流 Feedback Threshold Current	IFB1	ON → OFF VCC=15 V	-290	-350	-230	μA
8	フィードバック電流ヒステリシス Feedback Hysteresis Current	IFBHYS	VCC=15 V	4.0			μA

No.	項目/Item	記号/ Symbol	測定条件/Measure Condition (測定図-1 参照/See Figure 1)	Typ.	Limit		Unit
					Min.	Max.	
<b>【コントロール機能/Control Functions: *は設計保証項目/Design Guarantee Item】</b>							
9	FB端子電圧 FB Pin Voltage	VFB	VCC=15 V, IFB=-150 $\mu$ A, TR=OPEN	1.8	1.5	2.1	V
10	FB端子短絡電流 FB Pin Short-Circuit Current	IFB0	VCC=15 V, VFB=0 V, TR=OPEN	-490	-640	-340	$\mu$ A
11	軽負荷時回路消費電流 Supply Current at Light Load	ICC(OFF)	VCC=15 V, IFB=IFB1-5 $\mu$ A, TR=OPEN	0.85		1.35	mA
12	トランスリセット電圧 Trans Reset Voltage	VTH(TR)	VCC=15 V, IFB=-150 $\mu$ A	0	-0.1	0.1	V
*13	トランスリセット検出遅れ時間 Trans Reset Delay Time	td(TR)	VCC=15 V, IFB=-150 $\mu$ A	220			ns
*14	タイム間欠動作時間比 Auto-restart Duty Cycle	TSW/TTIM	FB=OPEN	13.5			%
*15	間欠動作周波数 Auto-restart Frequency	fTIM	FB=OPEN	0.68			Hz
16	VCC 充電電流 VCC Charging Current	ICCH1	VCC=0 V, VD=40 V, FB,VDD=OPEN	-3.7	-5.7	-1.7	mA
		ICCH2	VCC=10 V, VD=40 V, FB,VDD=OPEN	-1.3	-2.8	-0.5	
17	VDD充電電流 VDD Charging Current	IDCH1	VDD=0 V, VD=40 V, FB,VCC=OPEN	-3.3	-5.3	-1.3	mA
		IDCH2	VDD=5 V, VD=40 V, FB,VCC=OPEN	-1.8	-3.3	-0.5	
*18	ターンオフ後マスク時間 Mask Time after Turn-off	td(OFF)	VCC=15 V, IFB=-150 $\mu$ A	8.0			$\mu$ s
*19	間欠停止時TR検出時間 TR detection Time at Intermittent Mode	Toff(TR)	VCC=15 V	10.0			$\mu$ s
<b>【保護機能/Circuit Protections: *は設計保証項目/Design Guarantee Item】</b>							
20	過電流保護検出 Self Protection Current Limit	ILIMIT	VCC=15 V, FB=3 V <span style="float:right">※ Figure 2</span>	1.00	0.90	1.10	A
*21	軽負荷時ドレイン電流 Drain Current at Light Load	ID(OFF)	VCC=15 V, IFB=IFB1+IFBHYS	200			mA
*22	オン時ブランキング幅 Leading Edge Blanking Delay	ton(BLK)	VCC=15 V, VFB=3 V	500			ns
*23	過電流保護遅れ時間 Current Limit Delay	td(OCL)	VCC=15 V, VFB=3 V	150			ns
24	過電圧保護検出 Over Voltage Protection	VCC(OV)	IFB=-150 $\mu$ A	31.5	28.5	34.5	V
25	VDD 過電圧保護検出電流 VDD Over Voltage Protection Detection Current	IDD(OV)	VCC=15 V, IFB=-150 $\mu$ A	9.5	6.5	12.5	mA
26	VDD 端子クランプ電圧 VDD Clamp Voltage	VDD(OV)	VCC=15 V, IDD=IDD(OV), IFB=-150 $\mu$ A	6.6	VDD(REG)	7.6	V
27	過負荷保護検出FB電圧 Over Load Protection Detection FB Voltage	VFB(OL)	VCC=15 V, IFB < IFB(OL)	4.4	3.9	4.9	V
28	過負荷保護検出FB電流 Over Load Protection Detection FB Current	IFB(OL)	VCC=15 V, VFB=3.5 V	-62	-82	-42	$\mu$ A

No.	項目 / Item	記号 / Symbol	測定条件 / Measure Condition (測定図-1 参照 / See Figure 1)	Typ.	Limit		Unit																		
					Min	Max																			
<b>【保護機能 / Circuit Protections: *は設計保証項目 / Design Guarantee Item】</b>																									
29	最大オン時間 Maximum ON time	MAX(ON)	VD=5 V, VCC=15 V, FB=-150 $\mu$ A	25	18	32	$\mu$ s																		
*30	過熱保護温度 Thermal Shutdown Temperature	TOTP		140	130	150	$^{\circ}$ C																		
31	ラッチリセット電圧 Power-up Reset Threshold Voltage	VDDreset		2.7	1.7	3.7	V																		
<b>【出力部 / Output】</b>																									
32	オン抵抗 ON-State Resistance	RDS(ON)	VCC=15 V, ID=300 mA, VFB=3 V	4.9		6.7	$\Omega$																		
33	オフ時ドレイン端子リーク電流 Off-State Drain Pin Leakage Current	IDSS	VCC=35 V, VD=650 V, FB,TR=OPEN	6.0		20	$\mu$ A																		
34	ドレイン耐圧 Breakdown Voltage	VDSS	VCC=35 V, ID=100 $\mu$ A, FB,TR=OPEN		700		V																		
35	立ち上がり時間 Rise Time	tr	VCC=15 V, FB=-150 $\mu$ A, VD=5 V ※ Figure 3	80			ns																		
36	立ち下がり時間 Fall Time	tf	VCC=15 V, FB=-150 $\mu$ A, VD=5 V ※ Figure 3	40			ns																		
<b>【電源部 / SUPPLY VOLTAGE CHARACTERISTICS】</b>																									
37	最小ドレイン電圧 DRAIN Supply Voltage	VD(MIN)	VCC,FB,TR=OPEN		50		V																		
<b>【Figure 1: 測定回路図 / Measure Circuit】</b>																									
<p>※ VD、VTR の測定条件について、特に記述なき場合は、VD には、ILIMIT が機能する以上の電圧を印加し、VTR はパワー-MOSFET がオンできる状態とします。</p> <p>When there is especially no description about the measurement conditions of VD and VTR, VD is applied more than voltage which ILIMIT operate and VTR is taken as the state which Power MOSFET can be turned on.</p>																									
				<p>パワー-MOSFETオン信号 Power MOSFET ON Signal</p> <p>VTR</p> <p>0 V</p> <p>t</p>																					
<table border="1"> <thead> <tr> <th>PIN No.</th> <th>Pin Name</th> </tr> </thead> <tbody> <tr> <td>1</td> <td>VDD</td> </tr> <tr> <td>2</td> <td>FB</td> </tr> <tr> <td>3</td> <td>TR</td> </tr> <tr> <td>4</td> <td>VCC</td> </tr> <tr> <td>5</td> <td>DRAIN</td> </tr> <tr> <td>6</td> <td>-</td> </tr> <tr> <td>7</td> <td>SOURCE</td> </tr> <tr> <td>8</td> <td>SOURCE</td> </tr> </tbody> </table>		PIN No.	Pin Name	1	VDD	2	FB	3	TR	4	VCC	5	DRAIN	6	-	7	SOURCE	8	SOURCE						
PIN No.	Pin Name																								
1	VDD																								
2	FB																								
3	TR																								
4	VCC																								
5	DRAIN																								
6	-																								
7	SOURCE																								
8	SOURCE																								

【Figure 2: ILIMIT 測定/ILIMIT Measurement】

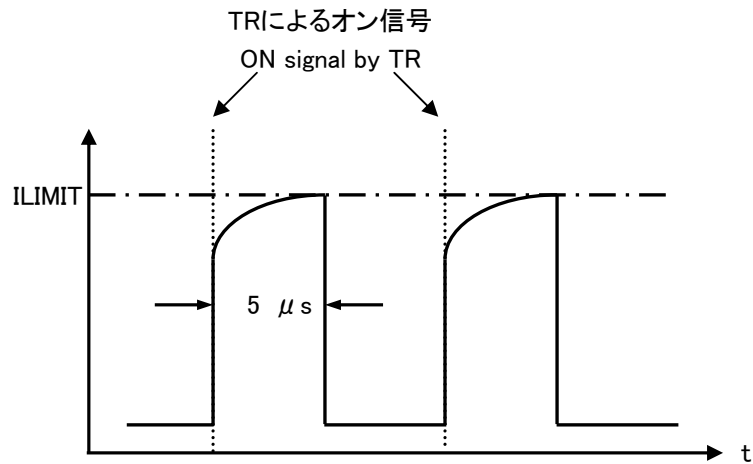

※ ILIMIT測定時のL,Rは、L=100  $\mu$ H、R=51  $\Omega$ です。  
L=100  $\mu$ H、R=51  $\Omega$  at ILIMIT Measurement

【Figure 3: tr, tf 測定/tr, tf Measurement】

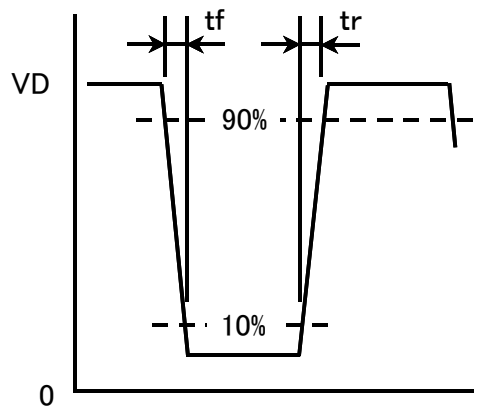

【Fig. 4: ブロック図/Block Diagram】

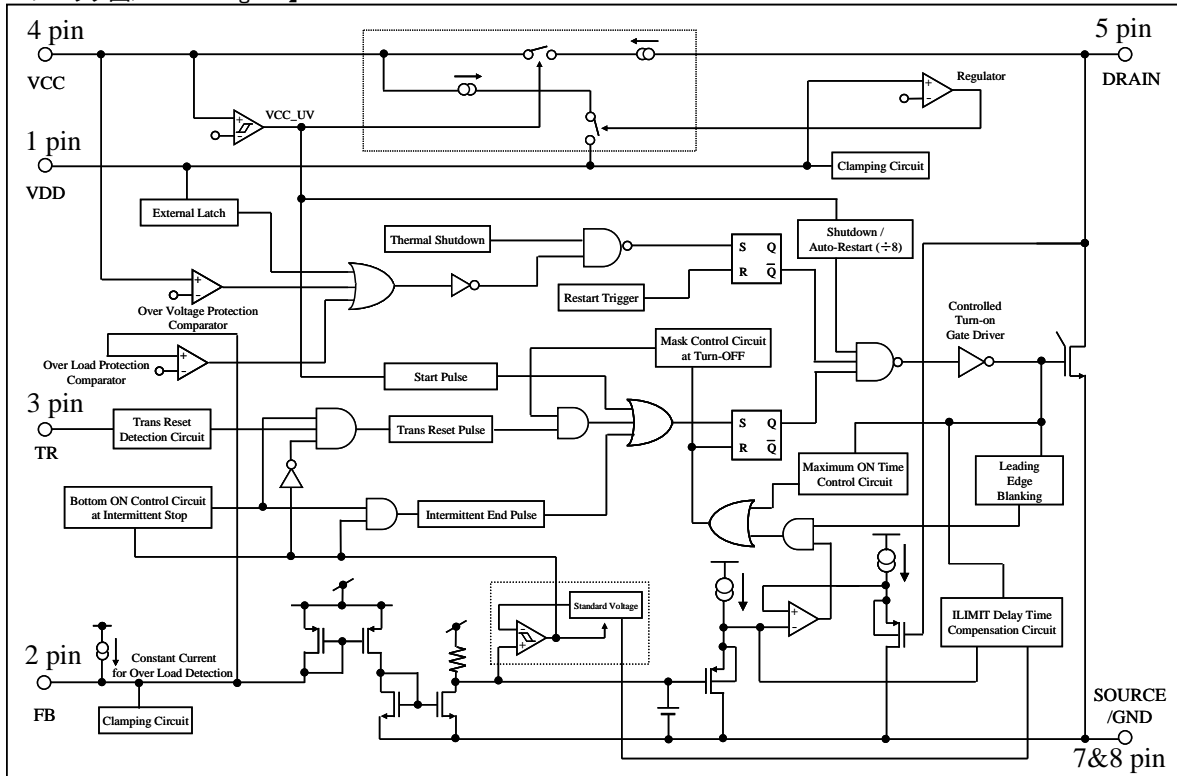

【使用上の注意1/Precautions for Use 1】

VDD-SOURCE 間には、必ず端子のすぐ近くに(0.1  $\mu$ F 以上の)セラミックコンデンサを接続して下さい。  
Connect a Ceramic Capacitor(over 0.1  $\mu$ F) between VDD and SOURCE.

【使用上の注意2/Precautions for Use 2】

VCC 端子に接続する電解コンデンサのオープン試験に対する二次側出力上昇の保護として、VCC-SOURCE 間に 0.1 $\mu$ F 以上のセラミックコンデンサを接続することを推奨します。  
Connect a Ceramic Capacitor over 0.1 $\mu$ F between VCC and SOURCE as protection of a secondary side OUTPUT rise against the open test of the electrolytic capacitor connected to VCC pin

【使用上の注意3/Precautions for Use 3】

以下のような使用条件では、IPDが破損し、場合によっては破裂、発煙の可能性があります。以下の使用は避けてください。  
IPD has danger of breaking-down, and then bursting or getting off smoke under the use of the following conditions.  
Do not use at such conditions.

- (1) DRAIN 端子と VDD 端子を逆にして、電源基板へ挿入する。  
Reverse the DRAIN pin and VDD pin connection to the power supply board.
- (2) DRAIN 端子と VDD 端子をショートする。 / DRAIN pin short to VDD pin.
- (3) DRAIN 端子と FB 端子をショートする。 / DRAIN pin short to FB pin.
- (4) DRAIN 端子と TR 端子をショートする。 / DRAIN pin short to TR pin.
- (5) DRAIN 端子と VCC 端子をショートする。 / DRAIN pin short to VCC pin.
- (6) VCC 端子と VDD 端子をショートする。 / VCC pin short to VDD pin.
- (7) VCC 端子と FB 端子をショートする。 / VCC pin short to FB pin.
- (8) VCC 端子と TR 端子をショートする。 / VCC pin short to TR pin.

## Request for your special attention and precautions in using the technical information and semiconductors described in this book

- (1) If any of the products or technical information described in this book is to be exported or provided to non-residents, the laws and regulations of the exporting country, especially, those with regard to security export control, must be observed.
- (2) The technical information described in this book is intended only to show the main characteristics and application circuit examples of the products. No license is granted in and to any intellectual property right or other right owned by Panasonic Corporation, Nuvoton Technology Corporation Japan or any other company. Therefore, no responsibility is assumed by our company as to the infringement upon any such right owned by any other company which may arise as a result of the use of technical information de-scribed in this book.
- (3) The products described in this book are intended to be used for general applications (such as office equipment, communications equipment, measuring instruments and household appliances), or for specific applications as expressly stated in this book.  
Please consult with our sales staff in advance for information on the following applications, moreover please exchange documents separately on terms of use etc.: Special applications (such as for in-vehicle equipment, airplanes, aerospace, automotive equipment, traffic signaling equipment, combustion equipment, medical equipment and safety devices) in which exceptional quality and reliability are required, or if the failure or malfunction of the products may directly jeopardize life or harm the human body.  
Unless exchanging documents on terms of use etc. in advance, it is to be understood that our company shall not be held responsible for any damage incurred as a result of or in connection with your using the products described in this book for any special application.
- (4) The products and product specifications described in this book are subject to change without notice for modification and/or improvement. At the final stage of your design, purchasing, or use of the products, therefore, ask for the most up-to-date Product Standards in advance to make sure that the latest specifications satisfy your requirements.
- (5) When designing your equipment, comply with the range of absolute maximum rating and the guaranteed operating conditions (operating power supply voltage and operating environment etc.). Especially, please be careful not to exceed the range of absolute maximum rating on the transient state, such as power-on, power-off and mode-switching. Otherwise, we will not be liable for any defect which may arise later in your equipment.  
Even when the products are used within the guaranteed values, take into the consideration of incidence of break down and failure mode, possible to occur to semiconductor products. Measures on the systems such as redundant design, arresting the spread of fire or preventing glitch are recommended in order to prevent physical injury, fire, social damages, for example, by using the products.
- (6) Comply with the instructions for use in order to prevent breakdown and characteristics change due to external factors (ESD, EOS, thermal stress and mechanical stress) at the time of handling, mounting or at customer's process. We do not guarantee quality for disassembled products or the product re-mounted after removing from the mounting board.  
When using products for which damp-proof packing is required, satisfy the conditions, such as shelf life and the elapsed time since first opening the packages.
- (7) When reselling products described in this book to other companies without our permission and receiving any claim of request from the resale destination, please understand that customers will bear the burden.
- (8) This book may be not reprinted or reproduced whether wholly or partially, without the prior written permission of our company.

No.070920

单击下面可查看定价，库存，交付和生命周期等信息

[>>Panasonic\(松下\)](#)