

Notification about the transfer of the semiconductor business

The semiconductor business of Panasonic Corporation was transferred on September 1, 2020 to Nuvoton Technology Corporation (hereinafter referred to as "Nuvoton"). Accordingly, Panasonic Semiconductor Solutions Co., Ltd. became under the umbrella of the Nuvoton Group, with the new name of Nuvoton Technology Corporation Japan (hereinafter referred to as "NTCJ").

In accordance with this transfer, semiconductor products will be handled as NTCJ-made products after September 1, 2020. However, such products will be continuously sold through Panasonic Corporation.

Publisher of this Document is NTCJ.

If you would find description "Panasonic" or "Panasonic semiconductor solutions", please replace it with NTCJ.

※ Except below description page

"Request for your special attention and precautions in using the technical information and semiconductors described in this book"

Nuvoton Technology Corporation Japan

Type	Silicon MOSFET type Integrated Circuit		
Application	For Switching Power Supply Control		
Structure	Bi-CMOS type		
Equivalent Circuit	Figure 7		
Package	DIP7-A1-B	Marking	MIP6T20

A. ABSOLUTE MAXIMUM RATINGS (Ta=25°C±3°C)

No.	Item	Symbol	Ratings	Unit	Note
1	DRAIN Voltage	DRAIN	-0.3 ~ 700	V	
2	DRAIN Peak Current	IDP	6	A	
3	VCC Voltage	VCC	-0.3 ~ 45	V	
4	VDD Voltage	VDD	-0.3 ~ 10	V	
5	LS Voltage	VLS	-0.3 ~ 10	V	
6	IS Voltage	VIS	-0.3 ~ 5	V	
7	FB Voltage	VFB	-0.3 ~ 8	V	
8	Junction Temperature	Tj	150	°C	Control IC & Power MOSFET
9	Storage Temperature	Tstg	-55 ~ +150	°C	

B. RECOMMENDED OPERATING CONDITIONS

No.	Item	Symbol	Conditions	Unit	Note
1	Junction Temperature (Control IC)	Tjcon	-40 ~ +125	°C	
2	Junction Temperature (Power MOSFET)	Tjmos	-40 ~ +150	°C	
3	VCC Operation Voltage	VCC	13 ~ 28	V	

C. ELECTRICAL CHARACTERISTICS Measurement condition (Ta=25°C±3°C)

No.	Item	Symbol	Measurement Conditions (Refer to figure 1)	Typ.	Min.	Max.	Unit
【CONTROL FUNCTIONS】 *Design Guarantee Item, **Reference Item							
1	VCC Start Voltage	VCC(ON)		18.5	16.5	20.5	V
2	VCC Stop Voltage	VCC(OFF)		10.8	9.8	11.8	V
3	VCC Start/Stop Hysteresis	D_VCC	VCC(ON) - VCC(OFF)	7.7	6.9	8.8	V
4	VDD Reference Voltage	VDDreg	VCC = 21 V	5.9	5.6	6.2	V
5	VCC Pin Current before Start-up	ICC(SB)	VCC = VCC(ON) - 0.8 V, FB = open	0.43	0.30	0.56	mA
**6	VCC Pin Current at Standby Mode	ICC(STB)	VCC = 15 V, IFB = IFB1 - 10 μA	0.54	-	-	mA
**7	VCC Pin Current at Light Load PWM	ICC(OP)L	VCC = 15 V, IFB = IFB1 + 5 μA, VDRAIN = 5 V	1.5	-	-	mA
**8	VCC Pin Current at Heavy Load PWM	ICC(OP)H	VCC = 15 V, IFB = -20 μA, VDRAIN = 5 V	2.20	-	2.62	mA
9	VCC Pin Current at Over Load Protection	ICC(OL)	VCC = 15 V VFB = VFB(OL) → open	0.43	0.30	0.56	mA
10	Switching Frequency at Light Load PWM	f(PWM)L	VCC = 21 V, IFB = IFB1 + 5 μA, VDRAIN = 5 V *Refer Figure 3	25	20	30	kHz
11	Switching Frequency at Heavy Load PWM	f(PWM)H	VCC = 21 V, IFB = -20 μA, VDRAIN = 5 V *Refer Figure 3	66	61.4	70.6	kHz
**12	Frequency Jitter Deviation at Light Load PWM	d_f(PWM)L	VCC = 21 V, IFB = IFB1 + 5 μA, VDRAIN = 5 V *Refer Figure 2	1.13	-	-	kHz
13	Frequency Jitter Deviation at Heavy Load PWM	d_f(PWM)H	VCC = 21 V, IFB = -20 μA, VDRAIN = 5 V *Refer Figure 2	3.0	1.8	4.2	kHz
**14	Frequency Jitter Modulation Rate	fM	VCC = 21 V, IFB = -20 μA, VDRAIN = 5 V *Refer Figure 2	450	-	-	Hz
15	Maximum Duty Cycle	MAXDC	VCC = 21 V, IFB = IFB3 + 3 μA, VDRAIN = 5 V	66	61	71	%
16	Feedback Current	IFB1	ON → OFF, VCC = 21 V, VDRAIN = 5V	-85	-110	-60	μA
**17	Feedback Current Hysteresis	IFBHYS	OFF → ON, VCC = 21 V, VDRAIN = 5V	3	-	-	μA
**18	Feedback Current at Light Load PWM	IFB2	VCC = 21 V, VDRAIN = 5V *Refer Figure 3	-60	-	-	μA
**19	Feedback Current at Heavy Load PWM	IFB3	VCC = 21 V, VDRAIN = 5V *Refer Figure 3	-50	-	-	μA
**20	Feedback Current at Maximum Output	IFB4	VCC = 21 V, VDRAIN = 5V *Refer Figure 3	-46	-	-	μA

No.	Item	Symbol	Measurement Conditions (Refer to figure 1)	Typ.	Min.	Max.	Unit
21	FB Pin Voltage at Light Load	VFB1	VCC = 21 V, IFB = IFB1	1.6	1.4	1.8	V
22	FB Pin Voltage at Heavy Load	VFB3	VCC = 21 V, IFB = IFB3	1.7	1.5	1.9	V
23	FB Pin Grounded Current	IFB0	VCC = 21 V, VFB = 0 V	-330	-450	-210	μA
24	FB Pin Pull-Down Resistance at Output Stop	RFB(OFF)	VCC = 40 V, VFB = VFB1	400	250	550	Ω
25	VCC Pin Charging Current	ICCH1	VCC = 0 V, FB = open, VLS = 2 V, VDRAIN = 50 V	-11.0	-15.4	-6.6	mA
		ICCH2	VCC = VCC(ON) - 0.5 V, FB = open, VLS = 2 V, VDRAIN = 50 V	-3.9	-5.6	-2.2	mA
*26	Soft Start Time	T _{soft}	VDRAIN = 50 V, VFB = 3V	6.0	3.5	8.5	ms
【CIRCUIT PROTECTIONS】 *Design Guarantee Item, **Reference Item							
27	Over Current Detection Voltage	VLIMIT	VCC = 21 V, VFB = 3 V, Ton = 4 μs *Refer Figure 4	790	734	846	mV
28	Over Current Detection Voltage 2	VLIMIT2	VCC = 21 V, VFB = 3 V, Ton = 2 μs *Refer Figure 4	775	705	-	mV
29	Over Current Detection Reference Voltage During Blanking Delay	VLIM(BLK)	VCC = 21 V, VFB = 3 V, VDRAIN = 5 V	1.90	1.65	-	V
**30	Leading Edge Blanking Delay	Ton(BLK)	VCC = 21 V, IFB = IFB3 + 3 μA, VIS = 1.5 V, VDRAIN = 5 V	330	-	-	ns
**31	Over Current Detection Delay	Td(OCL)	VCC = 21 V, VFB = 3 V	270	-	-	ns
**32	Peak Current Detection Voltage at PFM	VIS(PFM)	VCC = 21 V, IFB = IFB2 + 5 μA, Ton = 4 μs	710	-	-	mV
**33	Peak Current Detection Reference Voltage at Intermittent Stop	VIS(OFF)	VCC = 21 V, IFB = IFB1, VDRAIN = 5 V	120	-	-	mV
**34	Peak Current Detection Reference Voltage at Intermittent Recovery	VIS(OFF)H	VCC = 21 V, IFB = IFB1 + IFBHYS, VDRAIN = 5 V	240	-	-	mV
**35	Peak Current Detection Voltage Jitter Deviation	D_VIS	VCC = 21 V, IFB = IFB2 + 5 μA, VDRAIN = 5 V	24	-	-	mV
*36	Slope Compensation Rate	VIS_SLP	VCC = 21 V, IFB = IFB2 + 5 μA, VDRAIN = 5 V	-19.5	-24.0	-14.5	mV/μs
37	Over Load Detection Voltage	VFB(OL)	VCC = 21 V, VDRAIN = 5 V	4.4	4.1	4.7	V
38	FB Pin Current at Over Load	IFB(OL)	VCC = 21 V, VFB = 3 V, VDRAIN = 5 V	-10.0	-13.0	-7.5	μA
**39	Over Load Detection Filter Time	Td(OL)	VCC = 21 V, VDRAIN = 5 V	20	-	-	μs
40	IS Pin Short Detection Reference Voltage	VIS(IST)	VCC = 21 V, IFB = IFB1 + 5 μA, VDRAIN = 5 V	50	-	100	mV

No.	Item	Symbol	Measurement Conditions (Refer to figure 1)	Typ.	Min.	Max.	Unit
**41	IS Pin Short Detection On Time	Ton(IST)	VCC = 21 V, IFB = IFB1 + 5 μ A, VIS = 0V, VDRAIN = 5 V	3	-	-	μ s
42	VCC Pin Over Voltage Detection Voltage	VCC(OV)	VFB = 3 V, VDRAIN = 5 V	31.5	28.5	34.5	V
**43	VCC Pin Over Voltage Detection Filter Time	Td(VCCOV)		150	-	-	μ s
44	VCC Charge and Discharge Cycle at Timer Intermittent Operation	COUNT	VCC = VCC(ON) \leftrightarrow VCC(OFF) *Refer Figure 5	4			-
45	VDD Pin Latch Stop Detection Voltage	VDD(OV)	VCC = 21 V, VFB = 3 V, VDRAIN = 5 V	7.55	7.00	8.10	V
46	VDD Pin Latch Stop Detection Current	IDD(OV)	VCC = 21 V, VFB = 3 V, VDRAIN = 5 V	1.6	0.9	2.3	mA
47	VDD Pin Clamp Current	IDD(GLP)	VDD = 10 V	16.5	13.2	19.8	mA
**48	VDD Pin Latch Stop Detection Filter Time	Td(VDDOV)	VCC = 21 V, VFB = 3 V, VDRAIN = 5 V	150	-	-	μ s
49	VDD Pin Reset Voltage	VDDreset		2.7	1.7	3.7	V
*50	Thermal Shutdown Temperature (Control IC)	TOTP		140	130	150	$^{\circ}$ C
**51	Thermal Shutdown Temperature Hysteresis (Control IC)	TOTPHYS		45	-	-	$^{\circ}$ C
52	LS Pin Over Voltage Detection Voltage	VLS(OV)	VCC = 21 V, VFB = 3 V, VDRAIN = 5 V	4.40	4.15	4.65	V
53	LS Pin Over Voltage Release Voltage	VLS(OV)L	VCC = 21 V, VFB = 3 V, VDRAIN = 5 V	4.18	3.93	4.43	V
**54	LS Pin Over Voltage Detection/Release Voltage Hysteresis	D_VLSOV	VCC = 21 V, VFB = 3 V, VDRAIN = 5 V	0.22	-	-	V
55	DRAIN Pin Current at LS Pin Over Voltage Detection	ID(LSOV)	VCC = open, VFB = 3 V, VLS = 5 V, VDRAIN = 50 V	2.8	1.8	3.8	mA
**56	LS Pin Over Voltage Detection Filter Time	Td(LSOV)	VCC = 21 V, VFB = 3 V, VDRAIN = 5 V	50	-	-	μ s
57	LS Pin Under Voltage Detection Voltage	VLS(UV)	VCC = 21 V, VFB = VFB(OL) \rightarrow 3V, VDRAIN = 5 V	0.73	0.66	0.80	V
58	LS Pin Under Voltage Release Voltage	VLS(UV)H	VCC = 21 V, VFB = VFB(OL) \rightarrow 3V, VDRAIN = 5 V	0.81	0.73	0.89	V
**59	LS Pin Under Voltage Detection/Release Voltage Hysteresis	D_VLSUV	VCC = 21 V, VFB = VFB(OL) \rightarrow 3V, VDRAIN = 5 V	0.08	-	-	V
**60	LS Pin Under Voltage Detection Filter Time	Td(LSUV)	VCC = 21 V, VFB = VFB(OL) \rightarrow 3V, VDRAIN = 5 V	50	-	-	μ s
61	LS Pin Disable Detection Voltage	VLS(DIS)	VCC = 21 V, VFB = VFB(OL) \rightarrow 3V, VDRAIN = 5 V	0.10	0.05	0.15	V

No.	Item	Symbol	Measurement Conditions (Refer to figure 1)	Typ.	Min.	Max.	Unit
【POWER MOSFET】 *Design Guarantee Item, **Reference Item							
62	Minimum DRAIN Pin Voltage	VD(MIN)	IFB = -20 μ A, VLS = 2 V ※DRAIN voltage when oscillation start	25	20	29	V
63	DRAIN Pin Breakdown Voltage	VDSS	VCC = 40 V, IDRAIN = 250 μ A,	-	700	-	V
64	DRAIN Pin Leakage Current	IDSS	VCC = 40 V, VDRAIN = 650 V	2	-	7	μ A
65	ON-State Resistance	RDS(ON)	VCC = 21 V, VFB = 3 V, IDRAIN = 1.0 A	1.35	-	1.70	Ω
**66	Rise Time	tr	VCC = 21 V, VFB = 3 V, VDRAIN = 5 V *Refer Figure 6	180	-	-	ns
**67	Fall Time	tf	VCC = 21 V, VFB = 3 V, VDRAIN = 5 V *Refer Figure 6	90	-	-	ns

【Figure 1: Measurement circuit/Pin Layout】

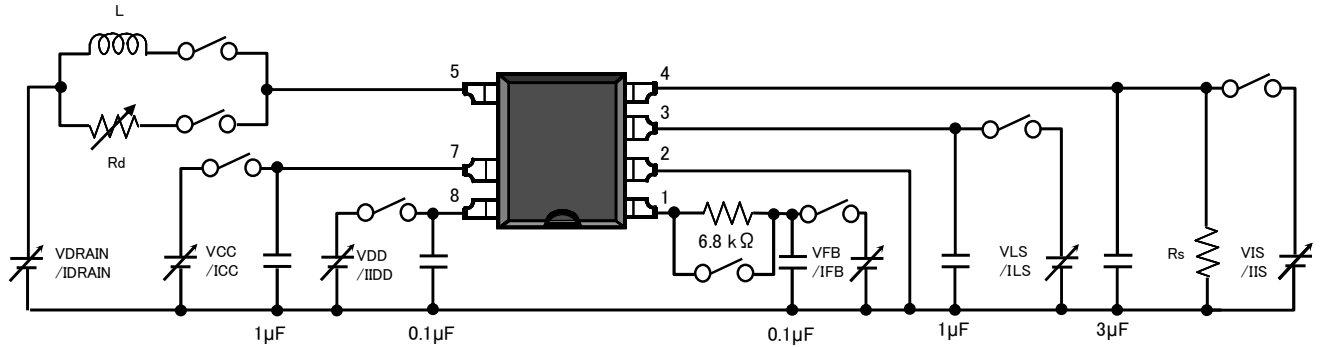

Pin No.	Pin Name	Function
1	FB	Feedback control, Over Load Detection
2	GND	Control Ground
3	LS	Input Over Voltage detection / Over load protection deactivation when input Under Voltage detection
4	IS	Power MOSFET Source / Over Current Detection
5	DRAIN	Power MOSFET Drain / Start-up current supply
6	-	-
7	VCC	Power supply from bias winding / Over Voltage Detection
8	VDD	Internal circuit power supply voltage / External Latch-Stop function

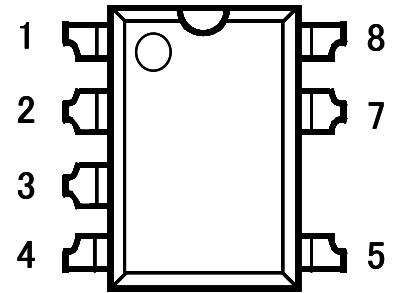

【Figure 2: Switching frequency & jitter deviation (fosc & d_fosc), frequency jitter modulation rate (fM) characteristics】

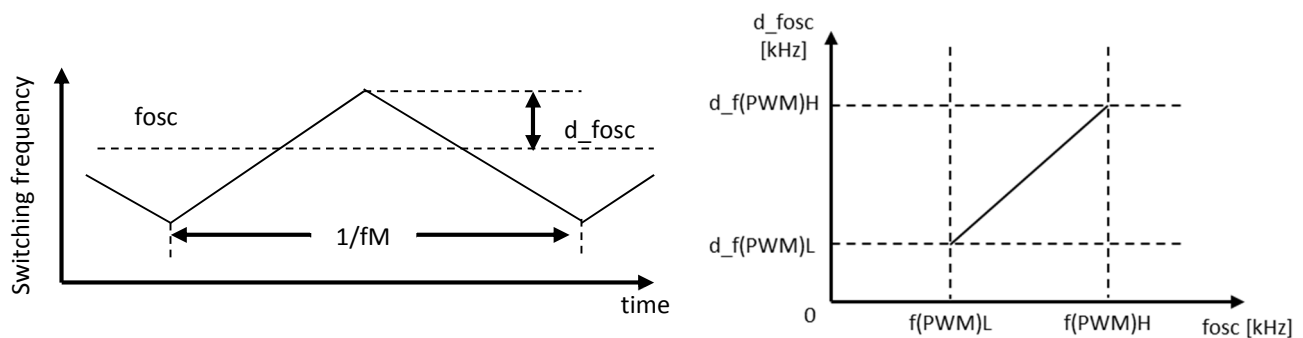

【Figure 3: IS pin detection voltage-IFB Characteristic、Switching frequency-IFB Characteristic】

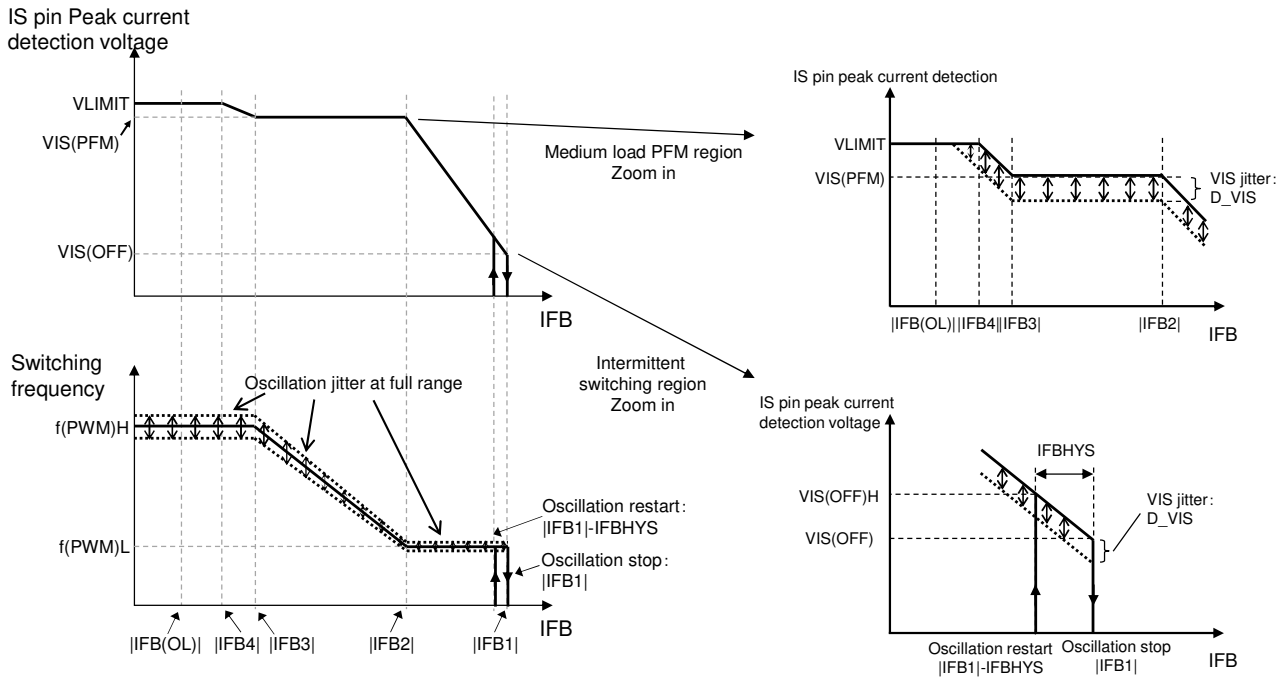

【Figure 4: IS pin detection voltage - ON time dependency】

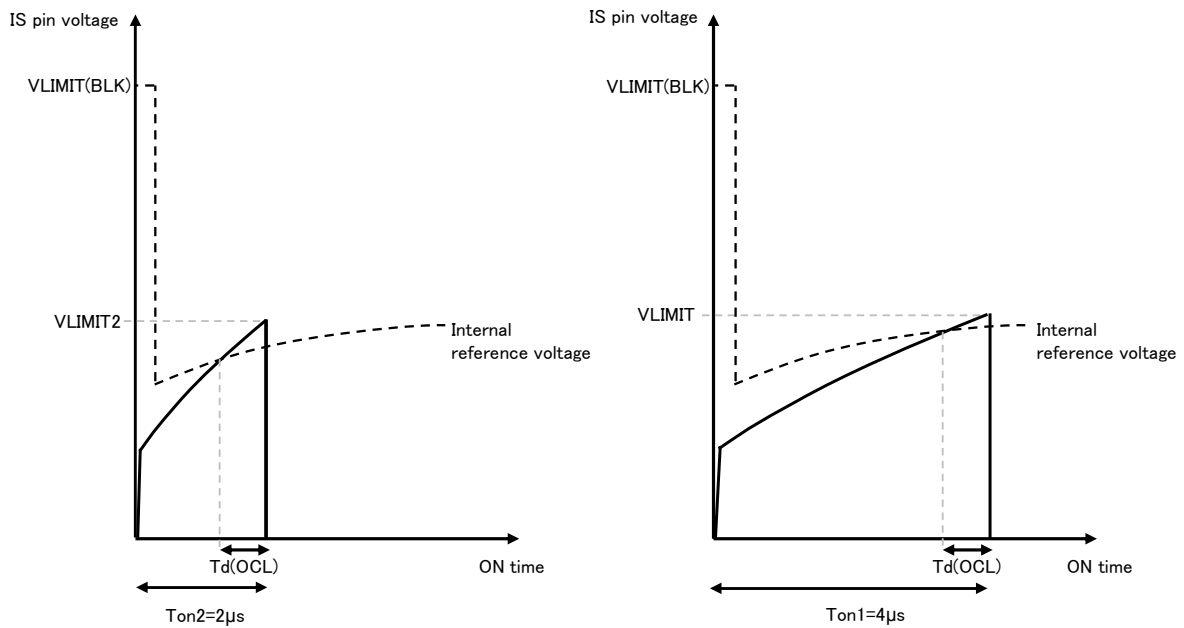

※Drain pin load for VLIMIT & VLIMIT2 measurement: L=100 µH, Rd=51 Ω

【Figure 5: Over Load Protection Characteristics】

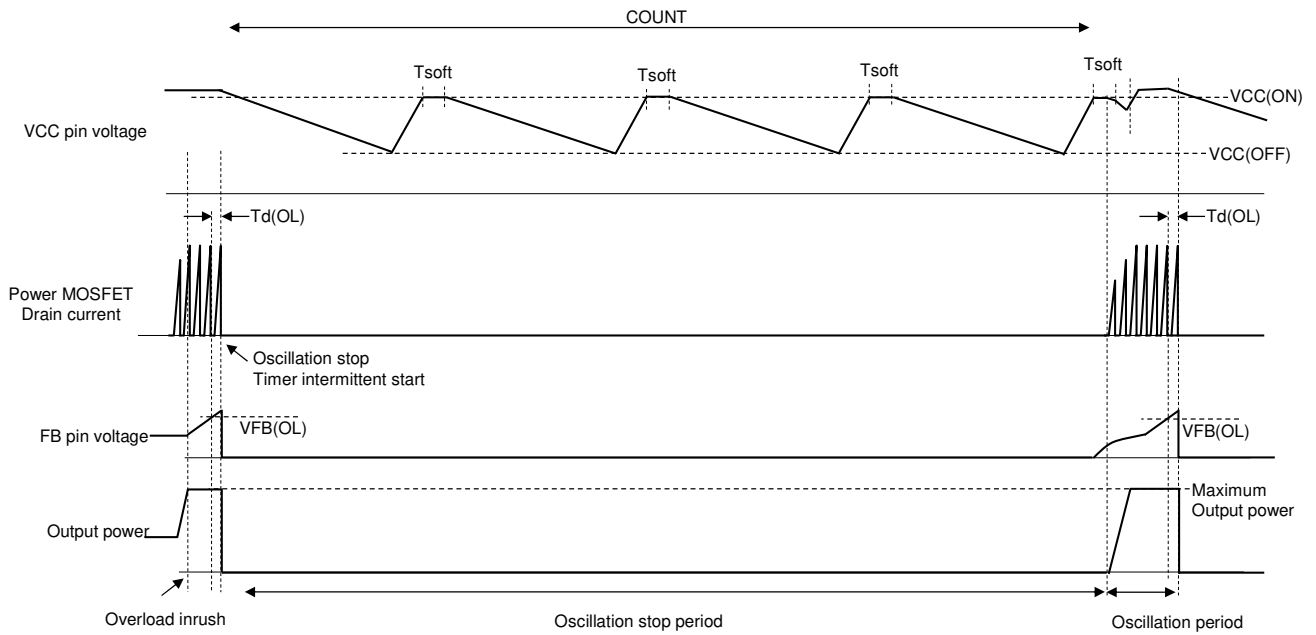

【Figure 6: tr, tf measurement】

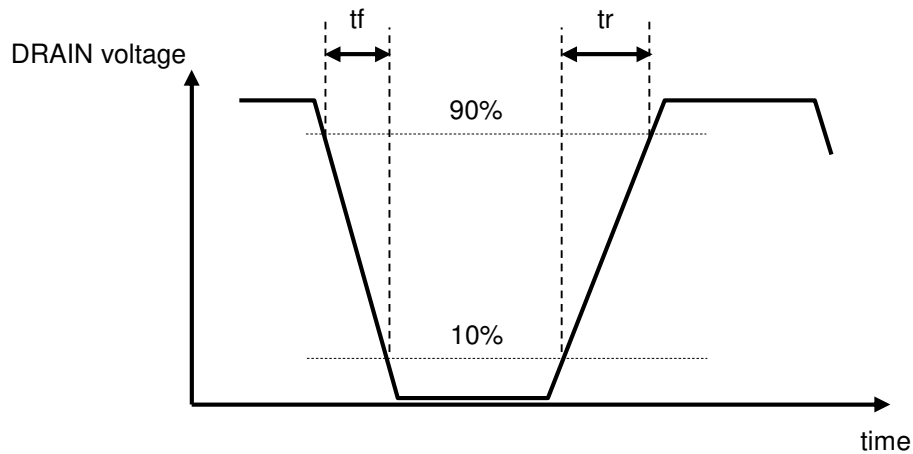

【Figure 7: Block Diagram】

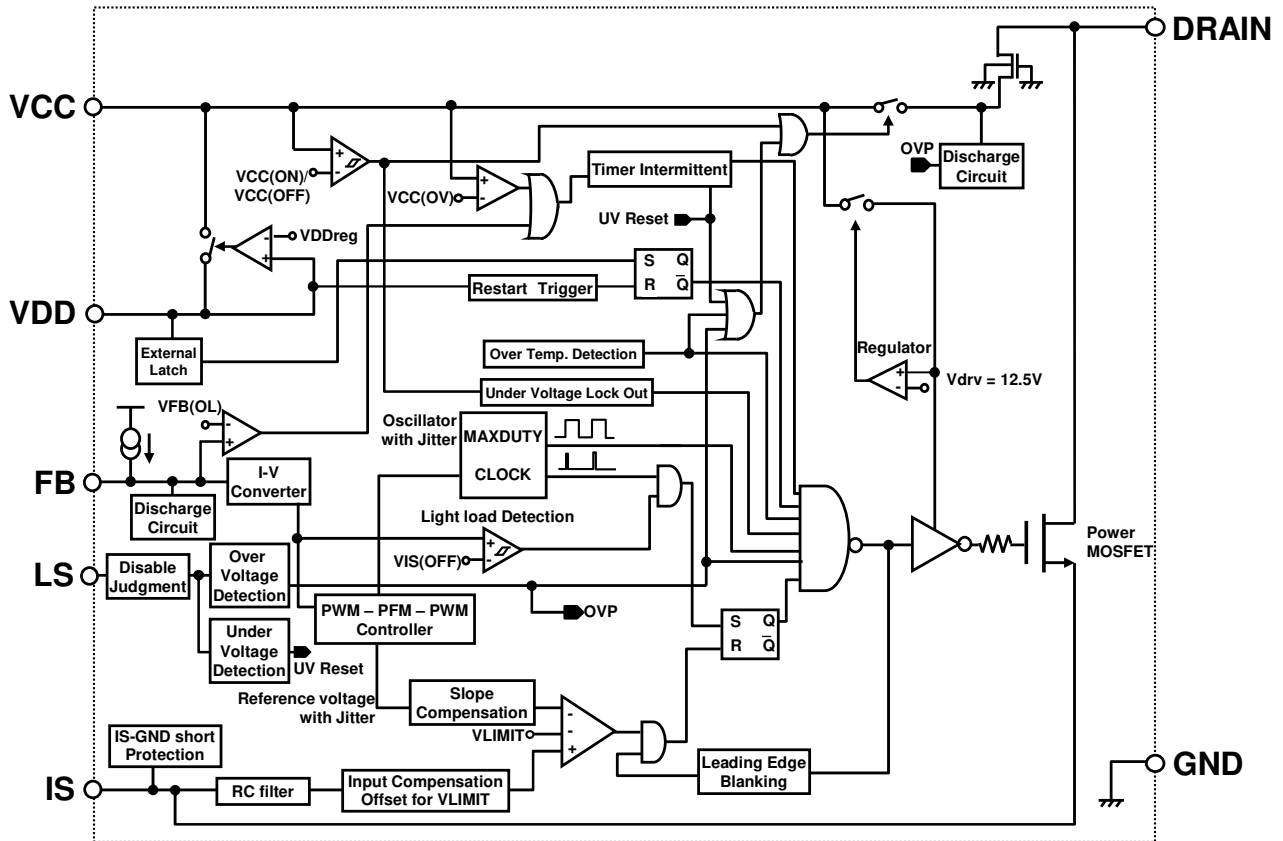

【Precautions for Use 1】

Connect a ceramic capacitor with value $\geq 0.1 \mu\text{F}$ between VDD pin and GND

【Precautions for Use 2】

The product has risks for break-down or burst or giving off smoke in following conditions. Avoid the following use.
Fuse should be added at the input side or connect zener diode between control pin and GND, etc as a countermeasure to pass regulatory Safety Standard. Concrete countermeasure could be provided individually. However, customer should make the final judgment.

- (1) Reverse the Drain pin and FB pin connection to the power supply board.
- (2) Connect to pins in which different Maximum ratings.

Request for your special attention and precautions in using the technical information and semiconductors described in this book

- (1) If any of the products or technical information described in this book is to be exported or provided to non-residents, the laws and regulations of the exporting country, especially, those with regard to security export control, must be observed.
- (2) The technical information described in this book is intended only to show the main characteristics and application circuit examples of the products. No license is granted in and to any intellectual property right or other right owned by Panasonic Corporation, Nuvoton Technology Corporation Japan or any other company. Therefore, no responsibility is assumed by our company as to the infringement upon any such right owned by any other company which may arise as a result of the use of technical information de-scribed in this book.
- (3) The products described in this book are intended to be used for general applications (such as office equipment, communications equipment, measuring instruments and household appliances), or for specific applications as expressly stated in this book.
Please consult with our sales staff in advance for information on the following applications, moreover please exchange documents separately on terms of use etc.: Special applications (such as for in-vehicle equipment, airplanes, aerospace, automotive equipment, traffic signaling equipment, combustion equipment, medical equipment and safety devices) in which exceptional quality and reliability are required, or if the failure or malfunction of the products may directly jeopardize life or harm the human body.
Unless exchanging documents on terms of use etc. in advance, it is to be understood that our company shall not be held responsible for any damage incurred as a result of or in connection with your using the products described in this book for any special application.
- (4) The products and product specifications described in this book are subject to change without notice for modification and/or improvement. At the final stage of your design, purchasing, or use of the products, therefore, ask for the most up-to-date Product Standards in advance to make sure that the latest specifications satisfy your requirements.
- (5) When designing your equipment, comply with the range of absolute maximum rating and the guaranteed operating conditions (operating power supply voltage and operating environment etc.). Especially, please be careful not to exceed the range of absolute maximum rating on the transient state, such as power-on, power-off and mode-switching. Otherwise, we will not be liable for any defect which may arise later in your equipment.
Even when the products are used within the guaranteed values, take into the consideration of incidence of break down and failure mode, possible to occur to semiconductor products. Measures on the systems such as redundant design, arresting the spread of fire or preventing glitch are recommended in order to prevent physical injury, fire, social damages, for example, by using the products.
- (6) Comply with the instructions for use in order to prevent breakdown and characteristics change due to external factors (ESD, EOS, thermal stress and mechanical stress) at the time of handling, mounting or at customer's process. We do not guarantee quality for disassembled products or the product re-mounted after removing from the mounting board.
When using products for which damp-proof packing is required, satisfy the conditions, such as shelf life and the elapsed time since first opening the packages.
- (7) When reselling products described in this book to other companies without our permission and receiving any claim of request from the resale destination, please understand that customers will bear the burden.
- (8) This book may be not reprinted or reproduced whether wholly or partially, without the prior written permission of our company.

No.070920

单击下面可查看定价，库存，交付和生命周期等信息

[>>Panasonic\(松下\)](#)