

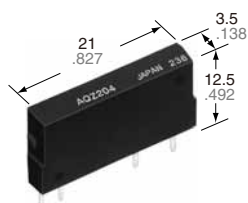

**Slim type with high capacity up to 4A DC load type also available**

**PhotoMOS®  
Power 1 Form A  
(AQZ100, 200)**



(Height includes standoff)

mm inch

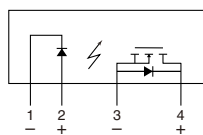

DC type

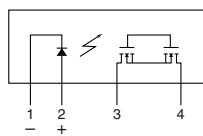

AC/DC type

**RoHS compliant**

### FEATURES

- 1. Slim SIL4-pin package**  
(W) 3.5 × (D) 21.0 × (H) 12.5 mm  
(W) .138 × (D) .827 × (H) .492 inch  
The compact size of the 4-pin SIL package allows high density mounting.
- 2. Extremely low on-resistance**
- 3. Control low-level signal**  
Power PhotoMOS feature extremely low closed-circuit offset voltage to enable control of low-level analog signals without distortion.
- 4. Low-level off state leakage current of max. 10 μA**
- 5. High I/O isolation voltage of 2,500 V**
- 6. Eliminates the need for a counter electromotive protection diode in the drive circuit on the input side**
- 7. Eliminates the need for a power supply to drive the power MOSFET**
- 8. No restriction on mounting direction**
- 9. Low thermoelectromotive force**
- 10. Neither noise nor arc at contact**
- 11. Sockets are also available**  
(PA1a-PS, PA1a-PS-H)
- 12. Can be installed on the RT-3 relay terminal (Power PhotoMOS type)**

### TYPICAL APPLICATIONS

- Traffic signals
- Measuring instruments
- Industrial machines

## TYPES

### 1. DC type

	Output rating*		Package	Part No.	Packing quantity	
	Load voltage	Load current			Inner carton	Outer carton
DC only	60 V	4.0 A	SIL4-pin	AQZ102	25 pcs.	500 pcs.
	100 V	2.6 A		AQZ105		
	200 V	1.3 A		AQZ107		
	400 V	0.7 A		AQZ104		

\* Load voltage and current of DC type: DC

### 2. AC/DC type

	Output rating*		Package	Part No.	Packing quantity	
	Load voltage	Load current			Inner carton	Outer carton
AC/DC dual use	60 V	3.0 A	SIL4-pin	AQZ202	25 pcs.	500 pcs.
	100 V	2.0 A		AQZ205		
	200 V	1.0 A		AQZ207		
	400 V	0.5 A		AQZ204		

\* Load voltage and current of AC/DC type: Peak AC/DC.

## RATING

### 1. DC type

#### 1) Absolute maximum ratings (Ambient temperature: 25°C 77°F)

Item		Symbol	AQZ102	AQZ105	AQZ107	AQZ104	Remarks
Input	LED forward current	$I_F$	50 mA				
	LED reverse voltage	$V_R$	5 V				
	Peak forward current	$I_{FP}$	1 A				f = 100 Hz, Duty factor = 0.1%
	Power dissipation	$P_{in}$	75 mW				
Output	Load voltage (DC)	$V_L$	60 V	100 V	200 V	400 V	
	Continuous load current (DC)	$I_L$	4.0 A	2.6 A	1.3 A	0.7 A	
	Peak load current	$I_{peak}$	9.0 A	6.0 A	3.0 A	1.5 A	100 ms (1 shot), $V_L = DC$
	Power dissipation	$P_{out}$	1.35 W				
Total power dissipation		$P_T$	1.35 W				
I/O isolation voltage		$V_{iso}$	2,500 V AC				
Temperature limits	Operating	$T_{opr}$	-40°C to +85°C -40°F to +185°F				Non-condensing at low temperatures
	Storage	$T_{stg}$	-40°C to +100°C -40°F to +212°F				

#### 2) Electrical characteristics (Ambient temperature: 25°C 77°F)

Item			Symbol	AQZ102	AQZ105	AQZ107	AQZ104	Condition
Input	LED operate current	Typical	$I_{Fon}$	1.0 mA				$I_L = 100 mA$ $V_L = 10 V$
		Maximum		3.0 mA				
	LED turn off current	Minimum	$I_{Foff}$	0.4 mA				$I_L = 100 mA$ $V_L = 10 V$
		Typical		0.9 mA				
LED dropout voltage	Typical	$V_F$	1.25 V (1.16 V at $I_F = 10 mA$ )				$I_F = 50 mA$	
	Maximum		1.5 V					
Output	On resistance	Typical	$R_{on}$	0.05 Ω	0.081 Ω	0.34 Ω	1.06 Ω	$I_F = 10 mA$ $I_L = Max.$ Within 1 s on time
		Maximum		0.09 Ω	0.17 Ω	0.55 Ω	1.6 Ω	
	Off state leakage current	Maximum	$I_{Leak}$	10 μA				$I_F = 0 mA$ $V_L = Max.$
Transfer characteristics	Turn on time*	Typical	$T_{on}$	1.66 ms	1.89 ms	0.83 ms	1.01 ms	$I_F = 10 mA$ $I_L = 100 mA$ $V_L = 10 V$
		Maximum		5.0 ms				
		Typical		3.79 ms	4.50 ms	1.75 ms	2.34 ms	$I_F = 5 mA$ $I_L = 100 mA$ $V_L = 10 V$
		Maximum		10.0 ms				
	Turn off time*	Typical	$T_{off}$	0.15 ms	0.19 ms	0.08 ms	0.08 ms	$I_F = 5 mA$ or 10 mA $I_L = 100 mA$ $V_L = 10 V$
		Maximum		3.0 ms				
	I/O capacitance	Typical	$C_{iso}$	0.8 pF				f = 1 MHz $V_B = 0 V$
		Maximum		1.5 pF				
Initial I/O isolation resistance	Minimum	$R_{iso}$	1,000 MΩ				500 V DC	
Maximum operating speed	Maximum	—	0.5 times/s				$I_F = 10 mA$ Duty factor = 50% $I_L \times V_L = 200 (VA)$	
Vibration resistance	Minimum	—	10 to 55 Hz at double amplitude of 3 mm				2 hours for 3 axes	
Shock resistance	Minimum	—	4,900 m/s <sup>2</sup> {500 G} 1 ms				3 times for 3 axes	

**2. AC/DC type**

**1) Absolute maximum ratings (Ambient temperature: 25°C 77°F)**

Item		Symbol	AQZ202	AQZ205	AQZ207	AQZ204	Remarks
Input	LED forward current	I <sub>F</sub>	50 mA				
	LED reverse voltage	V <sub>R</sub>	5 V				
	Peak forward current	I <sub>FP</sub>	1 A				f = 100 Hz, Duty factor = 0.1%
	Power dissipation	P <sub>in</sub>	75 mW				
Output	Load voltage (Peak AC)	V <sub>L</sub>	60 V	100 V	200 V	400 V	
	Continuous load current	I <sub>L</sub>	3.0 A	2.0 A	1.0 A	0.5 A	Peak AC, DC
	Peak load current	I <sub>peak</sub>	9.0 A	6.0 A	3.0 A	1.5 A	100 ms (1 shot), V <sub>L</sub> = DC
	Power dissipation	P <sub>out</sub>	1.6 W				
Total power dissipation		P <sub>T</sub>	1.6 W				
I/O isolation voltage		V <sub>iso</sub>	2,500 V AC				
Temperature limits	Operating	T <sub>opr</sub>	-40°C to +85°C -40°F to +185°F				Non-condensing at low temperatures
	Storage	T <sub>stg</sub>	-40°C to +100°C -40°F to +212°F				

**2) Electrical characteristics (Ambient temperature: 25°C 77°F)**

Item			Symbol	AQZ202	AQZ205	AQZ207	AQZ204	Condition
Input	LED operate current	Typical	I <sub>Fon</sub>	1.0 mA				I <sub>L</sub> = 100 mA V <sub>L</sub> = 10 V
		Maximum		3.0 mA				
	LED turn off current	Minimum	I <sub>Foff</sub>	0.4 mA				I <sub>L</sub> = 100 mA V <sub>L</sub> = 10 V
		Typical		0.9 mA				
LED dropout voltage	Typical	V <sub>F</sub>	1.25 V (1.16 V at I <sub>F</sub> = 10 mA)				I <sub>F</sub> = 50 mA	
	Maximum		1.5 V					
Output	On resistance	Typical	R <sub>on</sub>	0.11 Ω	0.23 Ω	0.7 Ω	2.1 Ω	I <sub>F</sub> = 10 mA I <sub>L</sub> = Max. Within 1 s on time
		Maximum		0.18 Ω	0.34 Ω	1.1 Ω	3.2 Ω	
	Off state leakage current	Maximum	I <sub>Leak</sub>	10 μA				I <sub>F</sub> = 0 mA V <sub>L</sub> = Max.
Transfer characteristics	Turn on time*	Typical	T <sub>on</sub>	2.46 ms	2.40 ms	1.12 ms	1.65 ms	I <sub>F</sub> = 10 mA I <sub>L</sub> = 100 mA V <sub>L</sub> = 10 V
		Maximum		5.0 ms				
		Typical		5.64 ms	5.65 ms	2.57 ms	3.88 ms	
		Maximum		10.0 ms				
	Turn off time*	Typical	T <sub>off</sub>	0.22 ms	0.21 ms	0.10 ms	0.08 ms	I <sub>F</sub> = 5 mA or 10 mA I <sub>L</sub> = 100 mA V <sub>L</sub> = 10 V
		Maximum		3.0 ms				
	I/O capacitance	Typical	C <sub>iso</sub>	0.8 pF				f = 1 MHz V <sub>B</sub> = 0 V
		Maximum		1.5 pF				
Initial I/O isolation resistance	Minimum	R <sub>iso</sub>	1,000 MΩ				500 V DC	
Maximum operating speed	Maximum	—	0.5 cps				I <sub>F</sub> = 10 mA Duty factor = 50% I <sub>L</sub> = Max., V <sub>L</sub> = Max.	
Vibration resistance	Minimum	—	10 to 55 Hz at double amplitude of 3 mm				2 hours for 3 axes	
Shock resistance	Minimum	—	4,900 m/s <sup>2</sup> {500 G} 1 ms				3 times for 3 axes	

\*Turn on/off time

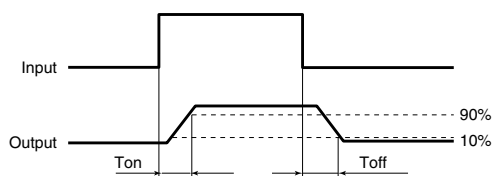

**RECOMMENDED OPERATING CONDITIONS**

Please obey the following conditions to ensure proper device operation and resetting.

Item	Symbol	Recommended value	Unit
Input LED current	I <sub>F</sub>	5 to 10	mA

■ These products are not designed for automotive use.

If you are considering to use these products for automotive applications, please contact your local Panasonic Corporation technical representative.

REFERENCE DATA

1.-(1) Load current vs. ambient temperature characteristics (DC type)

Allowable ambient temperature: -40°C to +85°C  
-40°F to +185°F

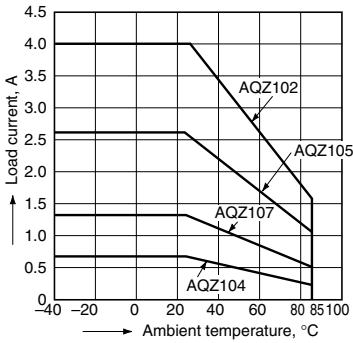

1.-(2) Load current vs. ambient temperature characteristics (AC/DC type)

Allowable ambient temperature: -40°C to +85°C  
-40°F to +185°F

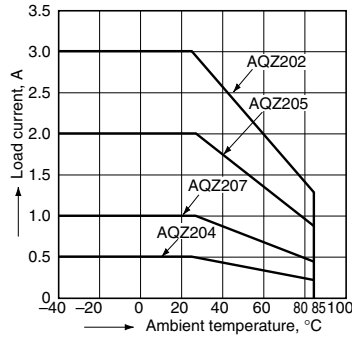

2. Load current vs. ambient temperature characteristics in adjacent mounting

$I_L$  : Load current;  
 $I_L$  (max.): Maximum continuous load current

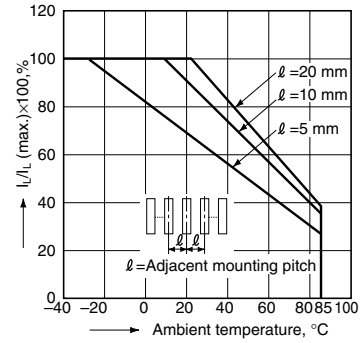

3.-(1) On resistance vs. ambient temperature characteristics (DC type)

LED current: 10 mA;  
Continuous load current: 1.6 A (DC) (AQZ102),  
1.04 A (DC) (AQZ105)

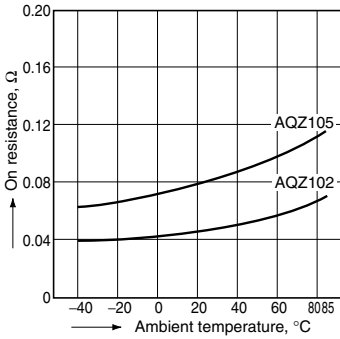

3.-(2) On resistance vs. ambient temperature characteristics (DC type)

LED current: 10 mA;  
Continuous load current: 0.52 A (DC) (AQZ107),  
0.28 A (DC) (AQZ104)

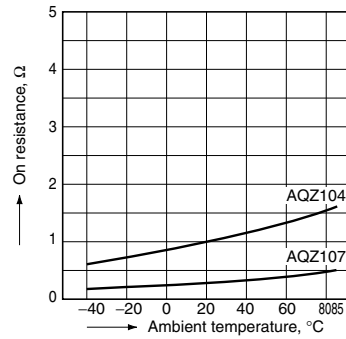

3.-(3) On resistance vs. ambient temperature characteristics (AC/DC type)

LED current: 10 mA;  
Continuous load current: 1.2 A (DC) (AQZ202),  
0.8 A (DC) (AQZ205)

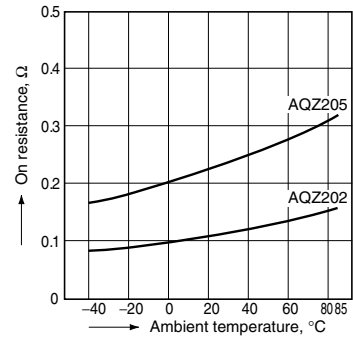

3.-(4) On resistance vs. ambient temperature characteristics (AC/DC type)

LED current: 10 mA;  
Continuous load current: 0.4 A (DC) (AQZ207),  
0.2 A (DC) (AQZ204)

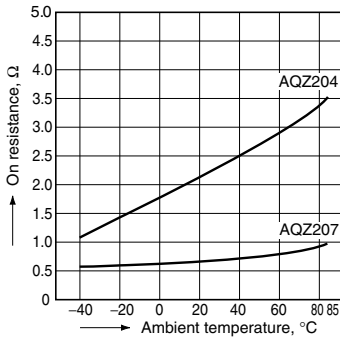

4.-(1) Turn on time vs. ambient temperature characteristics (DC type)

LED current: 10 mA;  
Load voltage: 10 V (DC);  
Continuous load current: 100 mA (DC)

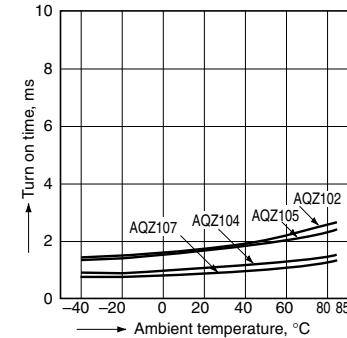

4.-(2) Turn on time vs. ambient temperature characteristics (AC/DC type)

LED current: 10 mA;  
Load voltage: 10 V (DC);  
Continuous load current: 100 mA (DC)

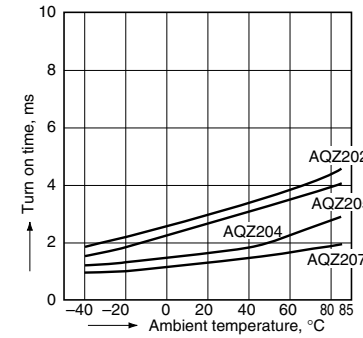

5.-(1) Turn off time vs. ambient temperature characteristics (DC type)

LED current: 10 mA;  
Load voltage: 10 V (DC);  
Continuous load current: 100 mA (DC)

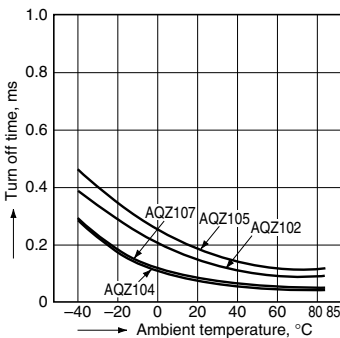

5.-(2) Turn off time vs. ambient temperature characteristics (AC/DC type)

LED current: 10 mA;  
Load voltage: 10 V (DC);  
Continuous load current: 100 mA (DC)

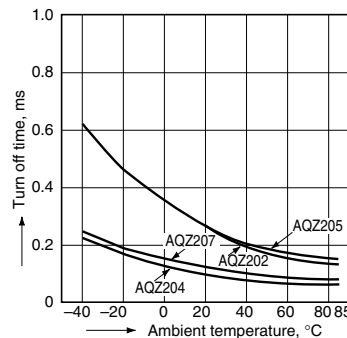

6.-(1) LED operate vs. ambient temperature characteristics (DC type)

Load voltage: 10 V (DC);  
Continuous load current: 100 mA (DC)

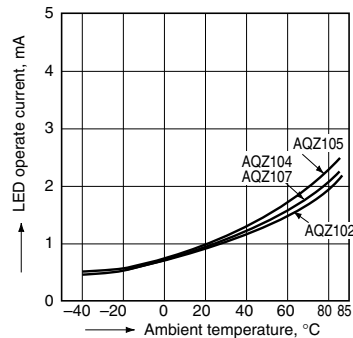

6.-(2) LED operate vs. ambient temperature characteristics (AC/DC type)

Load voltage: 10 V (DC);  
Continuous load current: 100 mA (DC)

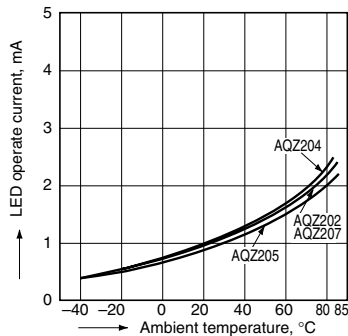

7.-(1) LED turn off current vs. ambient temperature characteristics (DC type)

Load voltage: 10 V (DC);  
Continuous load current: 100 mA (DC)

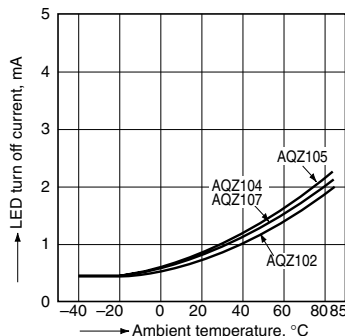

7.-(2) LED turn off current vs. ambient temperature characteristics (AC/DC type)

Load voltage: 10 V (DC);  
Continuous load current: 100 mA (DC)

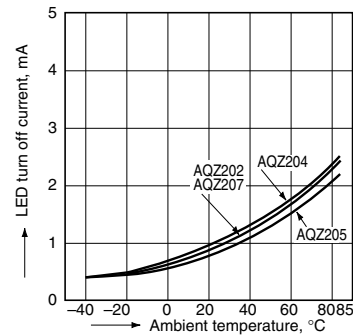

8. LED dropout voltage vs. ambient temperature characteristics

Sample: all types; LED current: 5 to 50 mA

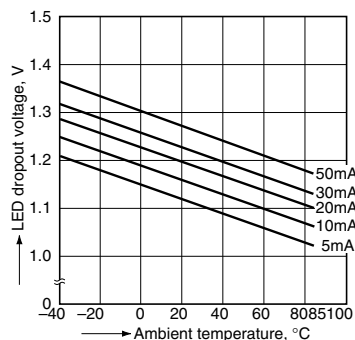

9.-(1) Current vs. voltage characteristics of output at MOS portion (DC type)

Ambient temperature: 25°C 77°F

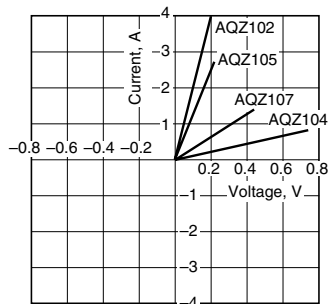

9.-(2) Current vs. voltage characteristics of output at MOS portion (AC/DC type)

Ambient temperature: 25°C 77°F

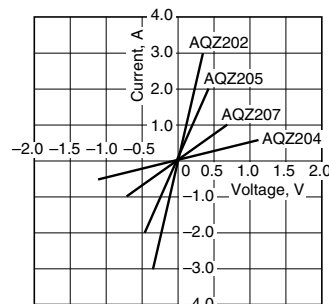

10.-(1) Off state leakage current vs. load voltage characteristics

Ambient temperature: 25°C 77°F

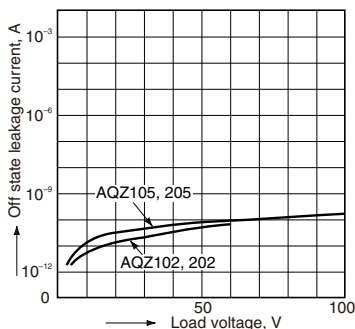

10.-(2) Off state leakage current vs. load voltage characteristics

Ambient temperature: 25°C 77°F

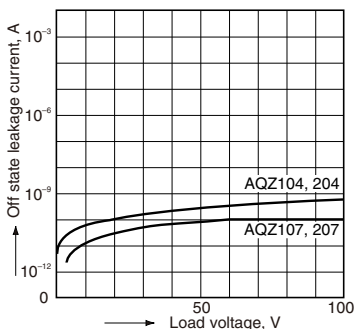

11.-(1) Turn on time vs. LED forward current characteristics (DC type)

Load voltage: 10 V (DC);  
Continuous load current: 100 mA (DC);  
Ambient temperature: 25°C 77°F

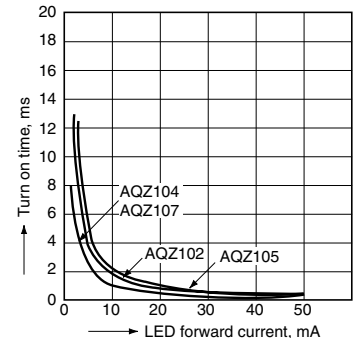

11.-(2) Turn on time vs. LED forward current characteristics (AC/DC type)

Load voltage: 10 V (DC);  
Continuous load current: 100 mA (DC);  
Ambient temperature: 25°C 77°F

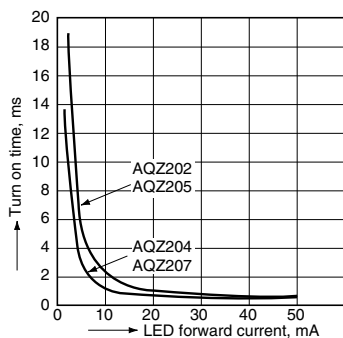

12.-(1) Turn off time vs. LED forward current characteristics (DC type)

Measured portion: between terminals 4 and 6;  
Load voltage: 10 V (DC);  
Continuous load current: 100 mA (DC);  
Ambient temperature: 25°C 77°F

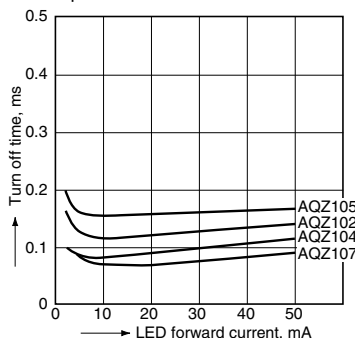

12.-(2) Turn off time vs. LED forward current characteristics (AC/DC type)

Load voltage: 10 V (DC);  
Continuous load current: 100 mA (DC);  
Ambient temperature: 25°C 77°F

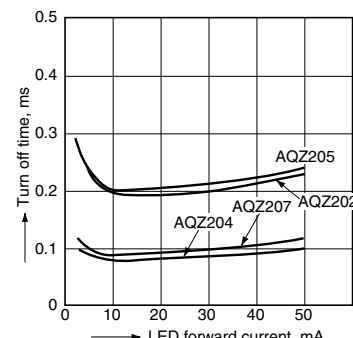

# Power 1 Form A (AQZ100, 200)

13.-(1) Turn on time vs. load voltage characteristics (DC type)

LED current: 10 mA;  
Continuous load current: 100 mA;  
Ambient temperature: 25°C 77°F

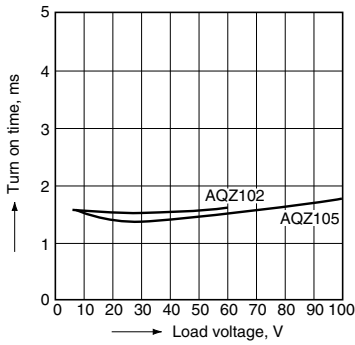

13.-(2) Turn on time vs. load voltage characteristics (DC type)

LED current: 10 mA;  
Continuous load current: 100 mA;  
Ambient temperature: 25°C 77°F

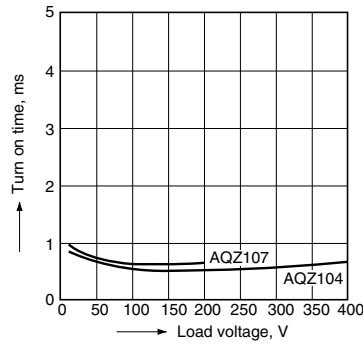

13.-(3) Turn on time vs. load voltage characteristics (AC/DC type)

LED current: 10 mA;  
Continuous load current: 100 mA;  
Ambient temperature: 25°C 77°F

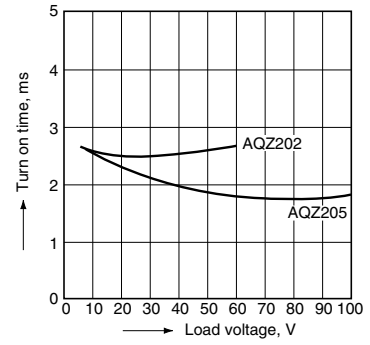

13.-(4) Turn on time vs. load voltage characteristics (AC/DC type)

LED current: 10 mA;  
Continuous load current: 100 mA;  
Ambient temperature: 25°C 77°F

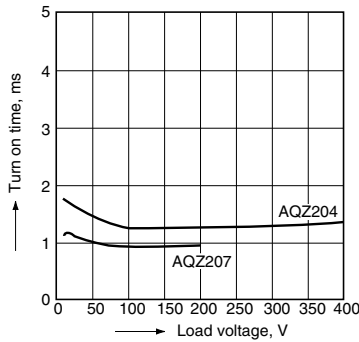

14.-(1) Turn on time vs. load current characteristics (DC type)

LED current: 10 mA;  
Load voltage: 10 V (DC);  
Ambient temperature: 25°C 77°F

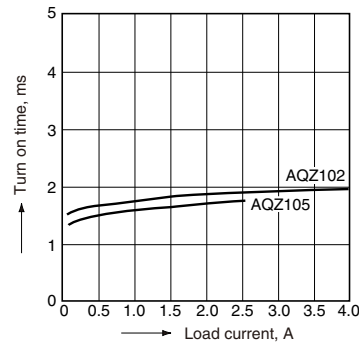

14.-(2) Turn on time vs. load current characteristics (DC type)

LED current: 10 mA;  
Load voltage: 10 V (DC);  
Ambient temperature: 25°C 77°F

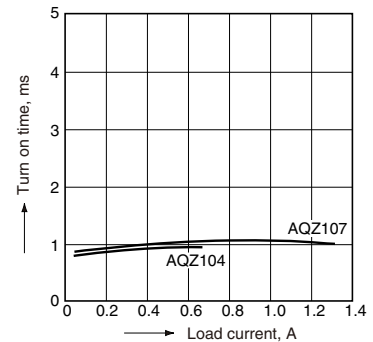

14.-(3) Turn on time vs. load current characteristics (AC/DC type)

LED current: 10 mA;  
Load voltage: 10 V (DC);  
Ambient temperature: 25°C 77°F

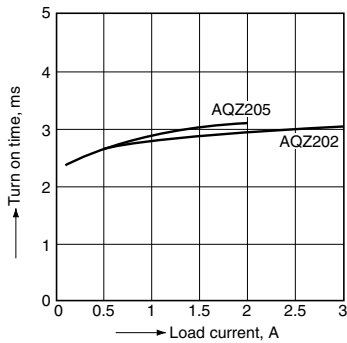

14.-(4) Turn on time vs. load current characteristics (AC/DC type)

LED current: 10 mA;  
Load voltage: 10 V (DC);  
Ambient temperature: 25°C 77°F

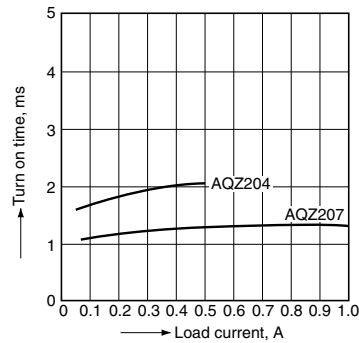

15.-(1) Turn off time vs. load voltage characteristics (DC type)

LED current: 10 mA;  
Continuous load current: 100 mA;  
Ambient temperature: 25°C 77°F

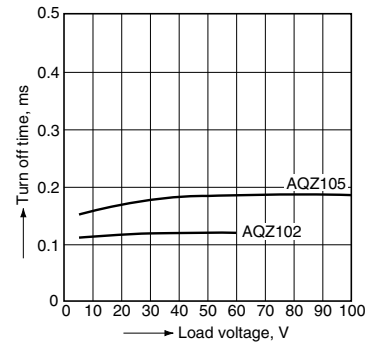

15.-(2) Turn off time vs. load voltage characteristics (DC type)

LED current: 10 mA;  
Continuous load current: 100 mA;  
Ambient temperature: 25°C 77°F

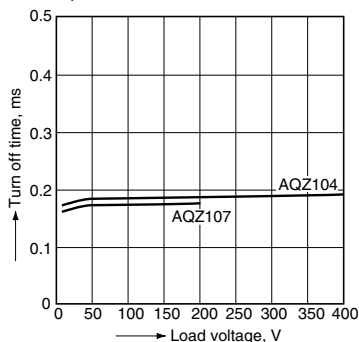

15.-(3) Turn off time vs. load voltage characteristics (AC/DC type)

LED current: 10 mA;  
Continuous load current: 100 mA;  
Ambient temperature: 25°C 77°F

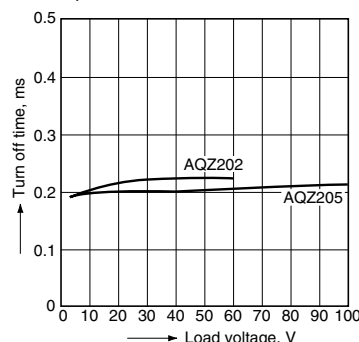

15.-(4) Turn off time vs. load voltage characteristics (AC/DC type)

LED current: 10 mA;  
Continuous load current: 100 mA;  
Ambient temperature: 25°C 77°F

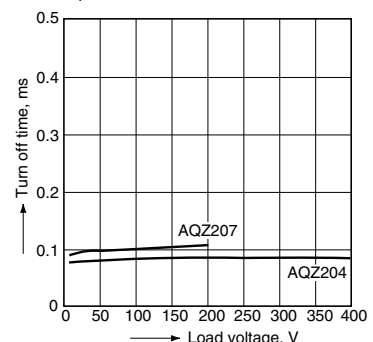

16.-(1) Turn off time vs. load current characteristics (DC type)

LED current: 10 mA;  
Load voltage: 10 V (DC);  
Ambient temperature: 25°C 77°F

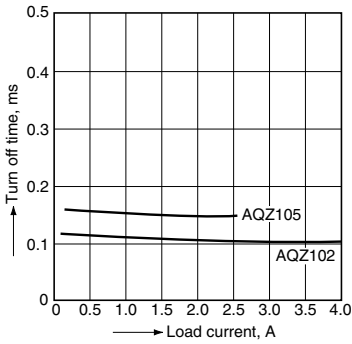

16.-(2) Turn off time vs. load current characteristics (DC type)

LED current: 10 mA;  
Load voltage: 10 V (DC);  
Ambient temperature: 25°C 77°F

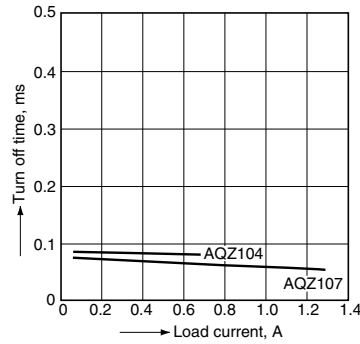

16.-(3) Turn off time vs. load current characteristics (AC/DC type)

LED current: 10 mA;  
Load voltage: 10 V (DC);  
Ambient temperature: 25°C 77°F

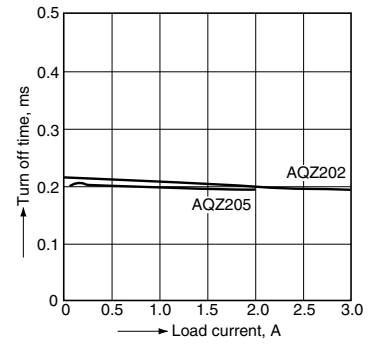

16.-(4) Turn off time vs. load current characteristics (AC/DC type)

LED current: 10 mA;  
Load voltage: 10 V (DC);  
Ambient temperature: 25°C 77°F

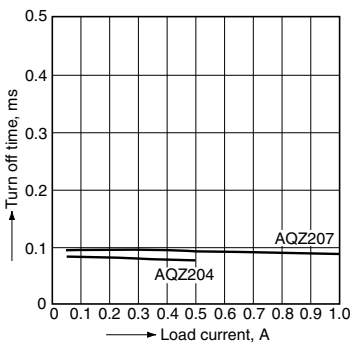

17. Maximum operating frequency vs. load voltage/current characteristics

Sample: All types;  
LED current: 10 mA;  
Ambient temperature: 25°C 77°F

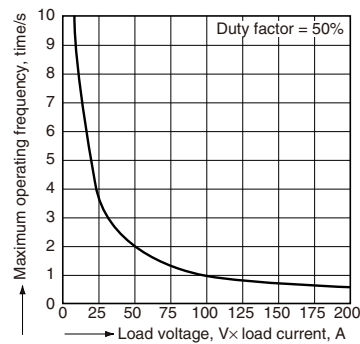

18.-(1) Output capacitance vs. applied voltage characteristics (DC type)

Frequency: 1 MHz;  
Ambient temperature: 25°C 77°F

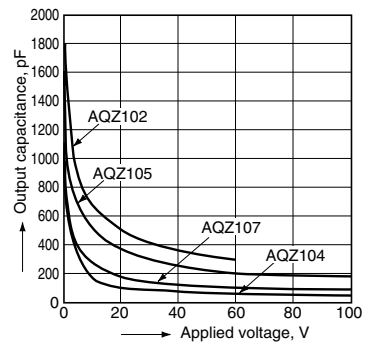

18.-(2) Output capacitance vs. applied voltage characteristics (AC/DC type)

Frequency: 1 MHz;  
Ambient temperature: 25°C 77°F

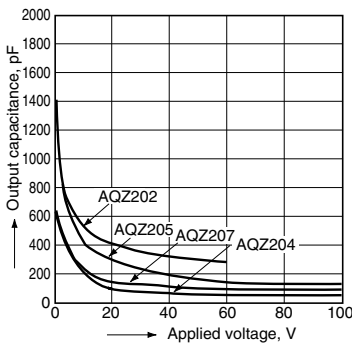

ACCESSORY (mm inch)

Socket

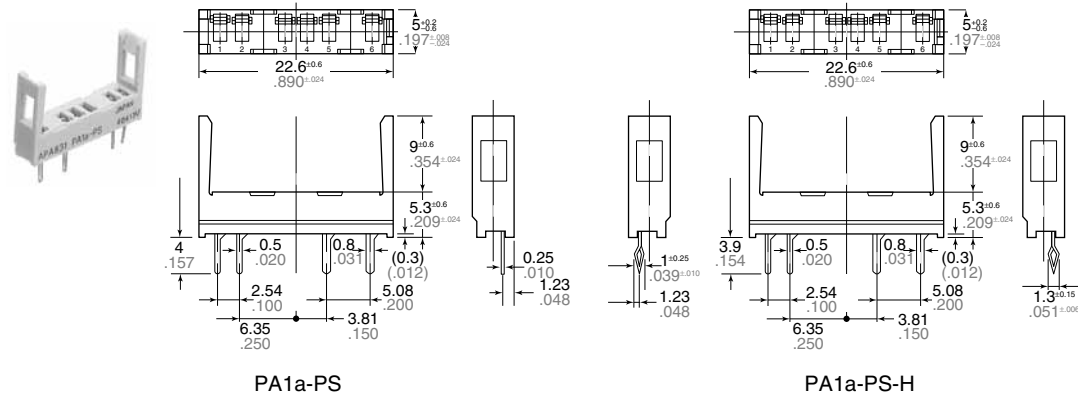

PC board pattern (BOTTOM VIEW) Standard type

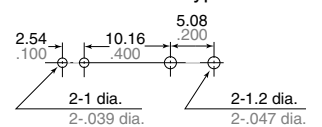

Self clinching type

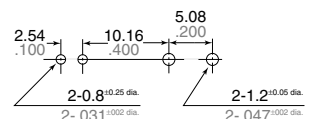

Tolerance: ±0.1 ±0.04

单击下面可查看定价，库存，交付和生命周期等信息

[>>Panasonic\(松下\)](#)