



DATA SHEET

PS100R~PS1010R

FAST RECOVERY PLASTIC RECTIFIER

VOLTAGE 50 to 1000 Volts **CURRENT** 1.0 Amperes

DO-41

Unit: inch(mm)

FEATURES

- High current capability.
- Plastic package has Underwriters Laboratory Flammability Classification 94V-O utilizing Flame Retardant Epoxy Molding Compound.
- Low leakage.
- Exceeds environmental standards of MIL-S-19500/228
- Fast switching for high efficiency.
- Pb free product are available : 99% Sn above can meet Rohs environment substance directive request

MECHANICAL DATA

Case: Molded plastic, DO-41
 Terminals: Axial leads, solderable to MIL-STD-202G, Method 208
 Polarity: Color Band denotes cathode end
 Mounting Position: Any
 Weight: 0.012 ounce, 0.336 gram

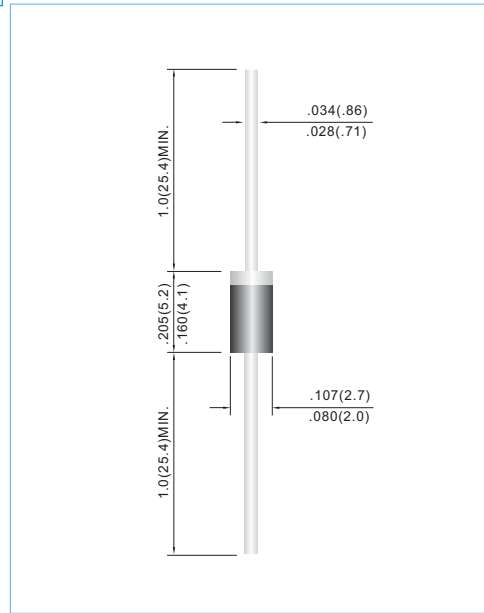

MAXIMUM RATINGS AND ELECTRICAL CHARACTERISTICS

Ratings at 25°C ambient temperature unless otherwise specified. Resistive or inductive load, 60Hz.

PARAMETER	SYMBOL	PS100R	PS101R	PS102R	PS104R	PS106R	PS108R	PS1010R	UNITS
Maximum Recurrent Peak Reverse Voltage	V _{RRM}	50	100	200	400	600	800	1000	V
Maximum RMS Voltage	V _{RMS}	35	70	140	280	420	560	700	V
Maximum DC Blocking Voltage	V _{DC}	50	100	200	400	600	800	1000	V
Maximum Average Forward Current .375"(9.5mm) lead length at TA=55°C	I _{AV}	1.0							A
Peak Forward Surge Current : 8.3ms single half sine-wave superimposed on rated load(JEDEC method)	I _{FSM}	30							A
Maximum Forward Voltage at 1.0A	V _F	1.3							V
Maximum DC Reverse Current TA=25°C at Rated DC Blocking Voltage TA=100°C	I _R	5.0 500							uA
Maximum Reverse Recovery Time (Note 1)	T _{RR}	150				250	500		ns
Typical Junction capacitance (Note 2)	C _J	12							pF
Typical Thermal Resistance (Note 3)	R _{θJA}	41							°C / W
Operating Junction and Storage Temperature Range	T _J , T _{STG}	-55 TO +150							°C

NOTES: 1. Reverse Recovery Test Conditions: I_F=.5A, I_R=1A, I_{rr}=.25A
 2. Measured at 1 MHz and applied reverse voltage of 4.0 VDC
 3. Thermal resistance from junction to ambient at 0.375"(9.5mm) lead length with both leads equally heatsink.



RATING AND CHARACTERISTIC CURVES

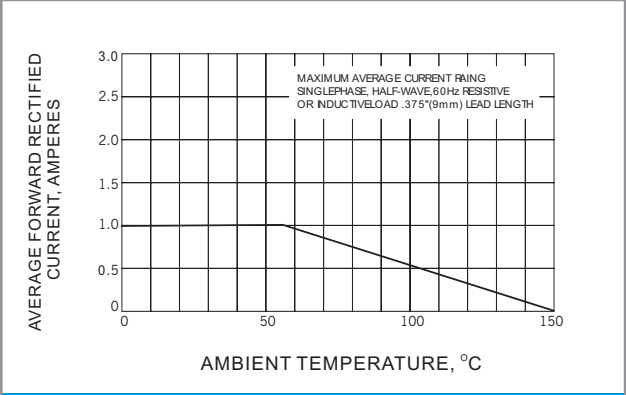

Fig. 1 FORWARD CURRENT DERATING CURVE

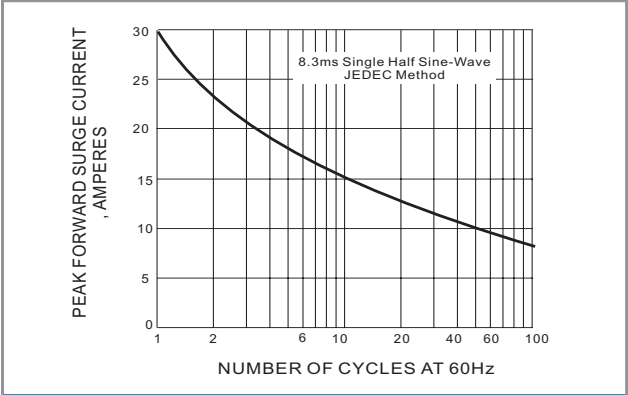

Fig. 2-MAXIMUM NON-REPETITIVE PEAK FORWARD SURGE CURRENT

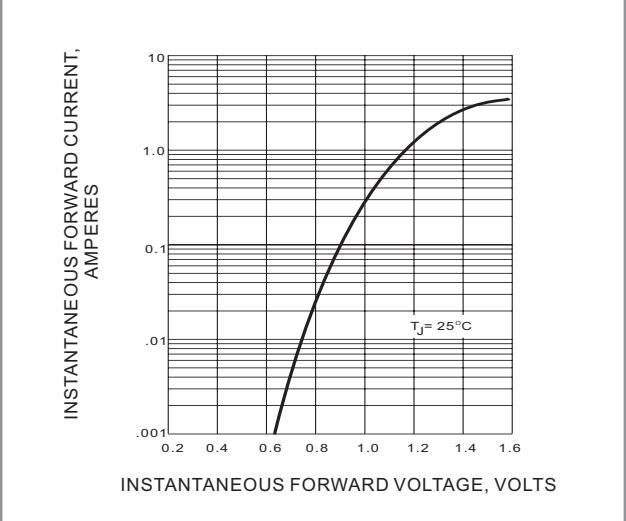

Fig. 3-TYPICAL INSTANTANEOUS FORWARD CHARACTERISTICS

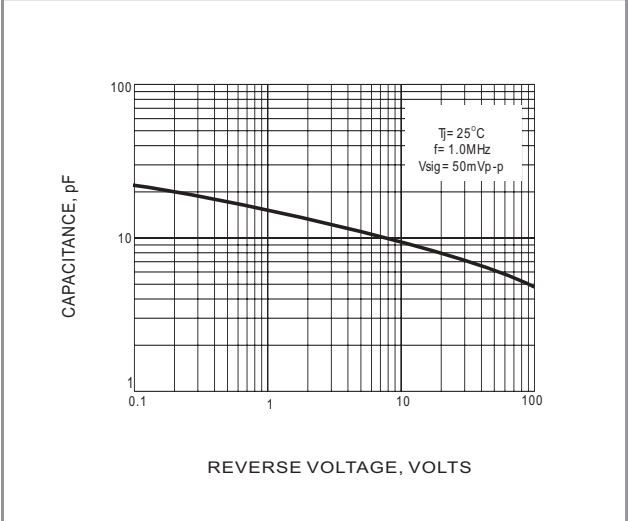

Fig. 4 TYPICAL JUNCTION CAPACITANCE

单击下面可查看定价，库存，交付和生命周期等信息

[>>Panjit\(强茂\)](#)