

Features and Benefits

- Four grades of magnetic materials
- Cost effective design
- High resistance to demagnetization
- Operation from -40°C to 125°C
- Tough environmental endurance
- Very resistant to chipping

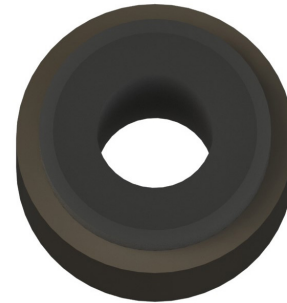

Molded Target Magnet

Physical Properties of Magnetic Material

Table 1.1

Characteristic	Value	Units
Tensile Strength	6500	PSI
Flexural Strength	9750	PSI
Flexural Modulus	1.3 X 10 ⁶	PSI
Continuous Service Temperature	100	°C

Magnetic Properties

Table 1.2

Characteristic	Magnalox 300	Neobond 12M	Neobond 30M	Neobond 32P	Units
Remanence (B _r)	1370	2500	4000	4300	Gauss
Coercive Force (H _c)	1180	2400	3250	2500	MGOe
Energy Product (BH _{MAX})	0.40	1.3	3.1	3.2	Oersted
Intrinsic Coercive Force (H _{ci})	2300	7500	7000	6900	Oersted
Reversible Temperature Coefficient	-0.2	-0.35	-0.4	-0.4	/°C
Specific Gravity	3.5	4.0	4.7	4.45	---

Pole Counts

Alternating north and south magnetic poles are symmetrically located on the outer diameter for radial sensing.

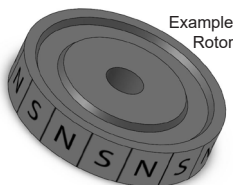

Note: (N)orth/(S)outh markings are for illustration and do not appear on the actual product.

Available Pole Counts	8, 12, 16, 20
-----------------------	---------------

Target Rotor Physical Outline - Engineered Polymer Hub (Mounting Style H)

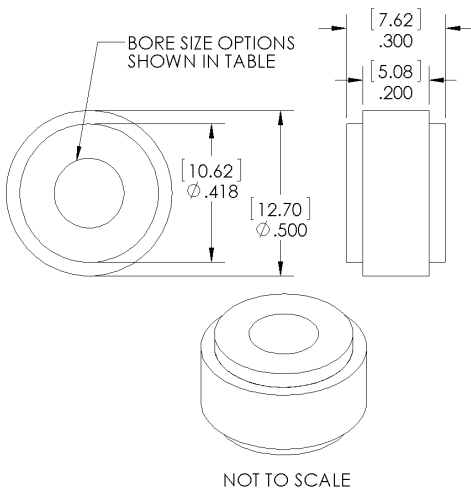

Table 2.1

Bore Size (.inch)	Motor Shaft OD Size (nominal)	NEMA Guide Shaft Tolerance	Magnet Bore MIN. (inch)	Magnet Bore MAX. (inch)
079	2 mm (.0787")	+0.0000"/-0.0005"	.0727	.0757
118	3 mm (.1181")		.1121	.1151
125	1/8 in (.1250")		.1190	.1220
156	5/32 in (.1563")		.1503	.1533
157	4 mm (.1575")		.1515	.1545
188	3/16 in (.1875")		.1815	.1845
197	5 mm (.1969")		.1909	.1939
236	6 mm (.2364")		.2304	.2334
250	1/4 in (.2500")		.2440	.2470
276	7 mm (.2758")		.2698	.2728
313	5/16 in (.3125")		.3065	.3095
315	8 mm (.3150")		.3090	.3120
375	3/8 in (.3750")		.3690	.3720

Other bore sizes available upon request.
Contact sales@phoenixamerica.com.

Target Rotor Mounting Guidelines - Engineered Polymer Hub (Mounting Style H) For Press Fit Application

- Proper alignment of the target rotor is critical for optimal performance.
- A machined step on the motor shaft provides a quick and repeatable method for positioning the target rotor. Spacers or other fixturing should be used if no mechanical locating features are on the shaft.
- A chamfered lead in on the shaft will aid in aligning the rotor.
- Prior to insertion, the motor shaft should be clean and free of any oils, lubricants, or solvents.
- Proper fixtures and support must be used to ensure the magnet is pressed on straight and aligned with the motor shaft.
- Opposite end of motor shaft should be supported to avoid undue stress on motor bearings during the pressing operation.
- In applications with high torque or environmental extremes, a retaining compound can be used to enhance the strength of the press fit.

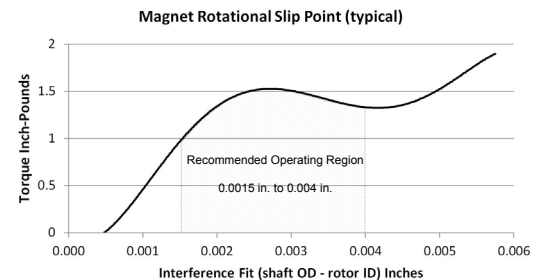
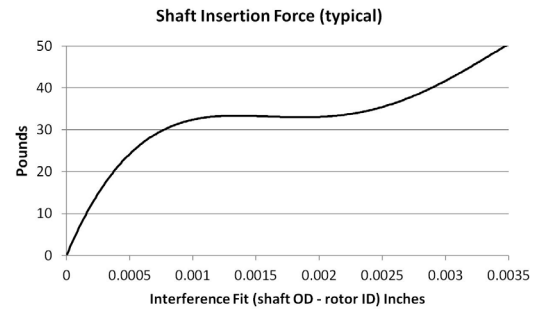
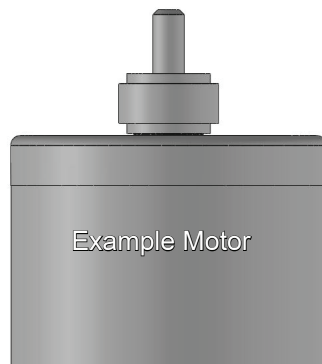

Part Number Description

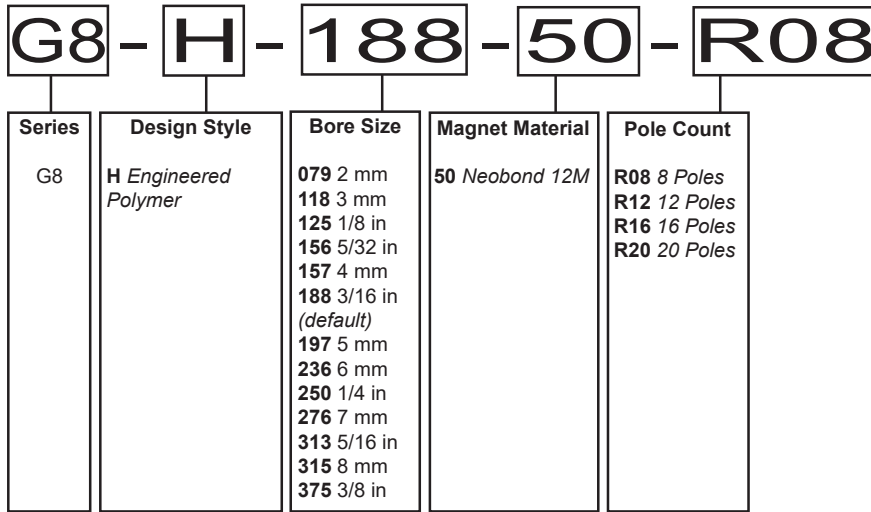

Example: G8-H-188-50-R08

单击下面可查看定价，库存，交付和生命周期等信息

[>>Phoenix Contact\(菲尼克斯\)](#)