

## Foot element - UM 25/45-FEO 200 - 2959434

Please be informed that the data shown in this PDF Document is generated from our Online Catalog. Please find the complete data in the user's documentation. Our General Terms of Use for Downloads are valid (<http://phoenixcontact.com/download>)



Foot element, is inserted in the profile housing, limit stop with screw. Mounted at right angles to the NS 35/7.5 DIN rail

### Your advantages

- Easy installation
- Flexible size and shape
- Inexpensive as a result of reducing the number of separate housing parts



### Key Commercial Data

Packing unit	10 pc
Minimum order quantity	10 pc
GTIN	 4 017918 117610
GTIN	4017918117610

### Technical data

#### Product properties

Brief article description	Foot element
Type	UM 25/45-FEO 200
Item no.	2959434
Housing type	Press-drawn section housings
Housing series	UM

#### Dimensions

#### Material specifications

Housing material	Polyamide
Color (RAL)	green
Flammability rating according to UL 94	V0
Surface characteristics	untreated

# Foot element - UM 25/45-FEO 200 - 2959434

## Technical data

### Packaging specifications

Pieces per package	10
Denomination packing units	Pcs.

### Environmental Product Compliance

China RoHS	Environmentally friendly use period: unlimited = EFUP-e
	No hazardous substances above threshold values

## Drawings

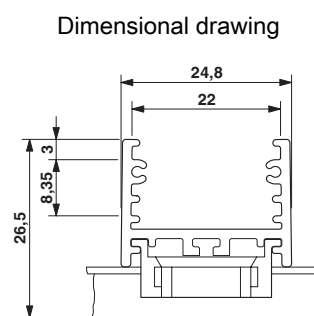
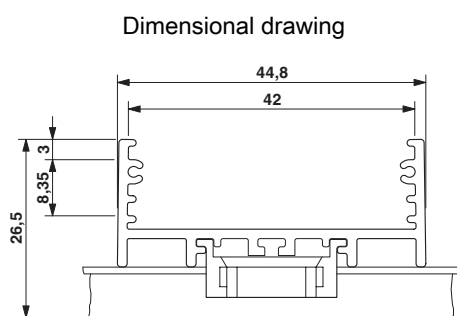

## Classifications

### eCl@ss

eCl@ss 11.0	27182701
eCl@ss 4.0	27180400
eCl@ss 4.1	27180400
eCl@ss 5.0	27180500
eCl@ss 5.1	27180500
eCl@ss 6.0	27180800
eCl@ss 7.0	27182701

### ETIM

ETIM 2.0	EC001031
ETIM 3.0	EC001031
ETIM 4.0	EC001031
ETIM 6.0	EC002779
ETIM 7.0	EC002779

### UNSPSC

UNSPSC 6.01	31261501
UNSPSC 7.0901	31261501
UNSPSC 11	31261501
UNSPSC 12.01	31261501
UNSPSC 13.2	31261501

# Foot element - UM 25/45-FEO 200 - 2959434

## Classifications

### UNSPSC

UNSPSC 18.0	31261501
UNSPSC 19.0	31261501
UNSPSC 20.0	31261501
UNSPSC 21.0	31261500

## Approvals

### Approvals

---

Approvals

EAC / UL Recognized

---

Ex Approvals

---

### Approval details

EAC		B.01687
-----	---	---------

UL Recognized		<a href="http://database.ul.com/cgi-bin/XYV/template/LISEXT/1FRAME/index.htm">http://database.ul.com/cgi-bin/XYV/template/LISEXT/1FRAME/index.htm</a>	FILE E 240868
---------------	---	---	---------------

---

Phoenix Contact 2022 © - all rights reserved  
<http://www.phoenixcontact.com>

PHOENIX CONTACT GmbH & Co. KG  
Flachsmarktstr. 8  
32825 Blomberg  
Germany  
Tel. +49 5235 300  
Fax +49 5235 3 41200  
<http://www.phoenixcontact.com>

单击下面可查看定价，库存，交付和生命周期等信息

[>>Phoenix Contact \(菲尼克斯\)](#)