

Industrial M12 Speedcon Mini-B USB

PCB-mounted USB Receptacle



COMBICON

Data Sheet
2792_en_D

© PHOENIX CONTACT 2011-01-18

1 Description

For harsh industrial applications in small spaces, Phoenix Contact offers the M12 Mini-B USB receptacle for PCB installation. This compact, M12 Mini-B USB receptacle satisfies the challenging needs of miniature industrial devices and instruments requiring a small footprint. The M12 Speedcon quick connector provides a high-quality, secure connection for high-speed data acquisition.

The PCB receptacle is available in a straight orientation. The unique internal ground spring on the PCB receptacle improves shielding effectiveness by connecting the M12 Mini-B USB to a metal chassis for continuous ground path.

Optional mini-B to Type A USB cables are manufactured with industrial overmold and an M12 metal coupling nut for additional strain relief and protection from corrosive environments. When it comes to assembly, M12 Speedcon allows quick installation while ensuring positive locking and high cable retention.

2 Features

- IP67 M12 Speedcon quick disconnect metal housing for water and dust protection
- Metal receptacle shell with ground spring
- Smallest mini-B USB industrial connector
- Direct PCB mount
- USB (Universal Serial Bus) 2.0 interface, up to 480 Mbps transfer rate
- Optional fully shielded, industrial grade, overmolded cable assemblies with M12 Speedcon locking for better strain relief
- 90° or pigtail mounting options available upon request



Make sure you always use the latest documentation.
It can be downloaded at www.phoenixcontact.net/catalog.



This data sheet is valid for all products listed on the following page:

3 Ordering Data

Products

Description	Type	Order No.	Pcs./Pkt.
Mini-B USB PCB receptacle with M12 Speedcon, straight	VS-EC-MSDB SH SCO	1440711	20

Accessories

Description	Type	Order No.	Pcs./Pkt.
Cable, M12 Speedcon, Mini USB plug to USB Type A (IP20), 1 m	VS-FSDB-IP20SDA/981/1,0 SCO	1420168	1
Cable, M12 Speedcon, Mini USB plug to USB Type A (IP20), 2 m	VS-FSDB-IP20SDA/981/2,0 SCO	1420171	1
Cable, M12 Speedcon, Mini USB plug to USB Type A (IP20), 5 m	VS-FSDB-IP20SDA/981/5,0 SCO	1420184	1
Plastic sealing cap, M12 with holding band	PROT-M12 FS-PA-CHAIN	1430873	5

4 Technical Data

Electrical Data

Rated voltage	30 V
Rated current (I_N)	1 A
Transmission speed	480 Mbps

General Data

Flammability	UL94-V0
Contact surface material	Au/Ni
Contact material	Copper alloy
Contact carrier material	Thermoplastic
Nominal PCB thickness	1.6 mm
PCB connection	Wave soldering
Maximum panel thickness	4 mm
Operating temperature	-25...+85°C
Degree of protection	IP67 (when connected)
Mounting type	Rear mounting M12 x 1 with flat nut
Torque to panel	1.5...2.0 Nm

Approval/Conformance

	RoHS compliance
	USB 2.0

5 Dimensions

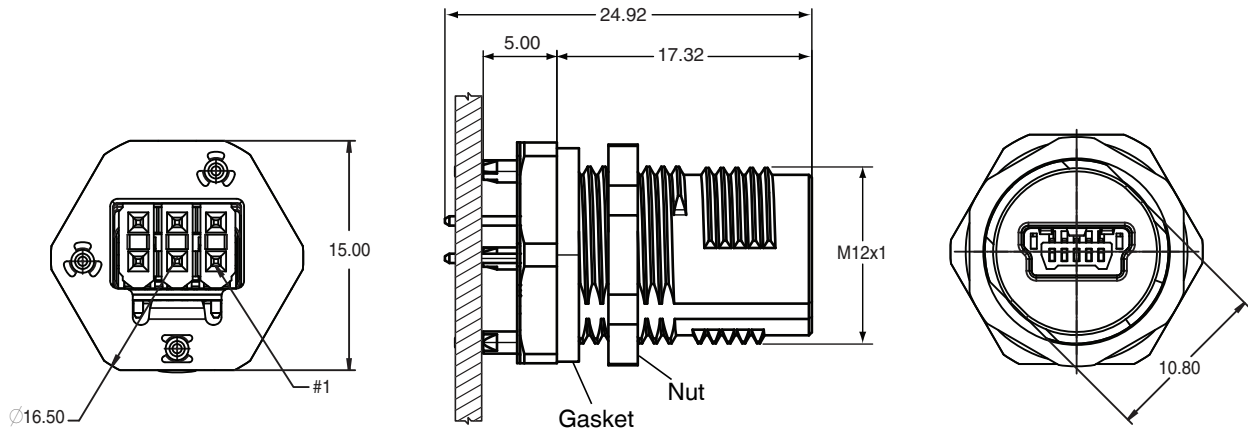

Figure 1 Connector dimensions

Two panel mounting options are available. The panel can be threaded for M12 x 1 or the panel cutout can be cut with flat sides for an anti-twist installation. The connector is then secured with an M12 nut. Tighten to 1.5-2.0 Nm.

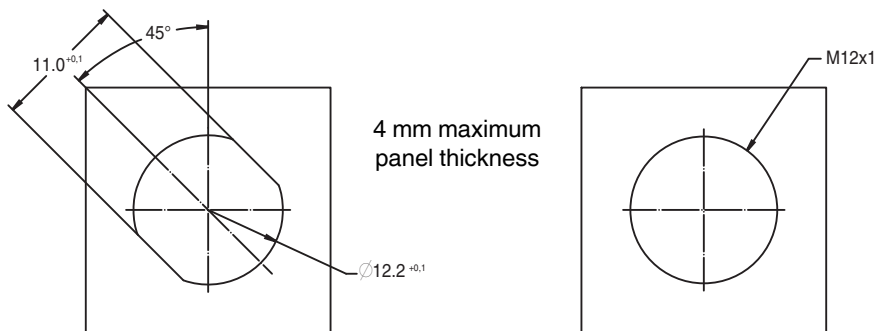

Figure 2 Panel cutout options

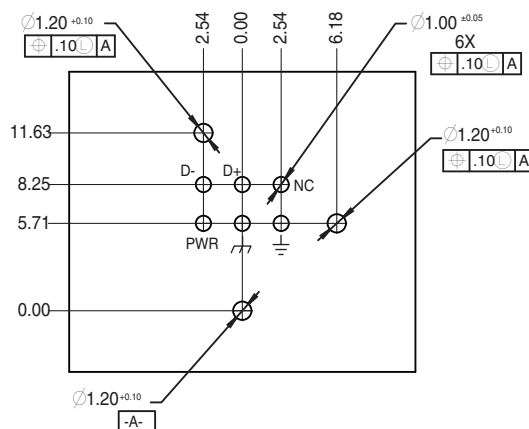

Figure 3 PCB layout (component side)

PCB hole location tolerance is ± 0.10 mm for both X and Y axis.

5.1 Cable Dimensions

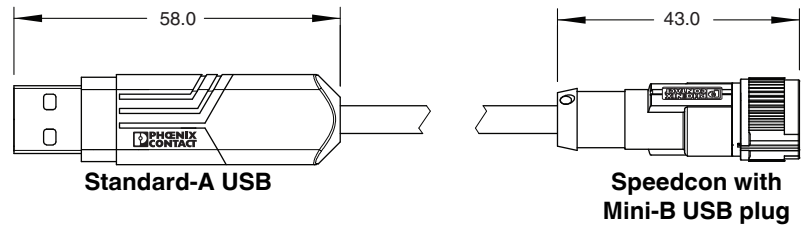

Figure 4 USB cable end dimensions

单击下面可查看定价，库存，交付和生命周期等信息

[>>Phoenix Contact\(菲尼克斯\)](#)