

TMC 7... and TMC 8...

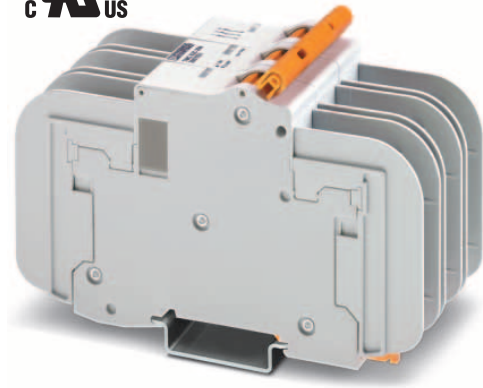

Thermal magnetic UL Listed and UL Recognized miniature circuit breakers



Data sheet
3644_en_C

© PHOENIX CONTACT 2018-11-08

1 Description

TMC 8... miniature circuit breakers (MCB) are UL 489 Listed to provide branch overload and short-circuit protection. An interrupt capacity of 10 kAIC at up to 277/480 V AC and 125 V DC makes the TMC 8... ideal for a wide range of applications that require a UL 489 Listed circuit breaker.

TMC 7... miniature circuit breakers are UL 1077 Recognized and provide supplemental overload and short-circuit protection. Short-circuit current ratings range from 5 kAIC to 7.5 kAIC, depending upon the supply voltage.

The circuit breakers are available in 1-, 2-, and 3-pole configurations with B, C, and D trip curve options, making them ideal for a wide range of applications. They are 17.6 mm wide (per pole) and mount on 35 mm NS35 rail. Available accessories include an auxiliary contact, alarm contact, shunt trips, and busbars.

The TMC 7... is UL Recognized for the U.S. and Canada. The TMC 8... is UL Listed for the U.S. and Canada. Both products lines carry the CE mark.

1.1 Typical applications

TMC 7/8... circuit breakers are suitable for protection of

- cables
- motors
- generators and transformers
- thyristors
- silicon rectifiers
- computers and peripheral equipment
- industrial process control systems
- telecommunications equipment
- power supplies

1.2 Features

- TMC 7... is UL 1077 Recognized
- TMC 8... is UL 489 Listed
- 1-, 2-, and 3-pole configurations
- Current ratings of 1 to 63 A
- Available with B, C, and D trip curves
- Visual status indication
- Trip-free, snap-action mechanism cannot be manually overridden in an overload situation
- Full range of bus bars and accessories



This document is valid for all products listed in the "Ordering data" on page 3.

Table of contents

1	Description.....	1
1.1	Typical applications.....	1
1.2	Features.....	1
2	Ordering data.....	3
3	Technical data	11
3.1	Trip curve	12
3.2	Current rating and voltage drop @ 25°C	12
3.3	Dimensions	13
3.4	Environmental influences	14
4	Circuit breaker installation	14
4.1	Mounting	14
4.2	Removal.....	14
4.3	DC connection diagram	14
5	Accessories	15
6	Ordering data for accessories.....	16
7	Technical data for accessories	17
7.1	Technical data for TMC 7/8 AUX and TMC 7/8 ALARM accessories	17
7.2	Technical data for busbars and termination pins	18
8	Accessory descriptions.....	19
8.1	Auxiliary contact (TMC 7/8 AUX).....	19
8.2	Alarm contact (TMC 7/8 ALARM).....	19
8.3	Shunt trip (TMC 7/8...SHNT).....	20
9	TMC 7/8 AUX / TMC 7/8 ALARM / TMC 7/8...SHNT installation	20
9.1	Busbars and related accessories	21

2 Ordering data

Order key

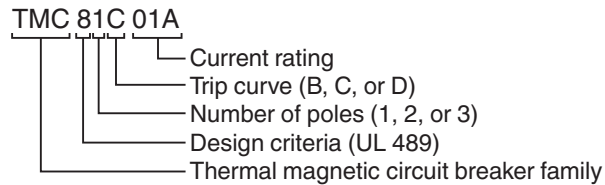

Products

Description	Type	Order No.	Pcs./Pkt.
MCB, up to 60 V DC and 277 V AC, B curve 1-pole 1 A	TMC 81B 01A	2907478	1
MCB, up to 60 V DC and 277 V AC, B curve 1-pole 2 A	TMC 81B 02A	2907479	1
MCB, up to 60 V DC and 277 V AC, B curve 1-pole 3 A	TMC 81B 03A	2907480	1
MCB, up to 60 V DC and 277 V AC, B curve 1-pole 4 A	TMC 81B 04A	2907481	1
MCB, up to 60 V DC and 277 V AC, B curve 1-pole 5 A	TMC 81B 05A	2907482	1
MCB, up to 60 V DC and 277 V AC, B curve 1-pole 6 A	TMC 81B 06A	2907483	1
MCB, up to 60 V DC and 277 V AC, B curve 1-pole 7 A	TMC 81B 07A	2907484	1
MCB, up to 60 V DC and 277 V AC, B curve 1-pole 8 A	TMC 81B 08A	2907485	1
MCB, up to 60 V DC and 277 V AC, B curve 1-pole 10 A	TMC 81B 10A	2907487	1
MCB, up to 60 V DC and 277 V AC, B curve 1-pole 12 A	TMC 81B 12A	2907488	1
MCB, up to 60 V DC and 277 V AC, B curve 1-pole 13 A	TMC 81B 13A	2907489	1
MCB, up to 60 V DC and 277 V AC, B curve 1-pole 15 A	TMC 81B 15A	2907490	1
MCB, up to 60 V DC and 277 V AC, B curve 1-pole 16 A	TMC 81B 16A	2907491	1
MCB, up to 60 V DC and 277 V AC, B curve 1-pole 20 A	TMC 81B 20A	2907492	1
MCB, up to 60 V DC and 277 V AC, B curve 1-pole 25 A	TMC 81B 25A	2907493	1
MCB, up to 60 V DC and 277 V AC, B curve 1-pole 30 A	TMC 81B 30A	2907494	1
MCB, up to 60 V DC and 277 V AC, B curve 1-pole 32 A	TMC 81B 32A	2907495	1
MCB, up to 60 V DC and 120 V AC, B curve 1-pole 35 A	TMC 81B 35A	2907496	1
MCB, up to 60 V DC and 120 V AC, B curve 1-pole 40 A	TMC 81B 40A	2907497	1
MCB, up to 60 V DC and 120 V AC, B curve 1-pole 50 A	TMC 81B 50A	2907498	1
MCB, up to 60 V DC and 120 V AC, B curve 1-pole 60 A	TMC 81B 60A	2907500	1
MCB, up to 60 V DC and 120 V AC, B curve 1-pole 63 A	TMC 81B 63A	2907501	1
MCB, up to 125 V DC (two poles in series) and 277 V AC (277/480Y, 240D), B curve 2-pole 1 A	TMC 82B 01A	2907502	1
MCB, up to 125 V DC (two poles in series) and 277 V AC (277/480Y, 240D), B curve 2-pole 2 A	TMC 82B 02A	2907503	1
MCB, up to 125 V DC (two poles in series) and 277 V AC (277/480Y, 240D), B curve 2-pole 3 A	TMC 82B 03A	2907504	1
MCB, up to 125 V DC (two poles in series) and 277 V AC (277/480Y, 240D), B curve 2-pole 4 A	TMC 82B 04A	2907505	1
MCB, up to 125 V DC (two poles in series) and 277 V AC (277/480Y, 240D), B curve 2-pole 5 A	TMC 82B 05A	2907506	1
MCB, up to 125 V DC (two poles in series) and 277 V AC (277/480Y, 240D), B curve 2-pole 6 A	TMC 82B 06A	2907507	1
MCB, up to 125 V DC (two poles in series) and 277 V AC (277/480Y, 240D), B curve 2-pole 7 A	TMC 82B 07A	2907508	1
MCB, up to 125 V DC (two poles in series) and 277 V AC (277/480Y, 240D), B curve 2-pole 8 A	TMC 82B 08A	2907510	1
MCB, up to 125 V DC (two poles in series) and 277 V AC (277/480Y, 240D), B curve 2-pole 10 A	TMC 82B 10A	2907511	1
MCB, up to 125 V DC (two poles in series) and 277 V AC (277/480Y, 240D), B curve 2-pole 12 A	TMC 82B 12A	2907512	1
MCB, up to 125 V DC (two poles in series) and 277 V AC (277/480Y, 240D), B curve 2-pole 13 A	TMC 82B 13A	2907513	1
MCB, up to 125 V DC (two poles in series) and 277 V AC (277/480Y, 240D), B curve 2-pole 15 A	TMC 82B 15A	2907514	1
MCB, up to 125 V DC (two poles in series) and 277 V AC (277/480Y, 240D), B curve 2-pole 16 A	TMC 82B 16A	2907515	1
MCB, up to 125 V DC (two poles in series) and 277 V AC (277/480Y, 240D), B curve 2-pole 20 A	TMC 82B 20A	2907516	1
MCB, up to 125 V DC (two poles in series) and 277 V AC (277/480Y, 240D), B curve 2-pole 25 A	TMC 82B 25A	2907530	1
MCB, up to 125 V DC (two poles in series) and 277 V AC (277/480Y, 240D), B curve 2-pole 30 A	TMC 82B 30A	2907531	1
MCB, up to 125 V DC (two poles in series) and 277 V AC (277/480Y, 240D), B curve 2-pole 32 A	TMC 82B 32A	2907532	1
MCB, up to 125 V DC (two poles in series) and 240 V AC (120/240S, 240D), B curve 2-pole 35 A	TMC 82B 35A	2907533	1

Products

Description	Type	Order No.	Pcs./Pkt.
MCB, up to 125 V DC (two poles in series) and 240 V AC (120/240S, 240D), B curve 2-pole 40 A	TMC 82B 40A	2907534	1
MCB, up to 125 V DC (two poles in series) and 240 V AC (120/240S, 240D), B curve 2-pole 50 A	TMC 82B 50A	2907535	1
MCB, up to 125 V DC (two poles in series) and 240 V AC (120/240S, 240D), B curve 2-pole 60 A	TMC 82B 60A	2907536	1
MCB, up to 125 V DC (two poles in series) and 240 V AC (120/240S, 240D), B curve 2-pole 63 A	TMC 82B 63A	2907537	1
MCB, 277 V AC (277/480Y, 240D), B curve 3-pole 1 A	TMC 83B 01A	2907539	1
MCB, 277 V AC (277/480Y, 240D), B curve 3-pole 2 A	TMC 83B 02A	2907540	1
MCB, 277 V AC (277/480Y, 240D), B curve 3-pole 3 A	TMC 83B 03A	2907542	1
MCB, 277 V AC (277/480Y, 240D), B curve 3-pole 4 A	TMC 83B 04A	2907543	1
MCB, 277 V AC (277/480Y, 240D), B curve 3-pole 5 A	TMC 83B 05A	2907544	1
MCB, 277 V AC (277/480Y, 240D), B curve 3-pole 6 A	TMC 83B 06A	2907545	1
MCB, 277 V AC (277/480Y, 240D), B curve 3-pole 7 A	TMC 83B 07A	2907546	1
MCB, 277 V AC (277/480Y, 240D), B curve 3-pole 8 A	TMC 83B 08A	2907547	1
MCB, 277 V AC (277/480Y, 240D), B curve 3-pole 10 A	TMC 83B 10A	2907548	1
MCB, 277 V AC (277/480Y, 240D), B curve 3-pole 12 A	TMC 83B 12A	2907549	1
MCB, 277 V AC (277/480Y, 240D), B curve 3-pole 13 A	TMC 83B 13A	2907550	1
MCB, 277 V AC (277/480Y, 240D), B curve 3-pole 15 A	TMC 83B 15A	2907551	1
MCB, 277 V AC (277/480Y, 240D), B curve 3-pole 16 A	TMC 83B 16A	2907552	1
MCB, 277 V AC (277/480Y, 240D), B curve 3-pole 20 A	TMC 83B 20A	2907553	1
MCB, 277 V AC (277/480Y, 240D), B curve 3-pole 25 A	TMC 83B 25A	2907555	1
MCB, 277 V AC (277/480Y, 240D), B curve 3-pole 30 A	TMC 83B 30A	2907556	1
MCB, 277 V AC (277/480Y, 240D), B curve 3-pole 32 A	TMC 83B 32A	2907557	1
MCB, up to 240 V AC (240D), B curve 3-pole 35 A	TMC 83B 35A	1010309	1
MCB, up to 240 V AC (240D), B curve 3-pole 40 A	TMC 83B 40A	1010308	1
MCB, up to 240 V AC (240D), B curve 3-pole 50 A	TMC 83B 50A	1010307	1
MCB, up to 240 V AC (240D), B curve 3-pole 60 A	TMC 83B 60A	1010306	1
MCB, up to 240 V AC (240D), B curve 3-pole 63 A	TMC 83B 63A	1010286	1
MCB, up to 60 V DC and 277 V AC, C curve 1-pole 1 A	TMC 81C 01A	2907558	1
MCB, up to 60 V DC and 277 V AC, C curve 1-pole 2 A	TMC 81C 02A	2907559	1
MCB, up to 60 V DC and 277 V AC, C curve 1-pole 3 A	TMC 81C 03A	2907560	1
MCB, up to 60 V DC and 277 V AC, C curve 1-pole 4 A	TMC 81C 04A	2907561	1
MCB, up to 60 V DC and 277 V AC, C curve 1-pole 5 A	TMC 81C 05A	2907562	1
MCB, up to 60 V DC and 277 V AC, C curve 1-pole 6 A	TMC 81C 06A	2907563	1
MCB, up to 60 V DC and 277 V AC, C curve 1-pole 7 A	TMC 81C 07A	2907564	1
MCB, up to 60 V DC and 277 V AC, C curve 1-pole 8 A	TMC 81C 08A	2907565	1
MCB, up to 60 V DC and 277 V AC, C curve 1-pole 10 A	TMC 81C 10A	2907566	1
MCB, up to 60 V DC and 277 V AC, C curve 1-pole 12 A	TMC 81C 12A	2907568	1
MCB, up to 60 V DC and 277 V AC, C curve 1-pole 13 A	TMC 81C 13A	2907569	1
MCB, up to 60 V DC and 277 V AC, C curve 1-pole 15 A	TMC 81C 15A	2907571	1
MCB, up to 60 V DC and 277 V AC, C curve 1-pole 16 A	TMC 81C 16A	2907572	1
MCB, up to 60 V DC and 277 V AC, C curve 1-pole 20 A	TMC 81C 20A	2907573	1
MCB, up to 60 V DC and 277 V AC, C curve 1-pole 25 A	TMC 81C 25A	2907574	1
MCB, up to 60 V DC and 277 V AC, C curve 1-pole 30 A	TMC 81C 30A	2907575	1
MCB, up to 60 V DC and 277 V AC, C curve 1-pole 32 A	TMC 81C 32A	2907576	1
MCB, up to 60 V DC and 120 V AC, C curve 1-pole 35 A	TMC 81C 35A	2907577	1
MCB, up to 60 V DC and 120 V AC, C curve 1-pole 40 A	TMC 81C 40A	2907578	1
MCB, up to 60 V DC and 120 V AC, C curve 1-pole 50 A	TMC 81C 50A	2907579	1
MCB, up to 60 V DC and 120 V AC, C curve 1-pole 60 A	TMC 81C 60A	2907580	1
MCB, up to 60 V DC and 120 V AC, C curve 1-pole 63 A	TMC 81C 63A	2907581	1
MCB, up to 125 V DC (two poles in series) and 277 V AC (277/480Y, 240D), C curve 2-pole 1 A	TMC 82C 01A	2907582	1
MCB, up to 125 V DC (two poles in series) and 277 V AC (277/480Y, 240D), C curve 2-pole 2 A	TMC 82C 02A	2907584	1
MCB, up to 125 V DC (two poles in series) and 277 V AC (277/480Y, 240D), C curve 2-pole 3 A	TMC 82C 03A	2907585	1
MCB, up to 125 V DC (two poles in series) and 277 V AC (277/480Y, 240D), C curve 2-pole 4 A	TMC 82C 04A	2907586	1

Products

Description	Type	Order No.	Pcs./Pkt.
MCB, up to 125 V DC (two poles in series) and 277 V AC (277/480Y, 240D), C curve 2-pole 5 A	TMC 82C 05A	2907587	1
MCB, up to 125 V DC (two poles in series) and 277 V AC (277/480Y, 240D), C curve 2-pole 6 A	TMC 82C 06A	2907588	1
MCB, up to 125 V DC (two poles in series) and 277 V AC (277/480Y, 240D), C curve 2-pole 7 A	TMC 82C 07A	2907589	1
MCB, up to 125 V DC (two poles in series) and 277 V AC (277/480Y, 240D), C curve 2-pole 8 A	TMC 82C 08A	2907590	1
MCB, up to 125 V DC (two poles in series) and 277 V AC (277/480Y, 240D), C curve 2-pole 10 A	TMC 82C 10A	2907591	1
MCB, up to 125 V DC (two poles in series) and 277 V AC (277/480Y, 240D), C curve 2-pole 12 A	TMC 82C 12A	2907592	1
MCB, up to 125 V DC (two poles in series) and 277 V AC (277/480Y, 240D), C curve 2-pole 13 A	TMC 82C 13A	2907593	1
MCB, up to 125 V DC (two poles in series) and 277 V AC (277/480Y, 240D), C curve 2-pole 15 A	TMC 82C 15A	2907594	1
MCB, up to 125 V DC (two poles in series) and 277 V AC (277/480Y, 240D), C curve 2-pole 16 A	TMC 82C 16A	2907595	1
MCB, up to 125 V DC (two poles in series) and 277 V AC (277/480Y, 240D), C curve 2-pole 20 A	TMC 82C 20A	2907597	1
MCB, up to 125 V DC (two poles in series) and 277 V AC (277/480Y, 240D), C curve 2-pole 25 A	TMC 82C 25A	2907598	1
MCB, up to 125 V DC (two poles in series) and 277 V AC (277/480Y, 240D), C curve 2-pole 30 A	TMC 82C 30A	2907599	1
MCB, up to 125 V DC (two poles in series) and 277 V AC (277/480Y, 240D), C curve 2-pole 32 A	TMC 82C 32A	2907600	1
MCB, up to 125 V DC (two poles in series) and 240 V AC (120/240S, 240D), C curve 2-pole 35 A	TMC 82C 35A	2907601	1
MCB, up to 125 V DC (two poles in series) and 240 V AC (120/240S, 240D), C curve 2-pole 40 A	TMC 82C 40A	2907602	1
MCB, up to 125 V DC (two poles in series) and 240 V AC (120/240S, 240D), C curve 2-pole 50 A	TMC 82C 50A	2907603	1
MCB, up to 125 V DC (two poles in series) and 240 V AC (120/240S, 240D), C curve 2-pole 60 A	TMC 82C 60A	2907604	1
MCB, up to 125 V DC (two poles in series) and 240 V AC (120/240S, 240D), C curve 2-pole 63 A	TMC 82C 63A	2907605	1
MCB, 277 V AC (277/480Y, 240D), C curve 3-pole 1 A	TMC 83C 01A	2907607	1
MCB, 277 V AC (277/480Y, 240D), C curve 3-pole 2 A	TMC 83C 02A	2907608	1
MCB, 277 V AC (277/480Y, 240D), C curve 3-pole 3 A	TMC 83C 03A	2907609	1
MCB, 277 V AC (277/480Y, 240D), C curve 3-pole 4 A	TMC 83C 04A	2907610	1
MCB, 277 V AC (277/480Y, 240D), C curve 3-pole 5 A	TMC 83C 05A	2907611	1
MCB, 277 V AC (277/480Y, 240D), C curve 3-pole 6 A	TMC 83C 06A	2907612	1
MCB, 277 V AC (277/480Y, 240D), C curve 3-pole 7 A	TMC 83C 07A	2907613	1
MCB, 277 V AC (277/480Y, 240D), C curve 3-pole 8 A	TMC 83C 08A	2907614	1
MCB, 277 V AC (277/480Y, 240D), C curve 3-pole 10 A	TMC 83C 10A	2907615	1
MCB, 277 V AC (277/480Y, 240D), C curve 3-pole 12 A	TMC 83C 12A	2907616	1
MCB, 277 V AC (277/480Y, 240D), C curve 3-pole 13 A	TMC 83C 13A	2907617	1
MCB, 277 V AC (277/480Y, 240D), C curve 3-pole 15 A	TMC 83C 15A	2907618	1
MCB, 277 V AC (277/480Y, 240D), C curve 3-pole 16 A	TMC 83C 16A	2907620	1
MCB, 277 V AC (277/480Y, 240D), C curve 3-pole 20 A	TMC 83C 20A	2907621	1
MCB, 277 V AC (277/480Y, 240D), C curve 3-pole 25 A	TMC 83C 25A	2907623	1
MCB, 277 V AC (277/480Y, 240D), C curve 3-pole 30 A	TMC 83C 30A	2907624	1
MCB, 277 V AC (277/480Y, 240D), C curve 3-pole 32 A	TMC 83C 32A	2907625	1
MCB, up to 240 V AC (240D), C curve 3-pole 35 A	TMC 83C 35A	1010303	1
MCB, up to 240 V AC (240D), C curve 3-pole 40 A	TMC 83C 40A	1010305	1
MCB, up to 240 V AC (240D), C curve 3-pole 50 A	TMC 83C 50A	1010302	1
MCB, up to 240 V AC (240D), C curve 3-pole 60 A	TMC 83C 60A	1010301	1
MCB, up to 240 V AC (240D), C curve 3-pole 63 A	TMC 83C 63A	1010291	1
MCB, up to 60 V DC and 277 V AC, D curve 1-pole 1 A	TMC 81D 01A	2907626	1
MCB, up to 60 V DC and 277 V AC, D curve 1-pole 2 A	TMC 81D 02A	2907627	1
MCB, up to 60 V DC and 277 V AC, D curve 1-pole 3 A	TMC 81D 03A	2907628	1
MCB, up to 60 V DC and 277 V AC, D curve 1-pole 4 A	TMC 81D 04A	2907629	1
MCB, up to 60 V DC and 277 V AC, D curve 1-pole 5 A	TMC 81D 05A	2907630	1
MCB, up to 60 V DC and 277 V AC, D curve 1-pole 6 A	TMC 81D 06A	2907631	1
MCB, up to 60 V DC and 277 V AC, D curve 1-pole 7 A	TMC 81D 07A	2907632	1
MCB, up to 60 V DC and 277 V AC, D curve 1-pole 8 A	TMC 81D 08A	2907633	1
MCB, up to 60 V DC and 277 V AC, D curve 1-pole 10 A	TMC 81D 10A	2907634	1
MCB, up to 60 V DC and 277 V AC, D curve 1-pole 12 A	TMC 81D 12A	2907636	1
MCB, up to 60 V DC and 277 V AC, D curve 1-pole 13 A	TMC 81D 13A	2907637	1
MCB, up to 60 V DC and 277 V AC, D curve 1-pole 15 A	TMC 81D 15A	2907638	1

Products

Description	Type	Order No.	Pcs./Pkt.
MCB, up to 60 V DC and 277 V AC, D curve 1-pole 16 A	TMC 81D 16A	2907639	1
MCB, up to 60 V DC and 277 V AC, D curve 1-pole 20 A	TMC 81D 20A	2907640	1
MCB, up to 60 V DC and 277 V AC, D curve 1-pole 25 A	TMC 81D 25A	2907641	1
MCB, up to 60 V DC and 277 V AC, D curve 1-pole 30 A	TMC 81D 30A	2907642	1
MCB, up to 60 V DC and 277 V AC, D curve 1-pole 32 A	TMC 81D 32A	2907643	1
MCB, up to 60 V DC and 120 V AC, D curve 1-pole 35 A	TMC 81D 35A	2907644	1
MCB, up to 60 V DC and 120 V AC, D curve 1-pole 40 A	TMC 81D 40A	2907645	1
MCB, up to 60 V DC and 120 V AC, D curve 1-pole 50 A	TMC 81D 50A	2907646	1
MCB, up to 60 V DC and 120 V AC, D curve 1-pole 60 A	TMC 81D 60A	2907647	1
MCB, up to 60 V DC and 120 V AC, D curve 1-pole 63 A	TMC 81D 63A	2907649	1
MCB, up to 125 V DC (two poles in series) and 277 V AC (277/480Y, 240D), D curve 2-pole 1 A	TMC 82D 01A	2907650	1
MCB, up to 125 V DC (two poles in series) and 277 V AC (277/480Y, 240D), D curve 2-pole 2 A	TMC 82D 02A	2907652	1
MCB, up to 125 V DC (two poles in series) and 277 V AC (277/480Y, 240D), D curve 2-pole 3 A	TMC 82D 03A	2907653	1
MCB, up to 125 V DC (two poles in series) and 277 V AC (277/480Y, 240D), D curve 2-pole 4 A	TMC 82D 04A	2907654	1
MCB, up to 125 V DC (two poles in series) and 277 V AC (277/480Y, 240D), D curve 2-pole 5 A	TMC 82D 05A	2907655	1
MCB, up to 125 V DC (two poles in series) and 277 V AC (277/480Y, 240D), D curve 2-pole 6 A	TMC 82D 06A	2907656	1
MCB, up to 125 V DC (two poles in series) and 277 V AC (277/480Y, 240D), D curve 2-pole 7 A	TMC 82D 07A	2907657	1
MCB, up to 125 V DC (two poles in series) and 277 V AC (277/480Y, 240D), D curve 2-pole 8 A	TMC 82D 08A	2907658	1
MCB, up to 125 V DC (two poles in series) and 277 V AC (277/480Y, 240D), D curve 2-pole 10 A	TMC 82D 10A	2907659	1
MCB, up to 125 V DC (two poles in series) and 277 V AC (277/480Y, 240D), D curve 2-pole 12 A	TMC 82D 12A	2907660	1
MCB, up to 125 V DC (two poles in series) and 277 V AC (277/480Y, 240D), D curve 2-pole 13 A	TMC 82D 13A	2907661	1
MCB, up to 125 V DC (two poles in series) and 277 V AC (277/480Y, 240D), D curve 2-pole 15 A	TMC 82D 15A	2907662	1
MCB, up to 125 V DC (two poles in series) and 277 V AC (277/480Y, 240D), D curve 2-pole 16 A	TMC 82D 16A	2907663	1
MCB, up to 125 V DC (two poles in series) and 277 V AC (277/480Y, 240D), D curve 2-pole 20 A	TMC 82D 20A	2907665	1
MCB, up to 125 V DC (two poles in series) and 277 V AC (277/480Y, 240D), D curve 2-pole 25 A	TMC 82D 25A	2907666	1
MCB, up to 125 V DC (two poles in series) and 277 V AC (277/480Y, 240D), D curve 2-pole 30 A	TMC 82D 30A	2907667	1
MCB, up to 125 V DC (two poles in series) and 277 V AC (277/480Y, 240D), D curve 2-pole 32 A	TMC 82D 32A	2907668	1
MCB, up to 125 V DC (two poles in series) and 240 V AC (120/240S, 240D), D curve 2-pole 35 A	TMC 82D 35A	2907669	1
MCB, up to 125 V DC (two poles in series) and 240 V AC (120/240S, 240D), D curve 2-pole 40 A	TMC 82D 40A	2907670	1
MCB, up to 125 V DC (two poles in series) and 240 V AC (120/240S, 240D), D curve 2-pole 50 A	TMC 82D 50A	2907671	1
MCB, up to 125 V DC (two poles in series) and 240 V AC (120/240S, 240D), D curve 2-pole 60 A	TMC 82D 60A	2907672	1
MCB, up to 125 V DC (two poles in series) and 240 V AC (120/240S, 240D), D curve 2-pole 63 A	TMC 82D 63A	2907673	1
MCB, 277 V AC (277/480Y, 240D), D curve 3-pole 1 A	TMC 83D 01A	2907674	1
MCB, 277 V AC (277/480Y, 240D), D curve 3-pole 2 A	TMC 83D 02A	2907675	1
MCB, 277 V AC (277/480Y, 240D), D curve 3-pole 3 A	TMC 83D 03A	2907676	1
MCB, 277 V AC (277/480Y, 240D), D curve 3-pole 4 A	TMC 83D 04A	2907678	1
MCB, 277 V AC (277/480Y, 240D), D curve 3-pole 5 A	TMC 83D 05A	2907679	1
MCB, 277 V AC (277/480Y, 240D), D curve 3-pole 6 A	TMC 83D 06A	2907681	1
MCB, 277 V AC (277/480Y, 240D), D curve 3-pole 7 A	TMC 83D 07A	2907682	1
MCB, 277 V AC (277/480Y, 240D), D curve 3-pole 8 A	TMC 83D 08A	2907683	1
MCB, 277 V AC (277/480Y, 240D), D curve 3-pole 10 A	TMC 83D 10A	2907684	1
MCB, 277 V AC (277/480Y, 240D), D curve 3-pole 12 A	TMC 83D 12A	2907685	1
MCB, 277 V AC (277/480Y, 240D), D curve 3-pole 13 A	TMC 83D 13A	2907686	1
MCB, 277 V AC (277/480Y, 240D), D curve 3-pole 15 A	TMC 83D 15A	2907687	1
MCB, 277 V AC (277/480Y, 240D), D curve 3-pole 16 A	TMC 83D 16A	2907688	1
MCB, 277 V AC (277/480Y, 240D), D curve 3-pole 20 A	TMC 83D 20A	2907689	1
MCB, 277 V AC (277/480Y, 240D), D curve 3-pole 25 A	TMC 83D 25A	2907690	1
MCB, 277 V AC (277/480Y, 240D), D curve 3-pole 30 A	TMC 83D 30A	2907691	1
MCB, 277 V AC (277/480Y, 240D), D curve 3-pole 32 A	TMC 83D 32A	2907692	1
MCB, up to 240 V AC (240D), D curve 3-pole 35 A	TMC 83D 35A	1010290	1
MCB, up to 240 V AC (240D), D curve 3-pole 40 A	TMC 83D 40A	1010289	1

Products

Description	Type	Order No.	Pcs./Pkt.
MCB, up to 240 V AC (240D), D curve 3-pole 50 A	TMC 83D 50A	1010284	1
MCB, up to 240 V AC (240D), D curve 3-pole 60 A	TMC 83D 60A	1010288	1
MCB, up to 240 V AC (240D), D curve 3-pole 63 A	TMC 83D 63A	1010287	1

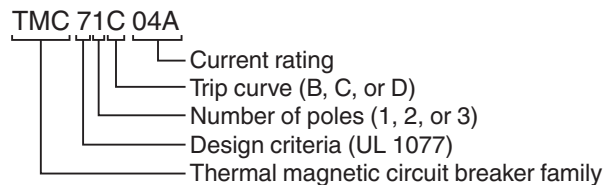

Products

Description	Type	Order No.	Pcs./Pkt.
MCB, up to 60 V DC and 277 V AC, B curve 1-pole 1 A	TMC 71B 01A	1011962	1
MCB, up to 60 V DC and 277 V AC, B curve 1-pole 2 A	TMC 71B 02A	1019909	1
MCB, up to 60 V DC and 277 V AC, B curve 1-pole 3 A	TMC 71B 03A	1019910	1
MCB, up to 60 V DC and 277 V AC, B curve 1-pole 4 A	TMC 71B 04A	1019911	1
MCB, up to 60 V DC and 277 V AC, B curve 1-pole 5 A	TMC 71B 05A	1019912	1
MCB, up to 60 V DC and 277 V AC, B curve 1-pole 6 A	TMC 71B 06A	1019913	1
MCB, up to 60 V DC and 277 V AC, B curve 1-pole 7 A	TMC 71B 07A	1019914	1
MCB, up to 60 V DC and 277 V AC, B curve 1-pole 8 A	TMC 71B 08A	1019915	1
MCB, up to 60 V DC and 277 V AC, B curve 1-pole 10 A	TMC 71B 10A	1019916	1
MCB, up to 60 V DC and 277 V AC, B curve 1-pole 12 A	TMC 71B 12A	1019917	1
MCB, up to 60 V DC and 277 V AC, B curve 1-pole 13 A	TMC 71B 13A	1019918	1
MCB, up to 60 V DC and 277 V AC, B curve 1-pole 15 A	TMC 71B 15A	1019919	1
MCB, up to 60 V DC and 277 V AC, B curve 1-pole 16 A	TMC 71B 16A	1019920	1
MCB, up to 60 V DC and 277 V AC, B curve 1-pole 20 A	TMC 71B 20A	1019921	1
MCB, up to 60 V DC and 277 V AC, B curve 1-pole 25 A	TMC 71B 25A	1019922	1
MCB, up to 60 V DC and 277 V AC, B curve 1-pole 30 A	TMC 71B 30A	1019923	1
MCB, up to 60 V DC and 277 V AC, B curve 1-pole 32 A	TMC 71B 32A	1019924	1
MCB, up to 60 V DC and 277 V AC, B curve 1-pole 40 A	TMC 71B 40A	1019925	1
MCB, up to 60 V DC and 277 V AC, B curve 1-pole 50 A	TMC 71B 50A	1019926	1
MCB, up to 60 V DC and 277 V AC, B curve 1-pole 60 A	TMC 71B 60A	1019927	1
MCB, up to 60 V DC and 277 V AC, B curve 1-pole 63 A	TMC 71B 63A	1019928	1
MCB, up to 125 V DC (two poles in series) and 277 V AC (277/480Y, 240D), B curve 2-pole 1 A	TMC 72B 01A	1019930	1
MCB, up to 125 V DC (two poles in series) and 277 V AC (277/480Y, 240D), B curve 2-pole 2 A	TMC 72B 02A	1019931	1
MCB, up to 125 V DC (two poles in series) and 277 V AC (277/480Y, 240D), B curve 2-pole 3 A	TMC 72B 03A	1019932	1
MCB, up to 125 V DC (two poles in series) and 277 V AC (277/480Y, 240D), B curve 2-pole 4 A	TMC 72B 04A	1019933	1
MCB, up to 125 V DC (two poles in series) and 277 V AC (277/480Y, 240D), B curve 2-pole 5 A	TMC 72B 05A	1019934	1
MCB, up to 125 V DC (two poles in series) and 277 V AC (277/480Y, 240D), B curve 2-pole 6 A	TMC 72B 06A	1019935	1
MCB, up to 125 V DC (two poles in series) and 277 V AC (277/480Y, 240D), B curve 2-pole 7 A	TMC 72B 07A	1019936	1
MCB, up to 125 V DC (two poles in series) and 277 V AC (277/480Y, 240D), B curve 2-pole 8 A	TMC 72B 08A	1019937	1
MCB, up to 125 V DC (two poles in series) and 277 V AC (277/480Y, 240D), B curve 2-pole 10 A	TMC 72B 10A	1019938	1
MCB, up to 125 V DC (two poles in series) and 277 V AC (277/480Y, 240D), B curve 2-pole 12 A	TMC 72B 12A	1019939	1
MCB, up to 125 V DC (two poles in series) and 277 V AC (277/480Y, 240D), B curve 2-pole 13 A	TMC 72B 13A	1019940	1
MCB, up to 125 V DC (two poles in series) and 277 V AC (277/480Y, 240D), B curve 2-pole 15 A	TMC 72B 15A	1019941	1
MCB, up to 125 V DC (two poles in series) and 277 V AC (277/480Y, 240D), B curve 2-pole 16 A	TMC 72B 16A	1019942	1
MCB, up to 125 V DC (two poles in series) and 277 V AC (277/480Y, 240D), B curve 2-pole 20 A	TMC 72B 20A	1019943	1
MCB, up to 125 V DC (two poles in series) and 277 V AC (277/480Y, 240D), B curve 2-pole 25 A	TMC 72B 25A	1019944	1

Products

Description	Type	Order No.	Pcs./Pkt.
MCB, up to 125 V DC (two poles in series) and 277 V AC (277/480Y, 240D), B curve 2-pole 30 A	TMC 72B 30A	1019945	1
MCB, up to 125 V DC (two poles in series) and 277 V AC (277/480Y, 240D), B curve 2-pole 32 A	TMC 72B 32A	1019946	1
MCB, up to 125 V DC (two poles in series) and 240 V AC (120/240S, 240D), B curve 2-pole 40 A	TMC 72B 40A	1019947	1
MCB, up to 125 V DC (two poles in series) and 240 V AC (120/240S, 240D), B curve 2-pole 50 A	TMC 72B 50A	1019948	1
MCB, up to 125 V DC (two poles in series) and 240 V AC (120/240S, 240D), B curve 2-pole 60 A	TMC 72B 60A	1019949	1
MCB, up to 125 V DC (two poles in series) and 240 V AC (120/240S, 240D), B curve 2-pole 63 A	TMC 72B 63A	1019950	1
MCB, 277 V AC (277/480Y, 240D), B curve 3-pole 1 A	TMC 73B 01A	1019951	1
MCB, 277 V AC (277/480Y, 240D), B curve 3-pole 2 A	TMC 73B 02A	1019952	1
MCB, 277 V AC (277/480Y, 240D), B curve 3-pole 3 A	TMC 73B 03A	1019953	1
MCB, 277 V AC (277/480Y, 240D), B curve 3-pole 4 A	TMC 73B 04A	1019954	1
MCB, 277 V AC (277/480Y, 240D), B curve 3-pole 5 A	TMC 73B 05A	1019955	1
MCB, 277 V AC (277/480Y, 240D), B curve 3-pole 6 A	TMC 73B 06A	1019956	1
MCB, 277 V AC (277/480Y, 240D), B curve 3-pole 7 A	TMC 73B 07A	1019957	1
MCB, 277 V AC (277/480Y, 240D), B curve 3-pole 8 A	TMC 73B 08A	1019958	1
MCB, 277 V AC (277/480Y, 240D), B curve 3-pole 10 A	TMC 73B 10A	1019959	1
MCB, 277 V AC (277/480Y, 240D), B curve 3-pole 12 A	TMC 73B 12A	1019960	1
MCB, 277 V AC (277/480Y, 240D), B curve 3-pole 13 A	TMC 73B 13A	1019961	1
MCB, 277 V AC (277/480Y, 240D), B curve 3-pole 15 A	TMC 73B 15A	1019962	1
MCB, 277 V AC (277/480Y, 240D), B curve 3-pole 16 A	TMC 73B 16A	1019963	1
MCB, 277 V AC (277/480Y, 240D), B curve 3-pole 20 A	TMC 73B 20A	1019964	1
MCB, 277 V AC (277/480Y, 240D), B curve 3-pole 25 A	TMC 73B 25A	1019965	1
MCB, 277 V AC (277/480Y, 240D), B curve 3-pole 30 A	TMC 73B 30A	1019966	1
MCB, 277 V AC (277/480Y, 240D), B curve 3-pole 32 A	TMC 73B 32A	1019967	1
MCB, 277 V AC (277/480Y, 240D), B curve 3-pole 40 A	TMC 73B 40A	1019968	1
MCB, 277 V AC (277/480Y, 240D), B curve 3-pole 50 A	TMC 73B 50A	1019969	1
MCB, 277 V AC (277/480Y, 240D), B curve 3-pole 60 A	TMC 73B 60A	1019970	1
MCB, 277 V AC (277/480Y, 240D), B curve 3-pole 63 A	TMC 73B 63A	1019971	1
MCB, up to 60 V DC and 277 V AC, C curve 1-pole 1 A	TMC 71C 01A	1019972	1
MCB, up to 60 V DC and 277 V AC, C curve 1-pole 2 A	TMC 71C 02A	1019973	1
MCB, up to 60 V DC and 277 V AC, C curve 1-pole 3 A	TMC 71C 03A	1019974	1
MCB, up to 60 V DC and 277 V AC, C curve 1-pole 4 A	TMC 71C 04A	1019975	1
MCB, up to 60 V DC and 277 V AC, C curve 1-pole 5 A	TMC 71C 05A	1019976	1
MCB, up to 60 V DC and 277 V AC, C curve 1-pole 6 A	TMC 71C 06A	1019977	1
MCB, up to 60 V DC and 277 V AC, C curve 1-pole 7 A	TMC 71C 07A	1019978	1
MCB, up to 60 V DC and 277 V AC, C curve 1-pole 8 A	TMC 71C 08A	1019979	1
MCB, up to 60 V DC and 277 V AC, C curve 1-pole 10 A	TMC 71C 10A	1019980	1
MCB, up to 60 V DC and 277 V AC, C curve 1-pole 12 A	TMC 71C 12A	1019981	1
MCB, up to 60 V DC and 277 V AC, C curve 1-pole 13 A	TMC 71C 13A	1019982	1
MCB, up to 60 V DC and 277 V AC, C curve 1-pole 15 A	TMC 71C 15A	1019983	1
MCB, up to 60 V DC and 277 V AC, C curve 1-pole 16 A	TMC 71C 16A	1019984	1
MCB, up to 60 V DC and 277 V AC, C curve 1-pole 20 A	TMC 71C 20A	1019985	1
MCB, up to 60 V DC and 277 V AC, C curve 1-pole 25 A	TMC 71C 25A	1019986	1
MCB, up to 60 V DC and 277 V AC, C curve 1-pole 30 A	TMC 71C 30A	1019987	1
MCB, up to 60 V DC and 277 V AC, C curve 1-pole 32 A	TMC 71C 32A	1019988	1
MCB, up to 60 V DC and 277 V AC, C curve 1-pole 40 A	TMC 71C 40A	1019989	1
MCB, up to 60 V DC and 277 V AC, C curve 1-pole 50 A	TMC 71C 50A	1019990	1
MCB, up to 60 V DC and 277 V AC, C curve 1-pole 60 A	TMC 71C 60A	1019991	1
MCB, up to 60 V DC and 277 V AC, C curve 1-pole 63 A	TMC 71C 63A	1019992	1
MCB, up to 125 V DC (two poles in series) and 277 V AC (277/480Y, 240D), C curve 2-pole 1 A	TMC 72C 01A	1019994	1
MCB, up to 125 V DC (two poles in series) and 277 V AC (277/480Y, 240D), C curve 2-pole 2 A	TMC 72C 02A	1019995	1
MCB, up to 125 V DC (two poles in series) and 277 V AC (277/480Y, 240D), C curve 2-pole 3 A	TMC 72C 03A	1019996	1
MCB, up to 125 V DC (two poles in series) and 277 V AC (277/480Y, 240D), C curve 2-pole 4 A	TMC 72C 04A	1019997	1

Products

Description	Type	Order No.	Pcs./Pkt.
MCB, up to 125 V DC (two poles in series) and 277 V AC (277/480Y, 240D), C curve 2-pole 5 A	TMC 72C 05A	1019998	1
MCB, up to 125 V DC (two poles in series) and 277 V AC (277/480Y, 240D), C curve 2-pole 6 A	TMC 72C 06A	1019999	1
MCB, up to 125 V DC (two poles in series) and 277 V AC (277/480Y, 240D), C curve 2-pole 7 A	TMC 72C 07A	1020000	1
MCB, up to 125 V DC (two poles in series) and 277 V AC (277/480Y, 240D), C curve 2-pole 8 A	TMC 72C 08A	1020001	1
MCB, up to 125 V DC (two poles in series) and 277 V AC (277/480Y, 240D), C curve 2-pole 10 A	TMC 72C 10A	1020002	1
MCB, up to 125 V DC (two poles in series) and 277 V AC (277/480Y, 240D), C curve 2-pole 12 A	TMC 72C 12A	1020003	1
MCB, up to 125 V DC (two poles in series) and 277 V AC (277/480Y, 240D), C curve 2-pole 13 A	TMC 72C 13A	1020004	1
MCB, up to 125 V DC (two poles in series) and 277 V AC (277/480Y, 240D), C curve 2-pole 15 A	TMC 72C 15A	1020005	1
MCB, up to 125 V DC (two poles in series) and 277 V AC (277/480Y, 240D), C curve 2-pole 16 A	TMC 72C 16A	1020006	1
MCB, up to 125 V DC (two poles in series) and 277 V AC (277/480Y, 240D), C curve 2-pole 20 A	TMC 72C 20A	1020007	1
MCB, up to 125 V DC (two poles in series) and 277 V AC (277/480Y, 240D), C curve 2-pole 25 A	TMC 72C 25A	1020008	1
MCB, up to 125 V DC (two poles in series) and 277 V AC (277/480Y, 240D), C curve 2-pole 30 A	TMC 72C 30A	1020009	1
MCB, up to 125 V DC (two poles in series) and 277 V AC (277/480Y, 240D), C curve 2-pole 32 A	TMC 72C 32A	1020010	1
MCB, up to 125 V DC (two poles in series) and 240 V AC (120/240S, 240D), C curve 2-pole 40 A	TMC 72C 40A	1020011	1
MCB, up to 125 V DC (two poles in series) and 240 V AC (120/240S, 240D), C curve 2-pole 50 A	TMC 72C 50A	1020012	1
MCB, up to 125 V DC (two poles in series) and 240 V AC (120/240S, 240D), C curve 2-pole 60 A	TMC 72C 60A	1020013	1
MCB, up to 125 V DC (two poles in series) and 240 V AC (120/240S, 240D), C curve 2-pole 63 A	TMC 72C 63A	1020014	1
MCB, 277 V AC (277/480Y, 240D), C curve 3-pole 1 A	TMC 73C 01A	1020015	1
MCB, 277 V AC (277/480Y, 240D), C curve 3-pole 2 A	TMC 73C 02A	1020016	1
MCB, 277 V AC (277/480Y, 240D), C curve 3-pole 3 A	TMC 73C 03A	1020017	1
MCB, 277 V AC (277/480Y, 240D), C curve 3-pole 4 A	TMC 73C 04A	1020018	1
MCB, 277 V AC (277/480Y, 240D), C curve 3-pole 5 A	TMC 73C 05A	1020019	1
MCB, 277 V AC (277/480Y, 240D), C curve 3-pole 6 A	TMC 73C 06A	1020020	1
MCB, 277 V AC (277/480Y, 240D), C curve 3-pole 7 A	TMC 73C 07A	1020021	1
MCB, 277 V AC (277/480Y, 240D), C curve 3-pole 8 A	TMC 73C 08A	1020022	1
MCB, 277 V AC (277/480Y, 240D), C curve 3-pole 10 A	TMC 73C 10A	1020023	1
MCB, 277 V AC (277/480Y, 240D), C curve 3-pole 12 A	TMC 73C 12A	1020024	1
MCB, 277 V AC (277/480Y, 240D), C curve 3-pole 13 A	TMC 73C 13A	1020025	1
MCB, 277 V AC (277/480Y, 240D), C curve 3-pole 15 A	TMC 73C 15A	1020026	1
MCB, 277 V AC (277/480Y, 240D), C curve 3-pole 16 A	TMC 73C 16A	1020027	1
MCB, 277 V AC (277/480Y, 240D), C curve 3-pole 20 A	TMC 73C 20A	1020028	1
MCB, 277 V AC (277/480Y, 240D), C curve 3-pole 25 A	TMC 73C 25A	1020029	1
MCB, 277 V AC (277/480Y, 240D), C curve 3-pole 30 A	TMC 73C 30A	1020030	1
MCB, 277 V AC (277/480Y, 240D), C curve 3-pole 32 A	TMC 73C 32A	1020031	1
MCB, 277 V AC (277/480Y, 240D), C curve 3-pole 40 A	TMC 73C 40A	1020032	1
MCB, 277 V AC (277/480Y, 240D), C curve 3-pole 50 A	TMC 73C 50A	1020033	1
MCB, 277 V AC (277/480Y, 240D), C curve 3-pole 60 A	TMC 73C 60A	1020035	1
MCB, 277 V AC (277/480Y, 240D), C curve 3-pole 63 A	TMC 73C 63A	1020036	1
MCB, up to 60 V DC and 277 V AC, D curve 1-pole 1 A	TMC 71D 01A	1020037	1
MCB, up to 60 V DC and 277 V AC, D curve 1-pole 2 A	TMC 71D 02A	1020038	1
MCB, up to 60 V DC and 277 V AC, D curve 1-pole 3 A	TMC 71D 03A	1020039	1
MCB, up to 60 V DC and 277 V AC, D curve 1-pole 4 A	TMC 71D 04A	1020040	1
MCB, up to 60 V DC and 277 V AC, D curve 1-pole 5 A	TMC 71D 05A	1020041	1
MCB, up to 60 V DC and 277 V AC, D curve 1-pole 6 A	TMC 71D 06A	1020042	1
MCB, up to 60 V DC and 277 V AC, D curve 1-pole 7 A	TMC 71D 07A	1020043	1
MCB, up to 60 V DC and 277 V AC, D curve 1-pole 8 A	TMC 71D 08A	1020044	1
MCB, up to 60 V DC and 277 V AC, D curve 1-pole 10 A	TMC 71D 10A	1020045	1
MCB, up to 60 V DC and 277 V AC, D curve 1-pole 12 A	TMC 71D 12A	1020046	1
MCB, up to 60 V DC and 277 V AC, D curve 1-pole 13 A	TMC 71D 13A	1020048	1
MCB, up to 60 V DC and 277 V AC, D curve 1-pole 15 A	TMC 71D 15A	1020049	1
MCB, up to 60 V DC and 277 V AC, D curve 1-pole 16 A	TMC 71D 16A	1020051	1
MCB, up to 60 V DC and 277 V AC, D curve 1-pole 20 A	TMC 71D 20A	1020052	1

Products

Description	Type	Order No.	Pcs./Pkt.
MCB, up to 60 V DC and 277 V AC, D curve 1-pole 25 A	TMC 71D 25A	1020053	1
MCB, up to 60 V DC and 277 V AC, D curve 1-pole 30 A	TMC 71D 30A	1020054	1
MCB, up to 60 V DC and 277 V AC, D curve 1-pole 32 A	TMC 71D 32A	1020055	1
MCB, up to 60 V DC and 277 V AC, D curve 1-pole 40 A	TMC 71D 40A	1020056	1
MCB, up to 60 V DC and 277 V AC, D curve 1-pole 50 A	TMC 71D 50A	1020057	1
MCB, up to 60 V DC and 277 V AC, D curve 1-pole 60 A	TMC 71D 60A	1020058	1
MCB, up to 60 V DC and 277 V AC, D curve 1-pole 63 A	TMC 71D 63A	1020059	1
MCB, up to 125 V DC (two poles in series) and 277 V AC (277/480Y, 240D), D curve 2-pole 1 A	TMC 72D 01A	1020060	1
MCB, up to 125 V DC (two poles in series) and 277 V AC (277/480Y, 240D), D curve 2-pole 2 A	TMC 72D 02A	1020061	1
MCB, up to 125 V DC (two poles in series) and 277 V AC (277/480Y, 240D), D curve 2-pole 3 A	TMC 72D 03A	1020062	1
MCB, up to 125 V DC (two poles in series) and 277 V AC (277/480Y, 240D), D curve 2-pole 4 A	TMC 72D 04A	1020064	1
MCB, up to 125 V DC (two poles in series) and 277 V AC (277/480Y, 240D), D curve 2-pole 5 A	TMC 72D 05A	1020065	1
MCB, up to 125 V DC (two poles in series) and 277 V AC (277/480Y, 240D), D curve 2-pole 6 A	TMC 72D 06A	1020066	1
MCB, up to 125 V DC (two poles in series) and 277 V AC (277/480Y, 240D), D curve 2-pole 7 A	TMC 72D 07A	1020067	1
MCB, up to 125 V DC (two poles in series) and 277 V AC (277/480Y, 240D), D curve 2-pole 8 A	TMC 72D 08A	1020068	1
MCB, up to 125 V DC (two poles in series) and 277 V AC (277/480Y, 240D), D curve 2-pole 10 A	TMC 72D 10A	1020069	1
MCB, up to 125 V DC (two poles in series) and 277 V AC (277/480Y, 240D), D curve 2-pole 12 A	TMC 72D 12A	1020070	1
MCB, up to 125 V DC (two poles in series) and 277 V AC (277/480Y, 240D), D curve 2-pole 13 A	TMC 72D 13A	1020071	1
MCB, up to 125 V DC (two poles in series) and 277 V AC (277/480Y, 240D), D curve 2-pole 15 A	TMC 72D 15A	1020072	1
MCB, up to 125 V DC (two poles in series) and 277 V AC (277/480Y, 240D), D curve 2-pole 16 A	TMC 72D 16A	1020073	1
MCB, up to 125 V DC (two poles in series) and 277 V AC (277/480Y, 240D), D curve 2-pole 20 A	TMC 72D 20A	1020074	1
MCB, up to 125 V DC (two poles in series) and 277 V AC (277/480Y, 240D), D curve 2-pole 25 A	TMC 72D 25A	1020075	1
MCB, up to 125 V DC (two poles in series) and 277 V AC (277/480Y, 240D), D curve 2-pole 30 A	TMC 72D 30A	1020076	1
MCB, up to 125 V DC (two poles in series) and 277 V AC (277/480Y, 240D), D curve 2-pole 32 A	TMC 72D 32A	1020077	1
MCB, up to 125 V DC (two poles in series) and 277 V AC (277/480Y, 240D), D curve 2-pole 40 A	TMC 72D 40A	1020078	1
MCB, up to 125 V DC (two poles in series) and 277 V AC (277/480Y, 240D), D curve 2-pole 50 A	TMC 72D 50A	1020079	1
MCB, up to 125 V DC (two poles in series) and 277 V AC (277/480Y, 240D), D curve 2-pole 60 A	TMC 72D 60A	1020080	1
MCB, up to 125 V DC (two poles in series) and 277 V AC (277/480Y, 240D), D curve 2-pole 63 A	TMC 72D 63A	1020081	1
MCB, 277 V AC (277/480Y, 240D), D curve 3-pole 1 A	TMC 73D 01A	1020082	1
MCB, 277 V AC (277/480Y, 240D), D curve 3-pole 2 A	TMC 73D 02A	1020083	1
MCB, 277 V AC (277/480Y, 240D), D curve 3-pole 3 A	TMC 73D 03A	1020084	1
MCB, 277 V AC (277/480Y, 240D), D curve 3-pole 4 A	TMC 73D 04A	1020085	1
MCB, 277 V AC (277/480Y, 240D), D curve 3-pole 5 A	TMC 73D 05A	1020086	1
MCB, 277 V AC (277/480Y, 240D), D curve 3-pole 6 A	TMC 73D 06A	1020087	1
MCB, 277 V AC (277/480Y, 240D), D curve 3-pole 7 A	TMC 73D 07A	1020088	1
MCB, 277 V AC (277/480Y, 240D), D curve 3-pole 8 A	TMC 73D 08A	1020090	1
MCB, 277 V AC (277/480Y, 240D), D curve 3-pole 10 A	TMC 73D 10A	1020091	1
MCB, 277 V AC (277/480Y, 240D), D curve 3-pole 12 A	TMC 73D 12A	1020093	1
MCB, 277 V AC (277/480Y, 240D), D curve 3-pole 13 A	TMC 73D 13A	1020094	1
MCB, 277 V AC (277/480Y, 240D), D curve 3-pole 15 A	TMC 73D 15A	1020095	1
MCB, 277 V AC (277/480Y, 240D), D curve 3-pole 16 A	TMC 73D 16A	1020096	1
MCB, 277 V AC (277/480Y, 240D), D curve 3-pole 20 A	TMC 73D 20A	1020097	1
MCB, 277 V AC (277/480Y, 240D), D curve 3-pole 25 A	TMC 73D 25A	1020098	1
MCB, 277 V AC (277/480Y, 240D), D curve 3-pole 30 A	TMC 73D 30A	1020099	1
MCB, 277 V AC (277/480Y, 240D), D curve 3-pole 32 A	TMC 73D 32A	1020100	1
MCB, 277 V AC (277/480Y, 240D), D curve 3-pole 40 A	TMC 73D 40A	1020101	1
MCB, 277 V AC (277/480Y, 240D), D curve 3-pole 50 A	TMC 73D 50A	1020103	1
MCB, 277 V AC (277/480Y, 240D), D curve 3-pole 60 A	TMC 73D 60A	1020104	1
MCB, 277 V AC (277/480Y, 240D), D curve 3-pole 63 A	TMC 73D 63A	1020105	1

3 Technical data

General data

Ambient temperature, operating	-35°C ... 70°C (-31°F ... 158°F)
Degree of protection	IP20
Weight (approximate)	
TMC 8...	131 g per pole
TMC 7...	116 g per pole
Installation	NS35 rail (EN 60715)
Conductor cross section	1 ... 35 mm ² /18 ... 2 AWG ¹
Connection type	Screw-clamp terminals
Conductor tightening torque, maximum	2 Nm (17.7 lb _F -in.)

¹ Use copper wire only.

Electrical data

Nominal voltage, U _N	See product description for specifics for each model
Nominal current	See product description for specifics for each model



NOTE:

Current ratings are 0.80 of nominal current when mounted side by side.

Service life

Mechanical	20,000 cycles
Electrical	6,000 cycles

Conformance

IEC 60068-2-6 (Sinusoidal vibration) test Fc	±0.38 mm (10-57 Hz), 5g (57-500 Hz) 10 frequency cycles per axis
IEC 60068-2-27 (Shock) Test Ea	30g, 11 ms
IEC 60068-2-11 (Corrosion) Test Ka	96 h in 5% salt mist
IEC 60068-2-78 (Humidity) Test Cab	48 h at 95% relative humidity, 40°C

Approvals (UL 489/CSA-C22.2 No. 5)

	Nominal current range	Rated voltage AC	Rated voltage DC	Interrupt capacity
TMC 81...	1 ... 32 A	277 V AC	60 V DC	10 kA
TMC 81...	35 ... 63A	120 V AC	60 V DC	10 kA
TMC 82...	1 ... 32 A	277 V AC (277/480Y, 240D)	125 V DC (two poles in series)	10 kA
TMC 82...	35 ... 63A	240 V AC (120/240S, 240D)	125 V DC (two poles in series)	10 kA
TMC 83...	1 ... 32 A	277 V AC (277/480Y, 240D)	125 V DC (two poles in series)	10 kA
TMC 83...	35 ... 63 A	240 V AC (120/240S, 240D)		10 kA

Approvals (UL 1077/CSA-C22.2 No. 235)

	Nominal current range	Rated voltage AC	Rated voltage DC	Short-circuit current rating (SCCR)
TMC 71...	1 ... 63 A	240 V AC	60 V DC	7.5 kA, U1
TMC 71...	1 ... 63A	277 V AC		5 kA, U1
TMC 72...	1 ... 63 A	277/480Y, 240D	125 V DC (two poles in series)	7.5 kA, U1
TMC 73...	1 ... 63 A	277/480Y, 240D		7.5 kA, U1

Approvals (IEC/EN 60947-2)

	Nominal current range	Rated voltage AC	Rated voltage DC	Rupture capacity
TMC 71...	-	240 V AC	80 V DC	7.5 kA AC/10 kA DC (Ics)
TMC 81...				10 kA (Icu)
TMC 72...	-	240/415 V AC	125 V DC (two poles in series)	7.5 kA AC/10 kA DC (Ics)
TMC 73...				10 kA DC (Icu)
TMC 82...				
TMC 83...				

3.1 Trip curve

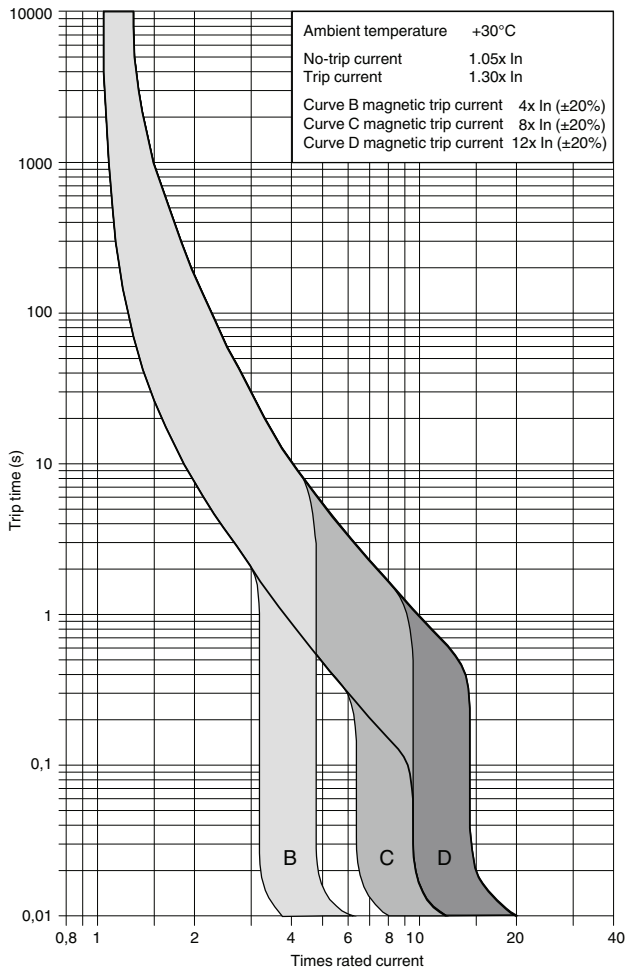

Figure 1 Trip curves



The current rating is reduced to 80% when mounted side by side.
 Magnetic tripping currents are increased by 30% on DC supplies (ambient temperature 30°C).

3.2 Current rating and voltage drop @ 25°C

TMC ... I _N (A)	Voltage drop (V)
1	1.50
2	0.80
3	0.60
4	0.60
5	0.20
6	0.20
7	0.20
8	0.15
10	0.15
12	0.15
13	0.10
15	0.10
16	0.10
20	0.08
25	0.08
30	0.07
32	0.07
35	0.07
40	0.07
50	0.06
60	0.06
63	0.06

3.3 Dimensions

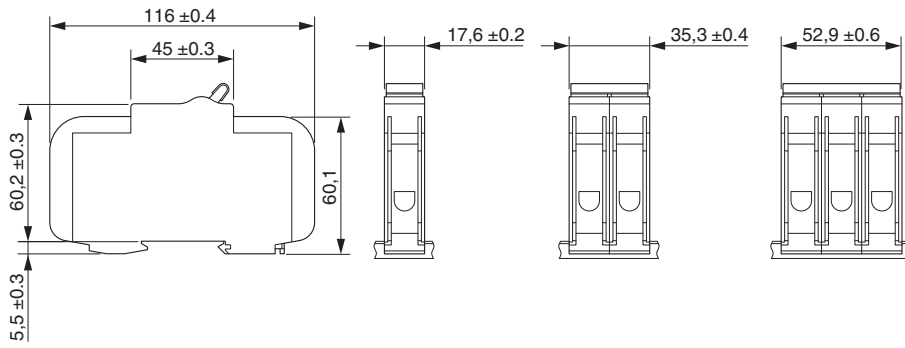

Figure 2 TMC 8... dimensions (mm)

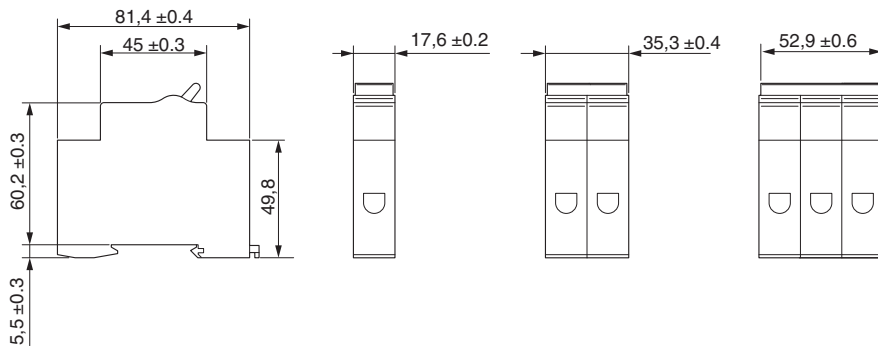

Figure 3 TMC 7... dimensions (mm)

3.4 Environmental influences

The following correction factors must be considered when selecting the appropriate nominal current rating for the circuit breaker.

I _N (A)	Maximum operating currents (A) depending on ambient temperature (°C)																					
	-35	-30	-25	-20	-15	-10	-5	0	+5	+10	+15	+20	+25	+30	+35	+40	+45	+50	+55	+60	+65	+70
1	1.27	1.25	1.23	1.21	1.19	1.17	1.15	1.13	1.10	1.08	1.06	1.05	1.02	1.00	0.97	0.94	0.91	0.89	0.86	0.83	0.80	0.77
2	2.54	2.50	2.46	2.42	2.38	2.34	2.30	2.26	2.20	2.16	2.12	2.10	2.04	2.00	1.94	1.88	1.82	1.78	1.72	1.66	1.60	1.54
3	3.89	3.83	3.76	3.70	3.64	3.57	3.50	3.44	3.37	3.30	3.22	3.14	3.06	3.00	2.92	2.84	2.76	2.67	2.58	2.49	2.38	2.27
4	5.08	5.00	4.92	4.84	4.76	4.68	4.60	4.52	4.40	4.32	4.24	4.20	4.08	4.00	3.88	3.76	3.64	3.56	3.44	3.32	3.20	3.08
5	6.68	6.56	6.44	6.32	6.19	6.07	5.94	5.81	5.68	5.54	5.40	5.25	5.12	5.00	4.82	4.66	4.50	4.34	4.17	3.99	3.81	3.62
6	7.70	7.58	7.46	7.34	7.21	7.09	6.96	6.83	6.70	6.56	6.42	6.27	6.14	6.00	5.84	5.68	5.52	5.36	5.19	5.01	4.83	4.64
7	8.78	8.66	8.54	8.42	8.29	8.17	8.04	7.91	7.78	7.64	7.50	7.35	7.22	7.00	6.92	6.76	6.60	6.44	6.27	6.09	5.91	5.72
8	9.80	9.68	9.56	9.44	9.31	9.19	9.06	8.93	8.80	8.66	8.52	8.37	8.24	8.00	7.94	7.78	7.62	7.46	7.29	7.11	6.93	6.74
10	13.89	13.62	13.35	13.07	12.81	12.53	12.23	11.93	11.63	11.33	11.01	10.67	10.34	10.00	9.63	9.24	8.85	8.45	8.01	7.55	7.06	6.55
12	15.91	15.64	15.37	15.09	14.83	14.55	14.25	13.95	13.65	13.35	13.03	12.69	12.36	12.00	11.65	11.26	10.60	10.47	10.03	9.57	9.08	8.57
13	16.92	16.65	16.38	16.10	15.84	15.56	15.26	14.96	14.66	14.36	14.04	13.70	13.37	13.00	12.66	12.27	11.61	11.48	11.04	10.58	10.09	9.58
15	19.77	19.42	19.07	18.74	18.39	18.04	17.69	17.32	16.95	16.57	16.19	15.79	15.39	15.00	14.54	14.10	13.65	13.19	12.70	12.20	11.69	11.64
16	20.78	20.43	20.08	19.75	19.40	19.05	18.70	18.33	17.96	17.58	17.20	16.80	16.40	16.00	15.55	15.11	14.66	14.20	13.71	13.21	12.70	12.75
20	25.67	25.28	24.88	24.47	24.06	23.64	23.22	22.78	22.34	21.89	21.43	20.96	20.47	20.00	19.47	18.95	18.42	17.87	17.30	16.71	16.10	15.47
25	32.21	31.72	31.22	30.70	30.18	29.65	29.10	28.55	27.98	27.41	26.82	26.22	25.61	25.00	24.33	23.67	23.00	22.28	21.56	20.80	20.02	19.21
30	39.00	38.42	37.78	37.13	36.47	35.80	35.11	34.43	33.71	32.99	32.26	31.50	30.73	30.00	29.13	28.30	27.44	26.56	25.65	24.71	23.74	22.73
32	41.04	40.46	39.82	39.17	38.51	37.84	37.15	36.47	35.75	35.03	34.30	33.54	32.77	32.00	31.17	30.34	29.48	28.69	27.69	26.75	25.78	24.77
35	44.08	43.50	42.86	42.21	41.55	40.88	40.19	39.51	38.79	38.07	37.34	36.58	35.81	35.00	34.21	33.38	32.52	31.64	30.73	29.79	28.82	27.81
40	51.63	50.86	50.04	49.21	48.37	47.51	46.63	45.74	44.83	43.90	42.95	41.98	40.99	40.00	38.93	37.85	36.75	35.61	34.43	33.21	31.95	30.63
50	64.92	63.97	62.92	61.86	60.77	59.67	58.54	57.40	56.23	55.05	53.81	52.56	51.23	50.00	47.82	46.24	44.81	43.33	41.81	40.23	38.58	35.77
60	80.45	79.03	77.61	76.16	74.69	73.19	71.67	70.11	68.51	66.88	65.21	63.50	61.75	60.00	57.08	55.16	53.18	51.13	49.00	46.78	44.47	40.47
63	83.48	82.06	80.64	79.19	77.72	76.22	74.70	73.14	71.54	69.91	68.24	66.53	64.78	63.00	60.11	58.19	56.21	54.16	52.03	49.81	47.50	43.05

4 Circuit breaker installation



WARNING:
Always remove power before installing or performing maintenance.

4.1 Mounting

- Hook the device over the top edge of the DIN rail and rotate it down until it snaps onto the bottom edge of the rail.
Ensure that the orange DIN rail latch securely locks the device to the rail.
- Repeat for any additional devices.
- Slide the devices together into the desired configuration.

4.2 Removal

- Slide the device away to gain sufficient clearance from the next device.
- Use a screwdriver to raise the latch and release the unit from the bottom edge of the DIN rail.
- Rotate the device and lift off of the top edge of the rail.

4.3 DC connection diagram

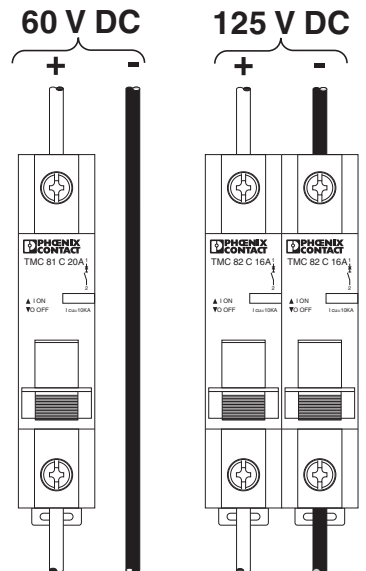

Figure 4 DC connection diagram

5 Accessories

Several accessories are available for use with the TMC 7/8... circuit breakers. The accessory modules are mounted on the left side (see Figure 10) of the circuit breaker. A variety of busbars are also available.

**NOTE:**

Accessory modules must be installed in the proper order: shunt trip, alarm contact, and then the auxiliary contact.

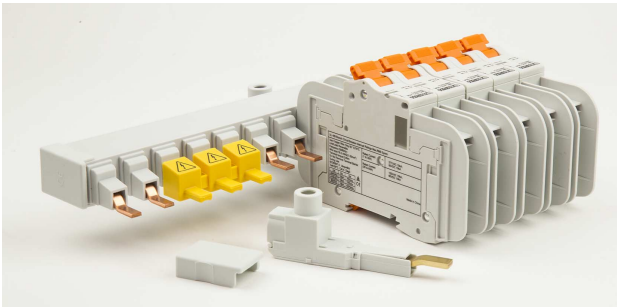

Figure 5 Busbar and other accessories

6 Ordering data for accessories

Accessories

Description	Type	Order No.	Pcs./Pkt.
Auxiliary contact, one NO and one NC switch	TMC 7/8 AUX	2908219	1
Alarm contact, one NO and one NC	TMC 7/8 ALARM	2908220	1
Shunt trip, 12 V DC, one NO and one NC	TMC 7/8 12VDC SHNT	2908221	1
Shunt trip, 24 V DC, one NO and one NC	TMC 7/8 24VDC SHNT	2908222	1
Shunt trip, 48 V DC, one NO and one NC	TMC 7/8 48VDC SHNT	2908224	1
Shunt trip, 125 V DC, one NO and one NC	TMC 7/8 125VDC SHNT	2908225	1
Shunt trip, 120 V AC, one NO and one NC	TMC 7/8 120VAC SHNT	2908226	1
Shunt trip, 240 V AC, one NO and one NC	TMC 7/8 240VAC SHNT	2908227	1
Shunt trip, 277 V AC, one NO and one NC	TMC 7/8 277VAC SHNT	2908228	1
Busbar, cut to length, for TMC 7... 1-pole applications, up to 57 positions, UL Listed	TMC 7 B1 80 57 C	1022238	1
Busbar, cut to length, for TMC 7... 1-pole plus auxiliary applications, up to 37 positions, UL Listed	TMC 7 B1 80 37 CA	1022237	1
Busbar, cut to length, for TMC 7... 2-pole applications, up to 56 positions, UL Listed	TMC 7 B2 80 56 C	1022236	1
Busbar, cut to length, for TMC 7... 2-pole plus auxiliary applications, up to 46 positions, UL Listed	TMC 7 B2 80 46 CA	1022235	1
Busbar, cut to length, for TMC 7... 3-pole applications, up to 57 positions, UL Listed	TMC 7 B3 80 57 C	1022234	1
Busbar, cut to length, for TMC 7... 3-pole plus auxiliary applications, up to 48 positions, UL Listed	TMC 7 B3 80 48 CA	1025400	1
Busbar terminal, 1-pole incoming connections, for TMC 7...	TMC 7 B1 TERM	1022233	1
Busbar terminal, 2- and 3-pole incoming connections, for TMC 7...	TMC 7 B2/3 TERM	1022232	1
Busbar, end cap, 1-pole, protects open busbar positions, for TMC 7...	TMC 7 B1 END CAP	1022231	1
Busbar, end cap, 2- and 3-pole, protects open busbar positions, for TMC 7...	TMC 7 B2/3 END CAP	1022229	1
Busbar, bus cap, protects three open busbar positions, for TMC 7...	TMC 7 B BUS CAP	1022224	1
Busbar, cut to length, for TMC 8... 1-pole applications, up to 57 positions, UL Listed	TMC 8 B1 80 57 C	2907991	1
Busbar, cut to length, for TMC 8... 1-pole plus auxiliary applications, up to 37 positions, UL Listed	TMC 8 B1 80 37 CA	2907992	1
Busbar, cut to length, for TMC 8... 2-pole applications, up to 56 positions, UL Listed	TMC 8 B2 80 56 C	2907993	1
Busbar, cut to length, for TMC 8... 2-pole plus auxiliary applications, up to 46 positions, UL Listed	TMC 8 B2 80 46 CA	2907995	1
Busbar, cut to length, for TMC 8... 3-pole applications, up to 57 positions, UL Listed	TMC 8 B3 80 57 C	2907996	1
Busbar, cut to length, for TMC 8... 3-pole plus auxiliary applications, up to 48 positions, UL Listed	TMC 8 B3 80 48 CA	2907997	1
Busbar terminal, incoming connections, TMC 8...	TMC 8 B TERM PIN	2907998	1
Busbar, end cap, protects open busbar positions, TMC 8...	TMC 8 B END CAP	2907999	1
Busbar, bus cap, protects three open busbar positions, TMC 8...	TMC 8 B BUS CAP	2908000	1

7 Technical data for accessories

7.1 Technical data for TMC 7/8 AUX and TMC 7/8 ALARM accessories

General data (TMC 7/8 AUX and TMC 7/8 ALARM)

Ambient temperature, operating	-35 ... 70°C (-31 ... 158°F)
Degree of protection	IP20
Weight	29 g (approximate)
Width	9 mm
Installation	Left side of circuit breaker
Conductor cross section	1 ... 35 mm ² /18 ... 2 AWG
Connection type	Screw-clamp terminals
Conductor tightening torque, maximum	1 Nm (8.9 lb _f -in.)
Service life, mechanical	20,000 cycles

Electrical data (TMC 7/8 AUX and TMC 7/8 ALARM)

Nominal voltage, U _N (IEC/EN 60947-5-1)	12 V DC ... 220 V DC 12 V AC ... 277 V AC
Rated current (IEC/EN 60947-5-1)	
240 V AC	6 A
24 V DC	6 A
48 V DC	2 A
130 V DC	1 A
Rated current (UL 489)	
12 ... 240 V AC	6 A
277 V AC	3 A
12 ... 24 V DC	6 A
48 V DC	3A
110 ... 220 V DC	1.5 A

General data (TMC 7/8...SHNT)

Ambient temperature, operating	-35 ... 70°C (-31 ... 158°F)
Degree of protection	IP20
Weight	60 g (approximate)
Width	18 mm
Installation	Left side of circuit breaker
Conductor cross section	1 ... 35 mm ² /18 ... 2 AWG
Connection type	Screw-clamp terminals
Conductor tightening torque, maximum	1 Nm (8.9 lb _f -in.)
Service life, mechanical	20,000 cycles

Electrical data (TMC 7/8...SHNT)

Nominal voltage, U_N	12 V DC ... 125 V DC 120 V AC ... 277 V AC
Trip voltage	
277 V AC	160 V AC
240 V AC	160 V AC
120 V AC	80 V AC
125 V DC	125 V DC
48 V DC	24 V DC
24 V DC	16 V DC
12 V DC	8 V DC
Power consumption/minimum response power	
277 V AC	240 W/35 W
240 V AC	200 W/35 W
120 V AC	200 W/35 W
125 V DC	200 W/30 VA
48 V DC	200 W/30 VA
24 V DC	200 W/30 VA
12 V DC	200 W/30 VA
Trip time	<10 ms

7.2 Technical data for busbars and termination pins**General data (TMC 8 B...)**

Ambient temperature, operating	-35 ... 70°C (-31 ... 158°F)
Degree of protection	IP20
Step size	17.8 mm
Busbar cross section	18 mm ²

Electrical data (TMC 8 B...)

Maximum voltage	
Single phase	1000 V AC/DC
2- and 3-phase	600 V AC/DC
Rated current at 35°C (UL 489)	
Power supply at the end	80 A
Power supply in the middle ¹	160 A
SCCR I_{CC}	10 kA

¹ Two 115 A TMC 8 B TERM PIN terminals required per phase

Electrical data (TMC 8 B TERM PIN)

Maximum voltage	1000 V AC/DC
Maximum current	115 A
Connection type	Screw clamp
Required conductor material	Cu
Conductor cross section	2.5 ... 35 mm ² /14 ... 2 AWG
Tightening torque, maximum	5.5 Nm (50 lb _f -in.)

General data (TMC 7 B...)

Ambient temperature, operating	-35 ... 70°C (-31 ... 158°F)
Degree of protection	IP20
Step size	17.8 mm
Busbar cross section	18 mm ²

Electrical data (TMC 7 B...)

Maximum voltage	
Single phase	600 V AC/1000 V DC
2- and 3-phase	600 V AC/DC
Rated current at 35°C (UL 508)	
Power supply at the end	80 A
Power supply in the middle ¹	160 A
SCCR I _{CC}	10 kA

¹ Two 115 A TMC 7 B TERM PIN terminals required per phase

Electrical data (TMC 7 B TERM PIN)

Maximum voltage	1000 V AC/DC
Maximum current	115 A
Connection type	Screw clamp
Required conductor material	Cu
Conductor cross section	6 ... 50 mm ² /10 ... 1/0 AWG
Tightening torque, maximum	5.5 Nm (50 lb _f -in.)

8 Accessory descriptions

8.1 Auxiliary contact (TMC 7/8 AUX)

The TMC 7/8 AUX is an add-on module, mounted on the left side of the TMC 7/8... when viewed from the front. The TMC 7/8 AUX acts as a signal contact and changes state with the actuation of TMC 7/8....

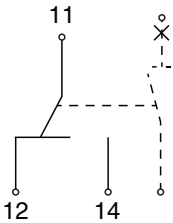

Figure 6 TMC 7/8 AUX schematic shown in off position

i After the TMC 7/8 AUX module is attached to the TMC 7/8... circuit breaker, terminals 11 and 14 are connected when the circuit breaker is in the “on” condition. Terminals 11 and 12 are connected when the circuit breaker is in the “off” condition.

8.2 Alarm contact (TMC 7/8 ALARM)

The TMC 7/8 ALARM is an add-on module mounted on the left side of the TMC 7/8... when viewed from the front. Once set in the on position, the TMC 7/8 ALARM acts as a signal contact and changes state when an electrical event occurs, such as an overload or short circuit, to the TMC 7/8....

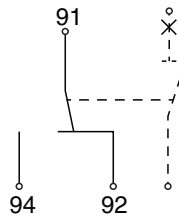

Figure 7 TMC 7/8 ALARM schematic shown in on position

i After the TMC 7/8 ALARM module is attached to the TMC 7/8... circuit breaker:

- Terminals 91 and 92 are connected when the circuit breaker is in the “on” condition.
- Terminals 91 and 94 are connected when the circuit breaker is tripped electronically.
- Terminals 91 and 92 are connected when the circuit breaker is tripped manually.
- At the same time, terminals 91 and 94 do not make contact.

8.3 Shunt trip (TMC 7/8...SHNT)

The TMC 7/8...SHNT is an add-on module, mounted on the left side of the TMC 7/8... when viewed from the front. The TMC 7/8... circuit breaker can be remotely tripped by applying the rated voltage pulse across terminals C1 and C2.

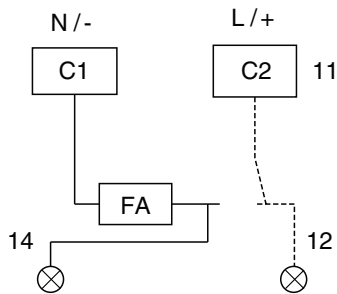

Figure 8 TMC 7/8 AUX schematic (shown in "off" position)

9 TMC 7/8 AUX / TMC 7/8 ALARM / TMC 7/8...SHNT installation



Installation is the same for all types of accessories. Images show TMC 8... products.

Circuit breaker preparation (Figure 9)

1. Remove the end pieces (1) from the TMC 7/8... by sliding it up and away from the center section (2) of the circuit breaker.

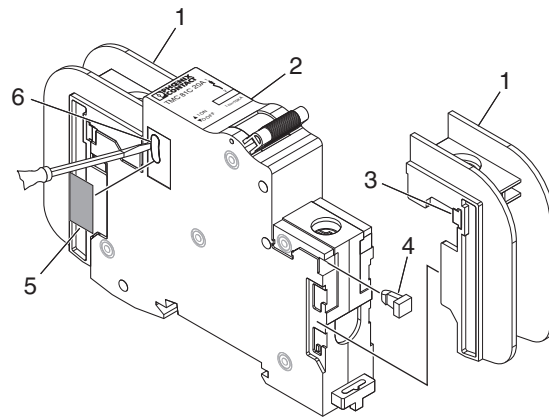

Figure 9 Removing tabs for accessory installation

2. Use a small pliers and break off the tabs (3) on each end piece.
3. Use a screwdriver to remove the two wedges (4) on the TMC 7/8....
4. Remove the tape seal (5) covering the electrical interface.
5. Use a screwdriver to break off the cover (6) over the latch insert point.
6. Do not install the end pieces (1) at this time.

Accessory installation (Figure 10)

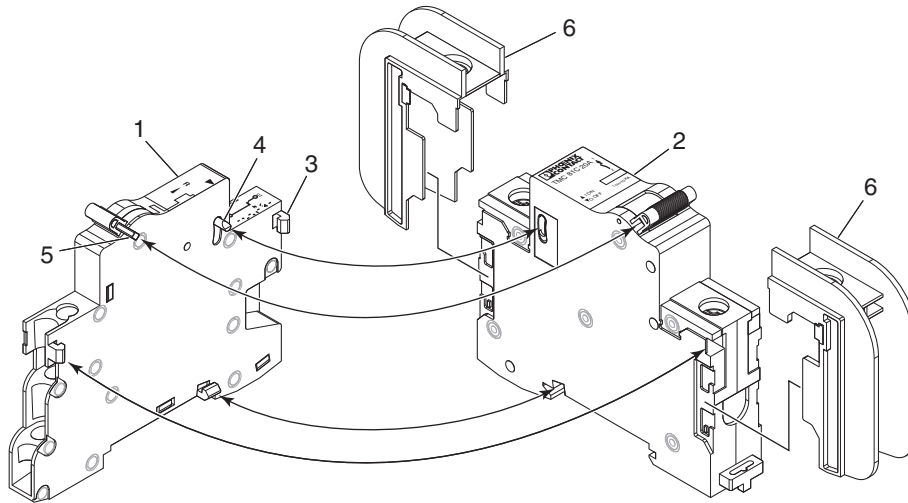

Figure 10 Accessory installation

1. Place the accessory (1) in position on the left side of the TMC 7/8... (2) making sure to align the locking clips (3), latch (4), and switch handle (5) with the TMC 7/8..., and then snap the accessory into place.
2. Reinstall the end pieces (6) previously removed (TMC 8... only).



NOTE:

The end pieces must be installed for the TMC 8... to maintain UL 489 compliance.

3. Install on the mounting rail, and connect wires, as required.

9.1 Busbars and related accessories

Busbars can be purchased for 1-, 2-, and 3-pole circuit breakers.



Busbars, terminals, and caps are specific to TMC 7... and TMC 8.... They are not interchangeable.
 Busbars with a descriptor of TMC...CA accommodate circuit breakers with TMC 7/8 AUX and TMC 7/8 ALARM installed.

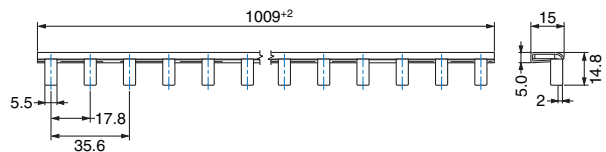

Figure 11 TMC 7...B1...C dimensions (mm)

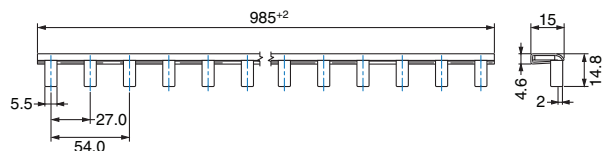

Figure 12 TMC 7...B1...CA dimensions (mm)

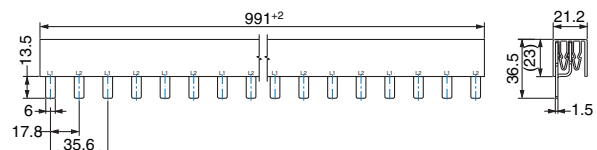

Figure 13 TMC 7...B2...C dimensions (mm)

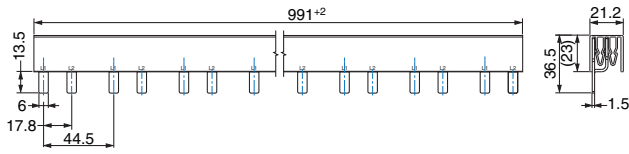

Figure 14 TMC 7...B2...CA dimensions (mm)

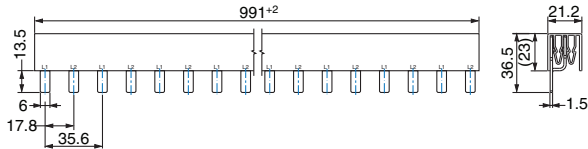

Figure 15 TMC 7...B3...C dimensions (mm)

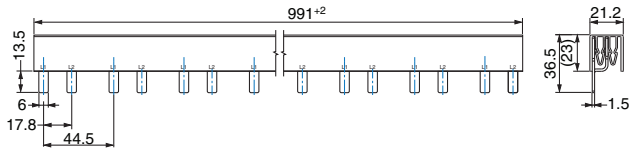

Figure 16 TMC 7...B3...CA dimensions (mm)

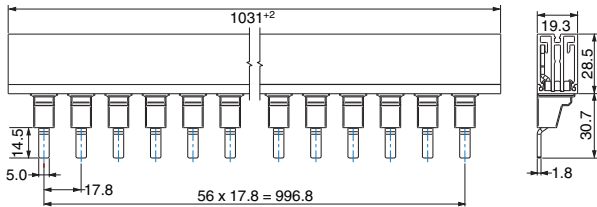

Figure 17 TMC 8...B1...C dimensions (mm)

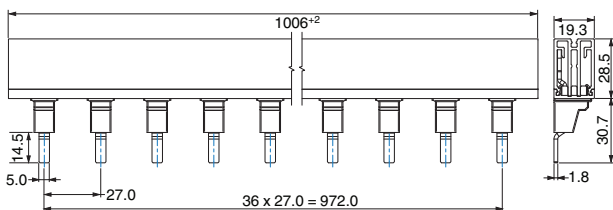

Figure 18 TMC 8...B1...CA dimensions (mm)

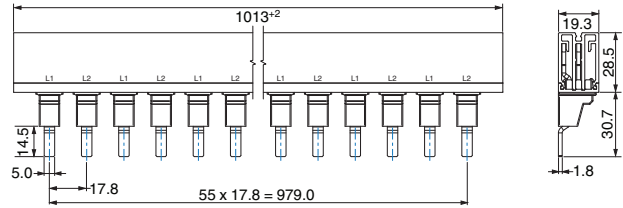

Figure 19 TMC 8...B2...C dimensions (mm)

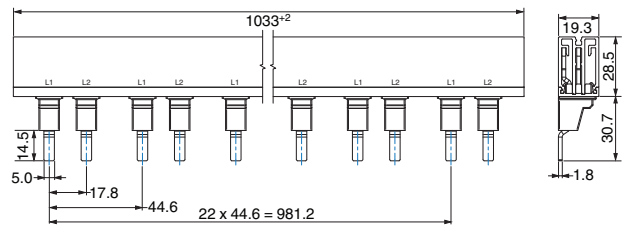

Figure 20 TMC 8...B2...CA dimensions (mm)

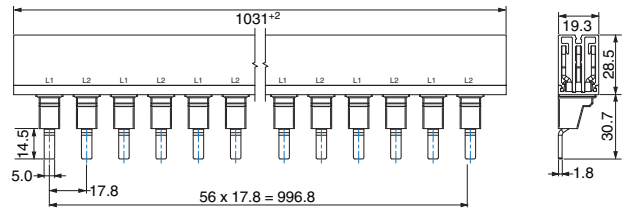

Figure 21 TMC 8...B3...C dimensions (mm)

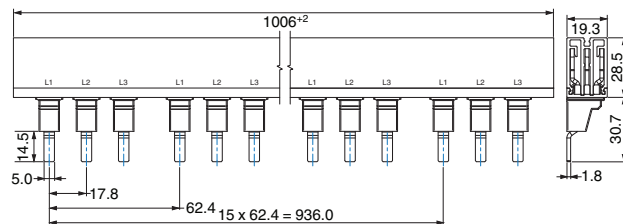

Figure 22 TMC 8...B3...CA dimensions (mm)

Busbars come in lengths of approximately 1000 mm and can be cut to the desired length. The TMC...B TERM PIN permits connection of wires to the busbar terminals; bus caps are available for protection and touch-free safety.

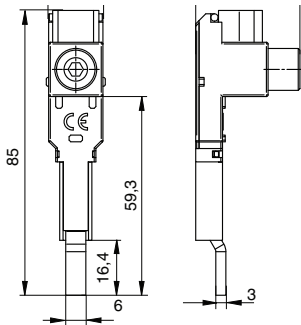

Figure 23 TMC 8 B TERM PIN dimensions (mm)

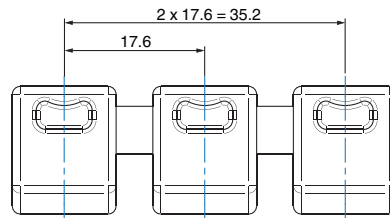
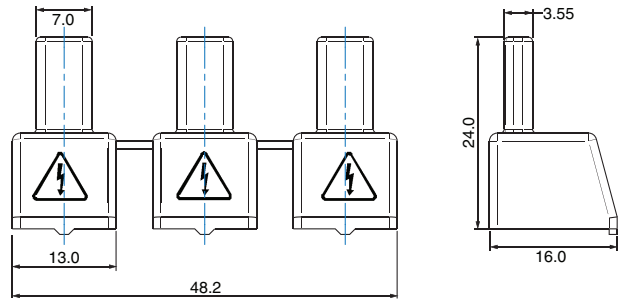

Figure 26 TMC 8 B BUS CAP dimensions

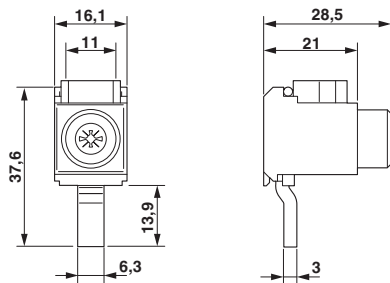

Figure 24 TMC 7 B TERM PIN dimensions

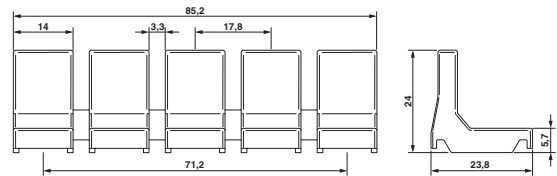

Figure 27 TMC 7B BUS CAP dimensions

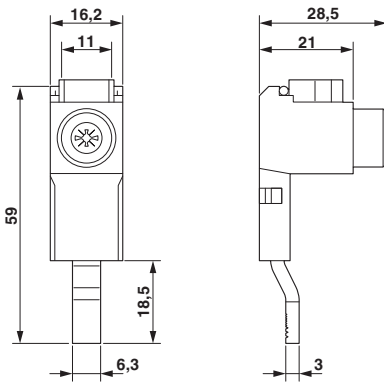

Figure 25 TMC 7 B2/3 TERM PIN dimensions

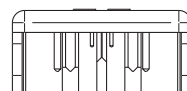
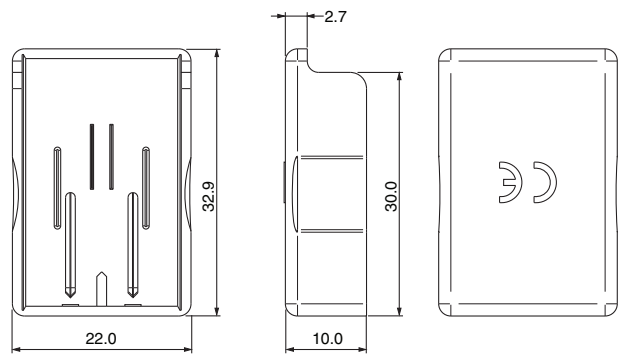

Figure 28 TMC 8 B END CAP dimensions

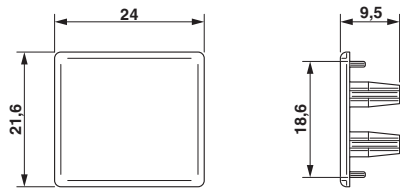

Figure 29 TMC 8 B2/3 END CAP dimensions

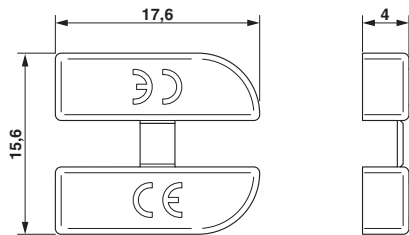

Figure 30 TMC 7 B1 END CAP dimensions

9.1.1 Busbar installation

The busbars must be cut to the desired length of the number of circuit breakers.



WARNING:

Always remove power before installing or performing maintenance.
Keep metal chips and filings clear of electrical contact points.

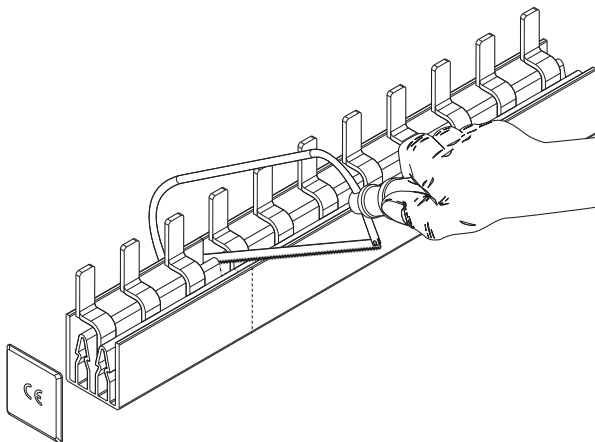

Figure 31 Busbar installation

1. Use a hacksaw or similar device to cut the busbar to the desired length. Match the number of circuit breakers plus the number of TMC ... B TERM PIN terminals to be installed.



For ease of cutting, the metal portion of the busbar may be removed from the insulation material, but it must be reinstalled correctly to maintain agency certification.

2. Use a wire brush or file to remove any burrs and sharp edges from the cut end of the bus bar. Remove any remaining particles using compressed air or a bristle brush.



NOTE:

Endcaps are recommended for use with all busbar installations.

3. Install end caps on both ends of the busbar.
4. Install the TMC ... B TERM PIN terminals.
5. Install busbar assembly and secure. Tighten to 5.5 Nm.

单击下面可查看定价，库存，交付和生命周期等信息

[>>Phoenix Contact\(菲尼克斯\)](#)