

Electronic housing - UEG 30/1 - 2790871

Please be informed that the data shown in this PDF Document is generated from our Online Catalog. Please find the complete data in the user's documentation. Our General Terms of Use for Downloads are valid (<http://download.phoenixcontact.com>)



Electronic housing, for PCB insertion, fully equipped with 4 screw or tab connections per side

Product Features

- ✓ Universal P1-UEG... PCBs are available for laboratory samples and small series
- ✓ Cost-effective series production, since the base element and the assembled PCB are soldered by machine
- ✓ Efficient assembly thanks to overlapping housing parts
- ✓ Can be snapped onto standard NS 35/7,5 and NS 35/15 DIN rails
- ✓ Up to 16 connections on two levels
- ✓ Installation of one or two PCBs in the housing



Key commercial data

Packing unit	1 PCE
GTIN	 4 017918 072360
Custom tariff number	85369010
Country of origin	GERMANY

Technical data

General

Housing type	Complete housing
Housing material	Polyamide (PA 6.6)
Color	green

Dimensions

Length	79.5 mm
Constructional height	70 mm
Width	30 mm

Electronic housing - UEG 30/1 - 2790871

Technical data

Dimensions

Pitch	5 mm
-------	------

Technical data

Ambient temperature (operation)	-40 °C ... 105 °C
Inflammability class according to UL 94	V0
Power dissipation at 20°C in the horizontal mounting position	4 W 7.2 W
Number of positions	8

Connection data

Conductor cross section solid min.	0.2 mm ²
Conductor cross section solid max.	4 mm ²
Conductor cross section stranded min.	0.2 mm ²
Conductor cross section stranded max.	2.5 mm ²
Conductor cross section AWG/kcmil min.	24
Conductor cross section AWG/kcmil max	12
Stripping length	8 mm

Classifications

eCl@ss

eCl@ss 4.0	27180401
eCl@ss 4.1	27180401
eCl@ss 5.0	27180506
eCl@ss 5.1	27180506
eCl@ss 6.0	27180802
eCl@ss 7.0	27182702

ETIM

ETIM 2.0	EC001031
ETIM 3.0	EC001031
ETIM 4.0	EC001031
ETIM 5.0	EC001031

UNSPSC

UNSPSC 6.01	31261501
UNSPSC 7.0901	31261501
UNSPSC 11	31261501
UNSPSC 12.01	31261501
UNSPSC 13.2	31261501

Electronic housing - UEG 30/1 - 2790871

Approvals

Approvals

Approvals

GOST / GOST

Ex Approvals

Approvals submitted

Approval details

GOST 

GOST 

Accessories

Accessories

Bridges

Wire bridge - DB 50- 90 GY - 2820929

Wire bridge, Color: gray



Drawings

Electronic housing - UEG 30/1 - 2790871

Explosion drawing

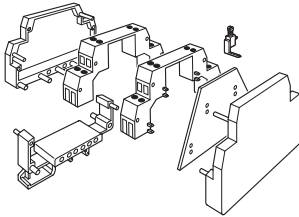

Dimensioned drawing

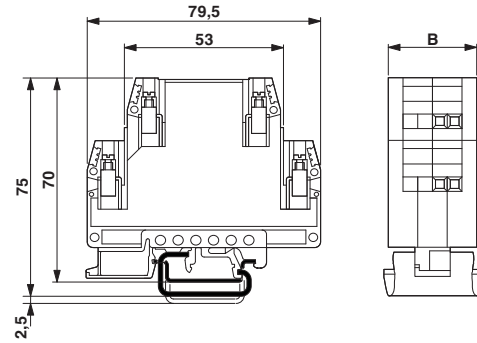

Dimensioned drawing

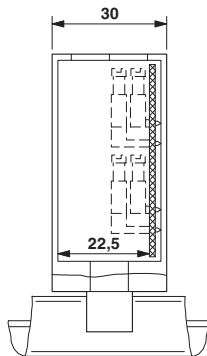

Dimensioned drawing

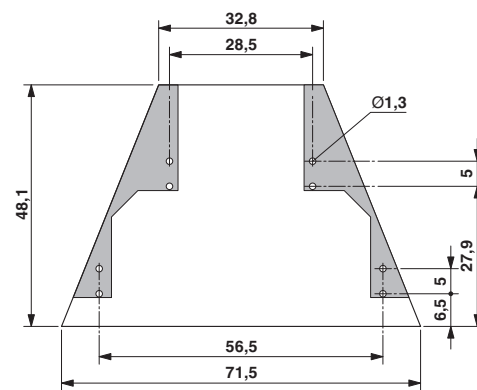

UEG 30/1, enlarged internal area, with 1 PCB, up to max. 8 positions

Schematic diagram

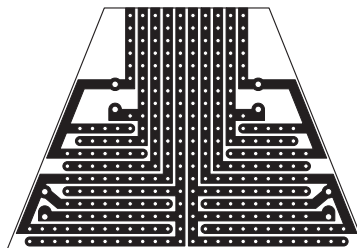

单击下面可查看定价，库存，交付和生命周期等信息

[>>Phoenix Contact\(菲尼克斯\)](#)