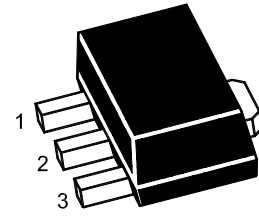

**Features**

- For AF driver and output stages
- High collector current
- Low collector-emitter saturation voltage

**SOT-89**

1.Base 2.Collector 3.Emitter

**Absolute Maximum Ratings** ( $T_a=25^{\circ}\text{C}$  unless otherwise specified)

Parameter	Symbol	Value	Units
Collector Base Voltage	$V_{CBO}$	-100	V
Collector Emitter Voltage	$V_{CEO}$	-80	V
Emitter Base Voltage	$V_{EBO}$	-5	V
Collector Current	$I_C$	-1	A
Peak Collector Current	$I_{CM}$	-1.5	A
Total Power Dissipation	$P_{tot}$	0.5 <sup>(1)</sup> 1.3 <sup>(2)</sup>	W
Junction Temperature	$T_J$	150	$^{\circ}\text{C}$
Storage Temperature Range	$T_{stg}$	- 65 to + 150	$^{\circ}\text{C}$

Note :1.Device mounted on an FR4 Printed-Circuit Board(PCB), single-sided copper, tin-plated and standard footprint.

2. Device mounted on an FR4 PCB, single-sided copper, tin-plated, mounting pad for collector 6 cm<sup>2</sup>

**Electrical Characteristics** ( $T_a=25^{\circ}\text{C}$  unless otherwise specified)

Parameter	Symbol	Min.	Typ.	Max.	Units
DC Current Gain					
at $V_{CE} = -2\text{ V}$ , $I_C = -5\text{ mA}$	$h_{FE}$	40	-	-	-
at $V_{CE} = -2\text{ V}$ , $I_C = -150\text{ mA}$	BCX53SQ-10 $h_{FE}$	63	-	160	-
	BCX53SQ-16 $h_{FE}$	100	-	250	-
at $V_{CE} = -2\text{ V}$ , $I_C = -500\text{ mA}$	$h_{FE}$	25	-	-	-
Collector Base Cutoff Current at $V_{CB} = -30\text{ V}$	$-I_{CBO}$	-	-	100	nA
Emitter Base Cutoff Current at $V_{EB} = -5\text{ V}$	$-I_{EBO}$	-	-	100	nA
Collector Base Breakdown Voltage at $I_C = -100\text{ }\mu\text{A}$	$-V_{(BR)CBO}$	100	-	-	V
Collector Emitter Breakdown Voltage at $I_C = -1\text{ mA}$	$-V_{(BR)CEO}$	80	-	-	V
Emitter Base Breakdown Voltage at $I_E = -100\text{ }\mu\text{A}$	$-V_{(BR)EBO}$	5	-	-	V
Collector Emitter Saturation Voltage at $I_C = -500\text{ mA}$ , $I_B = -50\text{ mA}$	$-V_{CE(sat)}$	-	-	0.5	V
Base Emitter Voltage at $V_{CE} = -2\text{ V}$ , $I_C = -500\text{ mA}$	$-V_{BE}$	-	-	1	V
Transition Frequency at $V_{CE} = -5\text{ V}$ , $I_C = -50\text{ mA}$ , $f = 100\text{ MHz}$	$f_T$	-	145	-	MHz
Collector Capacitance at $V_{CB} = -15\text{ V}$ , $f = 1\text{ MHz}$	$C_c$	-	15	-	pF



Typical Characteristic Curves

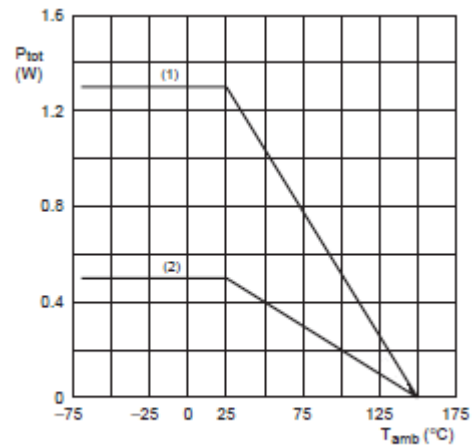
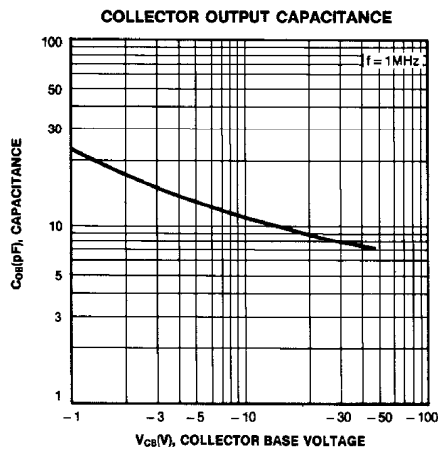
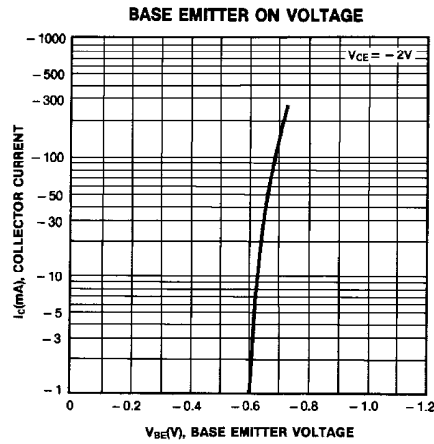
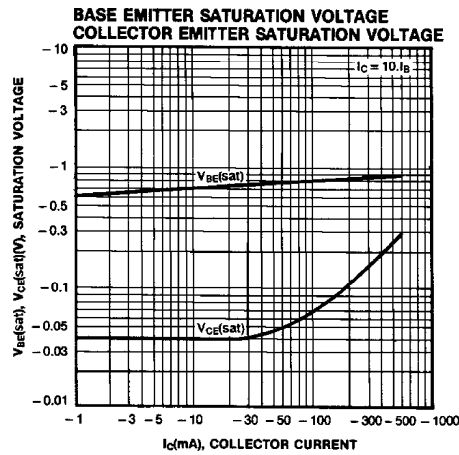
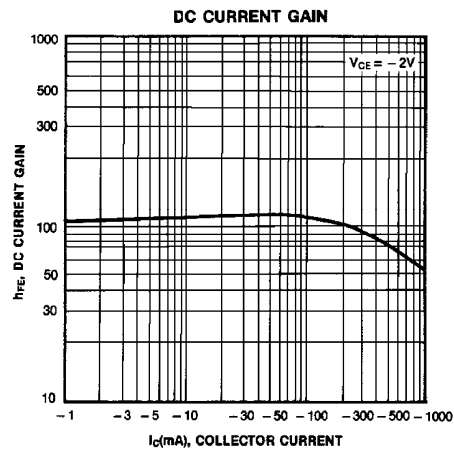
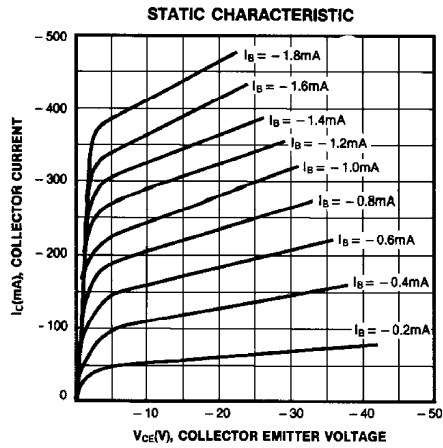

- (1) FR4 PCB, mounting pad for collector 6 cm<sup>2</sup>
- (2) FR4 PCB, standard footprint

Power derating curves

**Package Outline**

SOT-89

Dimensions in mm

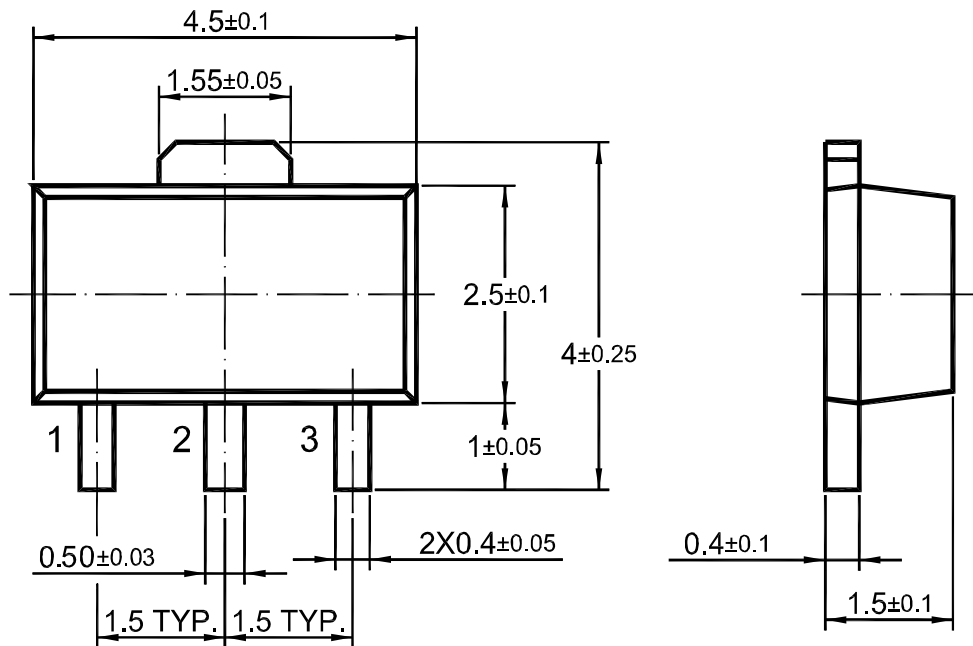
**Ordering information**

Device	Package	Shipping
BCX53SQ	SOT-89	1000PCS/Reel&Tape

单击下面可查看定价，库存，交付和生命周期等信息

[>>PJSEMI\(平晶微\)](#)