



PJM123NSA

N- Enhancement Mode Field Effect Transistor

Features

- ◆ Surface Mount Package
- ◆ Low $R_{DS(ON)}$
- ◆ ESD protected(HBM) up to 2KV

Applications

- ◆ Switching Application
- ◆ Small Servo Motor Controls

SOT-23

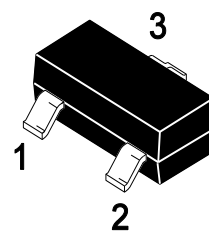

1. Gate 2.Source 3.Drain
Marking: B123

Schematic diagram

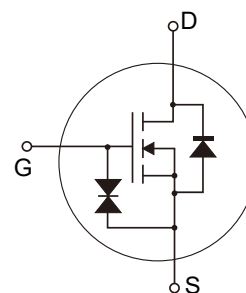

Absolute Maximum Ratings

($T_C=25^{\circ}C$, unless otherwise noted)

Parameter	Symbol	Value	Unit
Drain-Source Voltage	V_{DS}	100	V
Gate-Source Voltage	V_{GS}	± 20	V
Continuous Drain Current	I_D	0.17	A
Pulsed Drain Current $t_p=10\mu s$	I_{DM}	0.68	
Power Dissipation	P_D	0.9	W
Junction Temperature	T_J	150	$^{\circ}C$
Storage Temperature Range	T_{STG}	-55 to 150	$^{\circ}C$
Thermal Characteristics			
Parameter	Symbol	Typ.	Units
Maximum Junction-to-Ambient ^{Note1}	$R_{\theta JA}$	139	$^{\circ}C/W$



Electrical Characteristics

(T_A=25°C, unless otherwise noted)

Parameter	Symbol	Test Conditions	Min	Typ	Max	Unit
Static Parameters						
Drain-Source Breakdown Voltage	V _{(BR)DSS}	V _{GS} = 0V, I _D = 250μA	100	-	-	V
Gate Leakage Current	I _{GSS}	V _{DS} = 0V, V _{GS} = ±20V	-	-	±10	μA
Zero Gate Voltage Drain Current	I _{DSS}	V _{DS} = 100V, V _{GS} = 0V	-	-	1	μA
Gate Threshold Voltage ^{Note2}	V _{GS(th)}	V _{DS} = V _{GS} , I _D = 250μA	1	-	3	V
Drain-Source On-Resistance ^{Note2}	R _{DS(ON)}	V _{GS} = 10V, I _D = 0.17A	-	3.5	6	Ω
		V _{GS} = 4.5V, I _D = 0.17A	-	3.8	10	Ω
Forward transconductance ^{Note2}	g _{fs}	V _{DS} = 10V, I _D = 0.17A	80	-	-	mS
Dynamic Parameters						
Input Capacitance	C _{iss}	V _{DS} = 25V, V _{GS} = 0V, f = 1MHz	-	29	60	pF
Output Capacitance	C _{oss}		-	10	15	
Reverse Transfer Capacitance	C _{rss}		-	2	6	
Switching Parameters						
Turn-On Delay Time	t _{d(on)}	V _{DD} =30V, V _{GS} =10V R _{GEN} =50Ω, I _D =0.28A	-	-	8	ns
Turn-On Rise Time	t _r		-	-	8	
Turn-Off Delay Time	t _{d(off)}		-	-	13	
Turn-Off Fall Time	t _f		-	-	16	
Total Gate Charge	Q _g	V _{DS} =10V, V _{GS} =10V, I _D =0.22A	-	1.4	2	nC
Gate-Source Charge	Q _{gs}		-	0.15	0.25	
Gate-Drain Charge	Q _{gd}		-	0.2	0.4	
Drain-source Diode Parameters						
Source-Drain Diode Current	I _s		-	-	0.17	A
Forward Diode Voltage	V _{SD}	V _{GS} = 0V, I _s = 0.34A	-	-	1.3	V

Notes:1. Surface mounted on FR4 board using the minimum recommended pad size.

2. Pulse Test: Pulse width=300μs, duty cycle ≤2%.



PJM123NSA

N- Enhancement Mode Field Effect Transistor

Ratings And Characteristic Curves

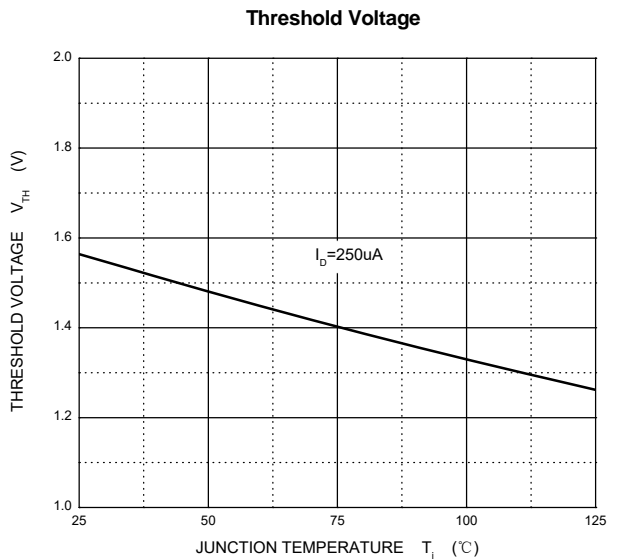
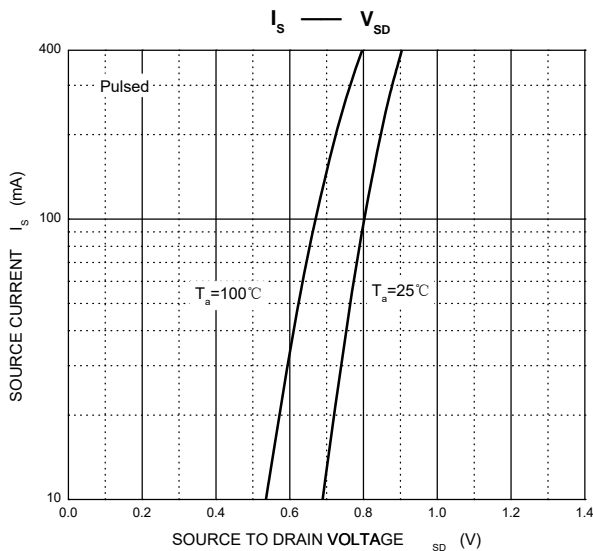
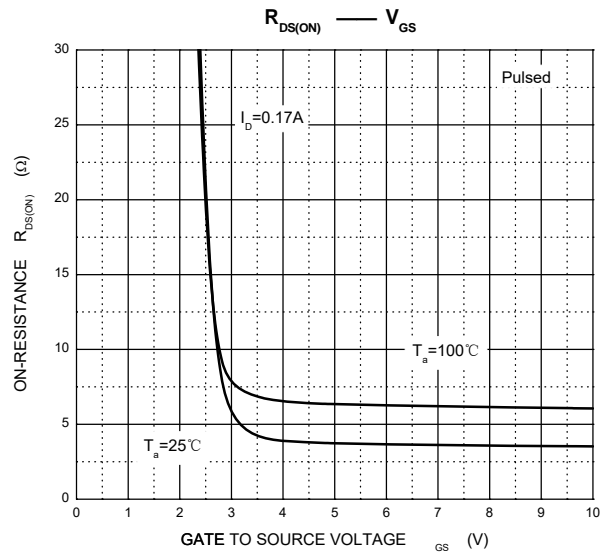
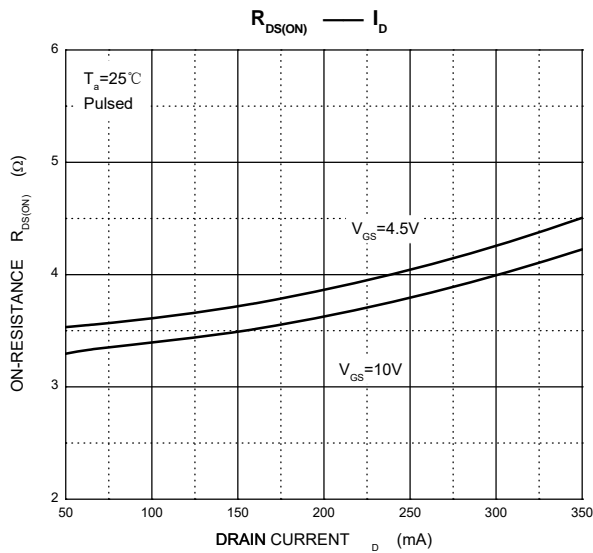
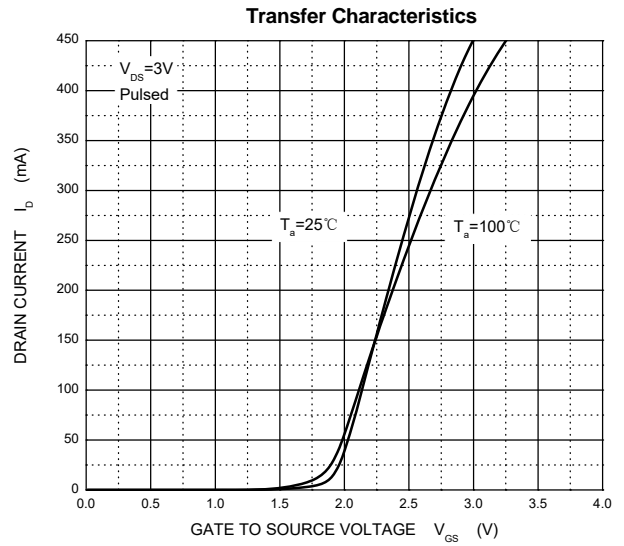
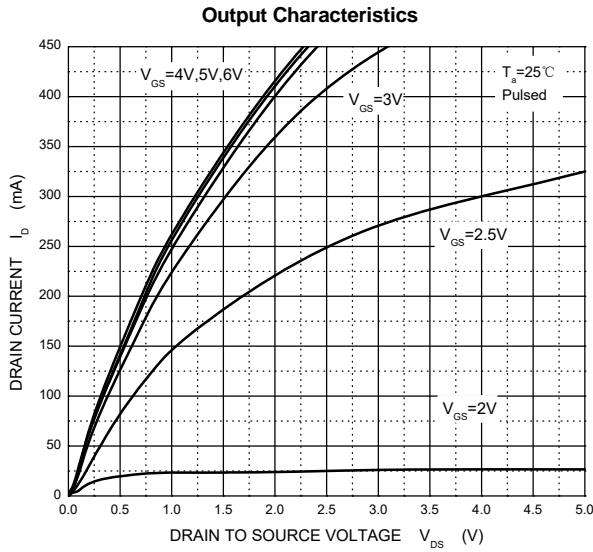



PJM123NSA

N- Enhancement Mode Field Effect Transistor

Package Outline

SOT-23 (TO-236)

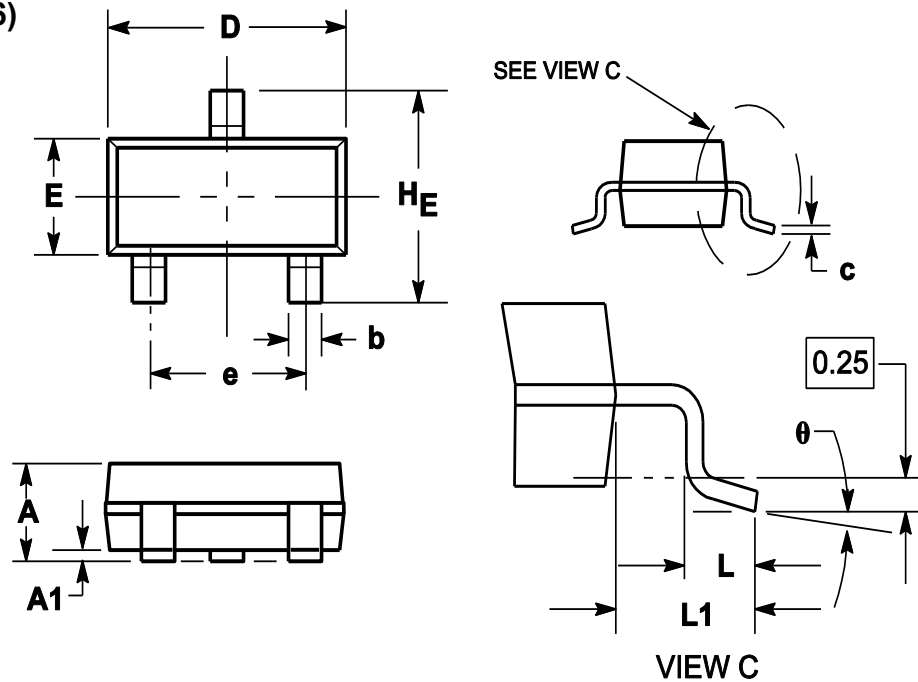

Symbol	Dimensions in millimeter		
	Min.	Typ.	Max.
A	0.900	1.025	1.150
A1	0.000	0.050	0.100
b	0.300	0.400	0.500
c	0.080	0.115	0.150
D	2.800	2.900	3.000
E	1.200	1.300	1.400
HE	2.250	2.400	2.550
e	1.800	1.900	2.000
L1	0.550REF		
L	0.300		0.500
θ	0°		8°

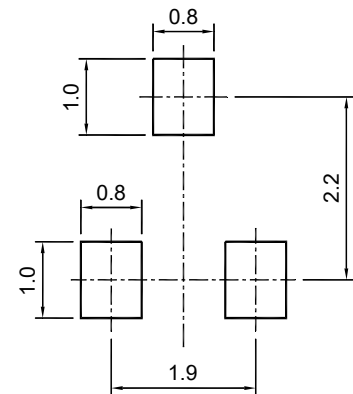

SOT-23 (TO-236)

Recommended soldering pad

Ordering Information

Device	Package	Shipping
PJM123NSA	SOT-23	3000/Reel&Tape(7inch)



Conditions of Soldering and Storage

◆ Recommended condition of reflow soldering

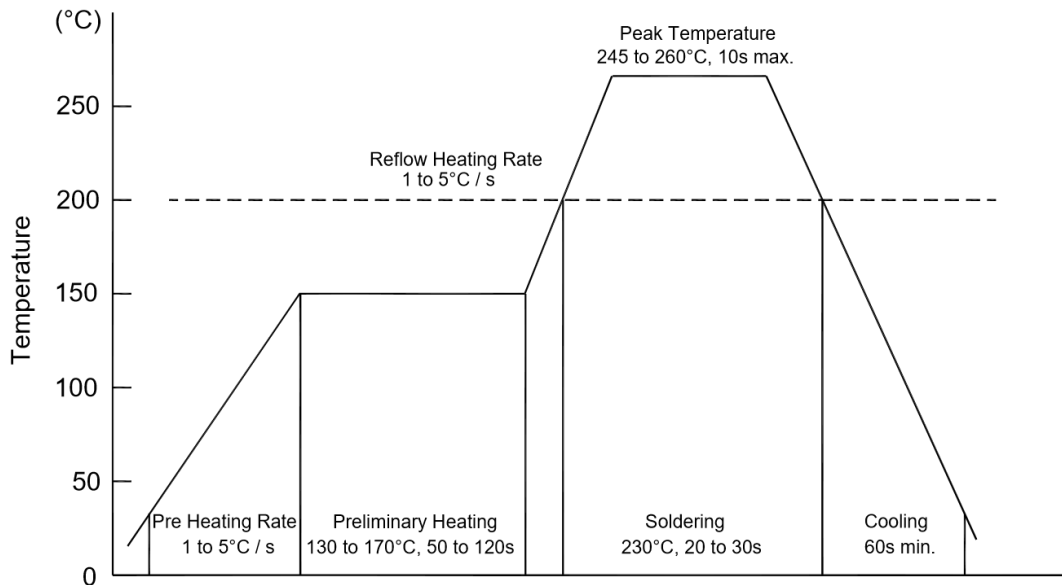

Recommended peak temperature is over 245 °C. If peak temperature is below 245 °C, you may adjust the following parameters:

- Time length of peak temperature (longer)
- Time length of soldering (longer)
- Thickness of solder paste (thicker)

◆ Conditions of hand soldering

- Temperature: 370 °C
- Time: 3s max.
- Times: one time

◆ Storage conditions

- **Temperature**
5 to 40 °C
- **Humidity**
30 to 80% RH
- **Recommended period**
One year after manufacturing



PJM123NSA

N- Enhancement Mode Field Effect Transistor

Package Specifications

◆ The method of packaging

SOT-23 (TO-236)



3,000 pcs per reel

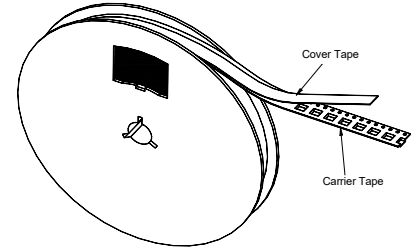

30,000 pcs per box
10 reels per box

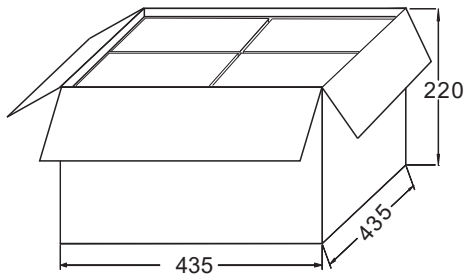

120,000 pcs per carton
4 boxes per carton

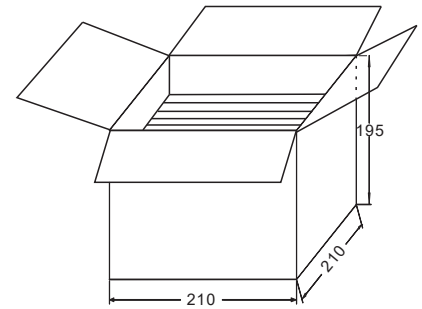

◆ Embossed tape and reel data

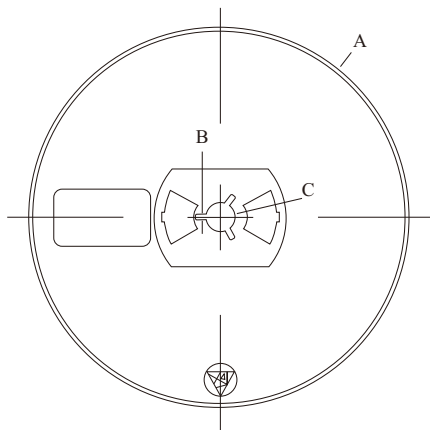

Reel (7")

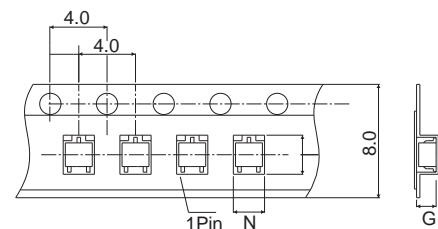
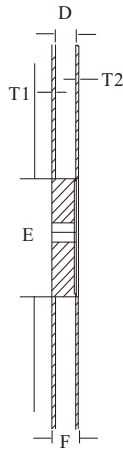

Tape (8mm)

Symbol	Value (unit: mm)
A	Ø 177.8±1
B	2.7±0.2
C	Ø 13.5±0.2
E	Ø 54.5±0.2
F	12.3±0.3
D	9.6+2/-0.3
T1	1.0±0.2
T2	1.2±0.2
N	3.15±0.1
G	1.25±0.1

单击下面可查看定价，库存，交付和生命周期等信息

[>>PJSEMI\(平晶微\)](#)