



Description

The PJ75C Series is a group of positive voltage output 3-terminal linear regulator, capable of delivering 150mA current and working under 40V input voltage. It also features extremely low standby current which is only 5uA, while still keeps very fast load transient response capability. With the extremely low 5uA standby current, PJ75C Series can greatly improve natural life of batteries.

PJ75C includes high accuracy voltage reference, error amplifier, and current limit circuit and output driver module. PJ75C has well load transient response and good temperature characteristic. And it uses trimming technique to guarantee output voltage accuracy within $\pm 2\%$. PJ75C can provide 3.0V, 3.3V, 5.0V, 9.0V, 12V output value. It also can be customized on command.

Features

- Wide Input Voltage Range: 3V~40V
- Maximum Output Current :150mA
- Standard Fixed Output Voltage Options: 3V~12V(customized by every 0.1V step)
- Low Power Consumption : 5.0uA (Typ.)
- PSRR=50dB@1KHz
- Low Dropout Voltage:740mV@ $I_{OUT}=100mA$
- Low Output Voltage Accuracy : $\pm 2\%$
- Current Limit and Short Protection
- Over Temperature Protection
- Available Packages : SOT-23, SOT-23-3 and SOT-89

Applications

- Wearables
- Toys
- Smart Home Application
- Battery Powered Equipment

Typical Application Circuit

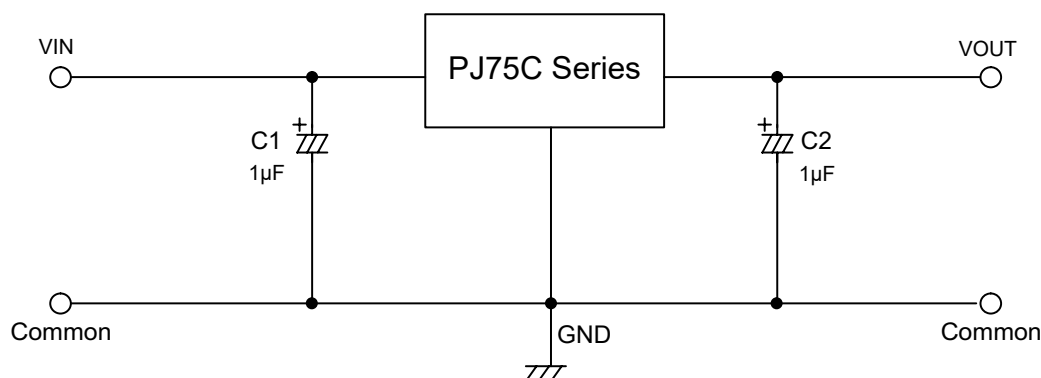

Pin Distribution

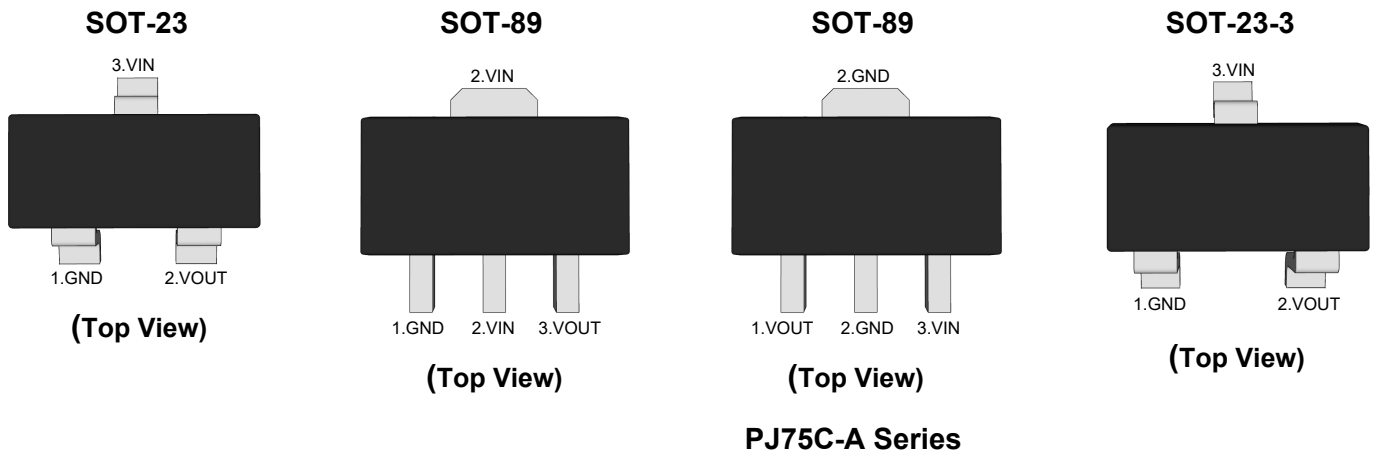

Functional Pin Description

Pin Name	Pin Function
GND	Ground
VOUT	Output Voltage
VIN	Power Input Voltage

Ordering Information

PJ75C □□□□□

- Pin arrangement version number
□(Blank): Normal pin arrangement version
A: A version pin arrangement
- Package Type
SA : SOT-23 SC : SOT-23-3
SQ : SOT-89
- Output Voltage
3V~12V(customized by every 0.1V step)
For example, 30 means product outputs 3.0V
- Output current tap
L: 150mA
- C: Revision NO.
- Series NO.



PJ75C Series Low Dropout Regulators

Ordering Information Continue

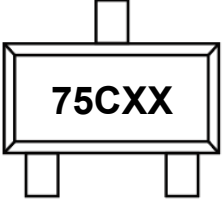
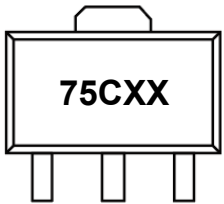
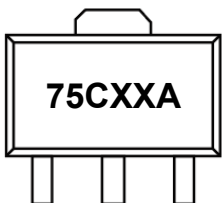
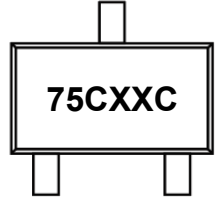
Orderable Device	Package	Reel (inch)	Package Qty (PCS)	Eco Plan ^{Note}	MSL Level	Marking Code
PJ75CL30SA	SOT-23	7	3000	RoHS & Green	MSL1	 XX:Output Voltage e.g. 30:3.0V
PJ75CL33SA						
PJ75CL50SA						
PJ75CL90SA						
PJ75CL120SA						
PJ75CL30SQ	SOT-89	7/13	1000/3000	RoHS & Green	MSL1	 XX:Output Voltage e.g. 30:3.0V
PJ75CL33SQ						
PJ75CL50SQ						
PJ75CL90SQ						
PJ75CL120SQ						
PJ75CL30SQ-A	SOT-89	7/13	1000/3000	RoHS & Green	MSL1	 XX:Output Voltage e.g. 30:3.0V
PJ75CL33SQ-A						
PJ75CL50SQ-A						
PJ75CL90SQ-A						
PJ75CL120SQ-A						
PJ75CL30SC	SOT-23-3	7	3000	RoHS & Green	MSL3	 XX:Output Voltage e.g. 30:3.0V
PJ75CL33SC						
PJ75CL50SC						
PJ75CL90SC						
PJ75CL120SC						

Note:

RoHS: PJ defines "RoHS" to mean semiconductor products that are compliant with the current EU RoHS requirements for all 10 RoHS substances, including the requirement that RoHS substance do not exceed 0.1% by weight in homogeneous materials.

Green: PJ defines "Green" to mean Halogen-Free and Antimony-Free.

Function Block Diagram

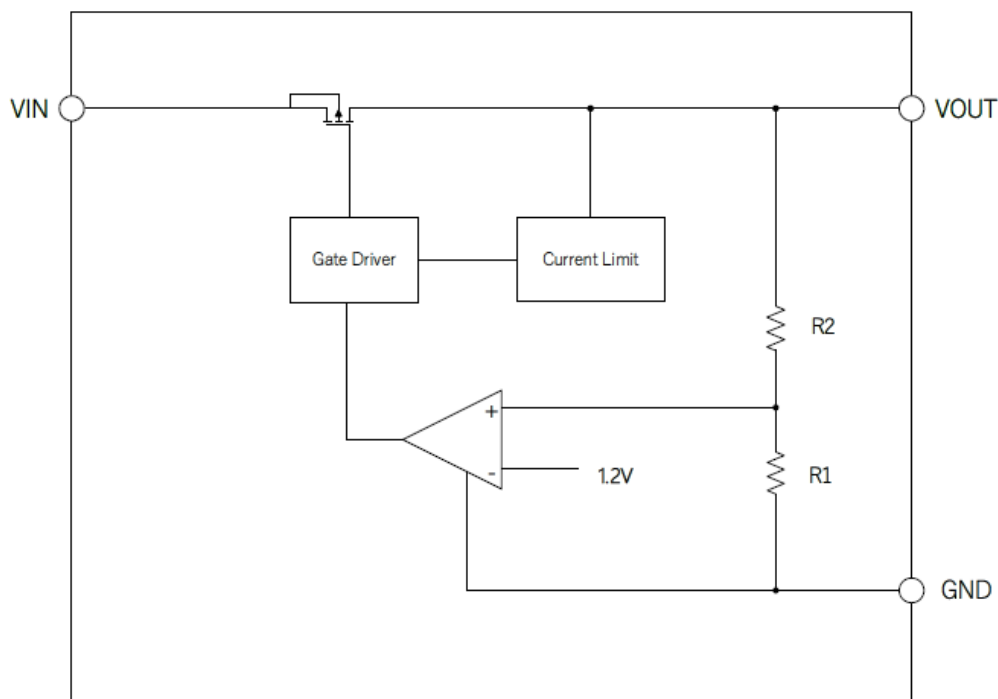



Absolute Maximum Ratings

Ratings at 25°C ambient temperature unless otherwise specified.

Parameter		Value	Unit
Input Voltage		42	V
Output Voltage		-0.3 ~ +20	V
Power Dissipation	SOT-23	300	mW
	SOT-23-3	400	mW
	SOT-89	600	mW
Thermal Resistance, Junction-to-Ambient	SOT-23	380	°C/W
	SOT-23-3	300	°C/W
	SOT-89	180	°C/W
Operating Junction Temperature		125	°C
Operating Ambient Temperature		-40 ~ +85	°C
Storage Temperature Range		-55 ~ +125	°C
Lead Temperature & Time		260°C, 10S	--
ESD Voltage	HBM	2	KV

Note1: Exceed these limits to damage to the device. Exposure to absolute maximum rating conditions may affect.

Recommended Operating Conditions

Parameter	Value	Unit
Supply Voltage	3~40	V
Maximum Output Current	150	mA
Operating Ambient Temperature	-40 ~ +85	°C



Electrical Characteristics

(All tests are conducted under ambient temperature 25°C and within a short period of time 20ms.)

Parameter	Symbol	Test Conditions	Min.	Typ.	Max.	Unit
Input Voltage	V_{IN}		3	--	40	V
Output Voltage	V_{OUT}		3	--	12	V
Output Voltage Accuracy	ΔV_{OUT}		-2	--	+2	%
Maximum Output Current	$I_{OUT(MAX)}$	$V_{IN}-V_{OUT}=2V$	150	--	--	mA
Quiescent Current	I_Q	$I_{OUT}=0mA$	--	5	10	μA
Dropout Voltage	V_{DROP}	$V_{OUT}>3V, I_{OUT}=100mA$	--	740	1000	mV
Line Regulation	ΔV_{LINE}	$I_{OUT}=1mA$	--	0.01	0.1	%/V
Load Regulation	ΔV_{LOAD}	$1mA<I_{OUT}<100mA$	--	2	4	%
Current Limit	I_{Limit}		--	200	--	mA
Short Current	I_{Short}	OUT Short to GND	--	200	--	mA
Power Supply Rejection Ratio	PSRR	$V_{OUT}=3.3V, I_{OUT}=1mA, f=1KHz$	--	50	--	dB
Startup Time	t_{start}		--	500	--	μS
OTP			--	165	--	°C
OTP hysteresis			--	30	--	°C



Typical Characteristics Curves

$C_{IN}=C_{OUT}=1\mu F, T_A=25^\circ C$, unless otherwise specified.

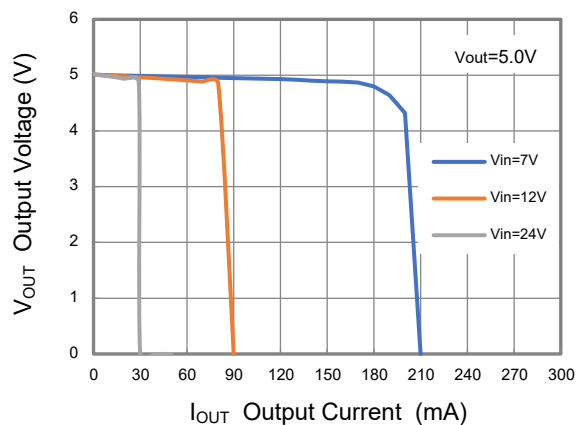
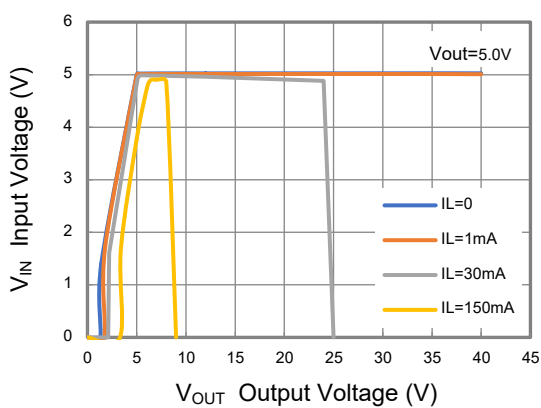
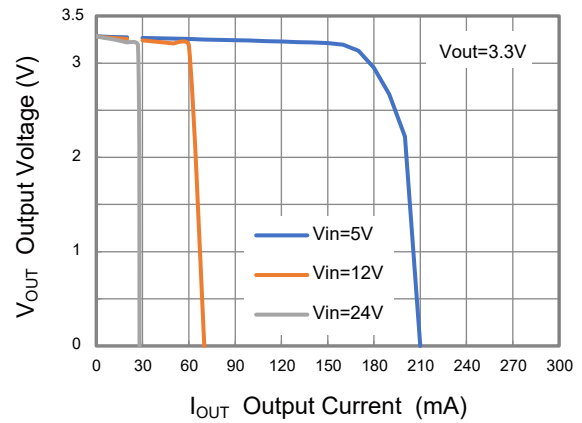
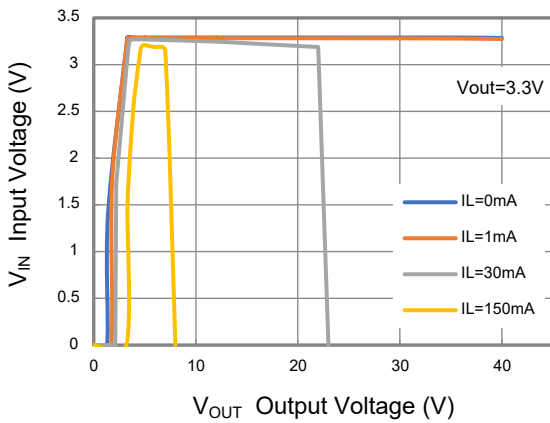
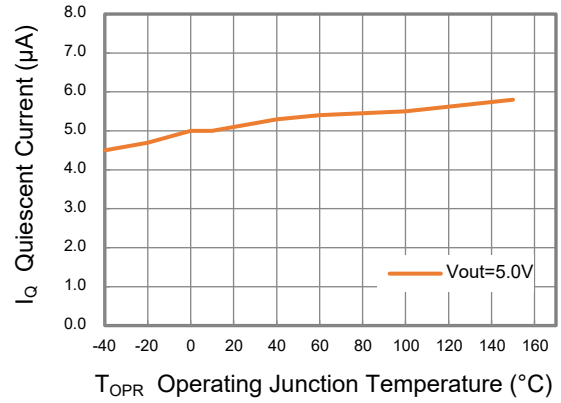
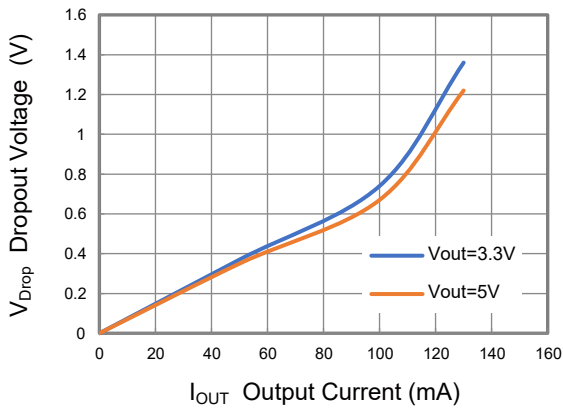



PJ75C Series Low Dropout Regulators

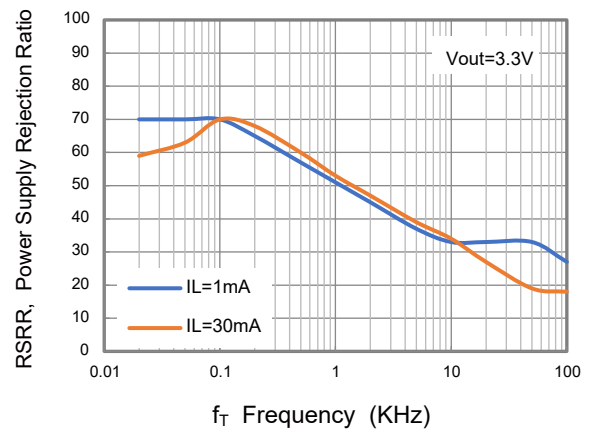
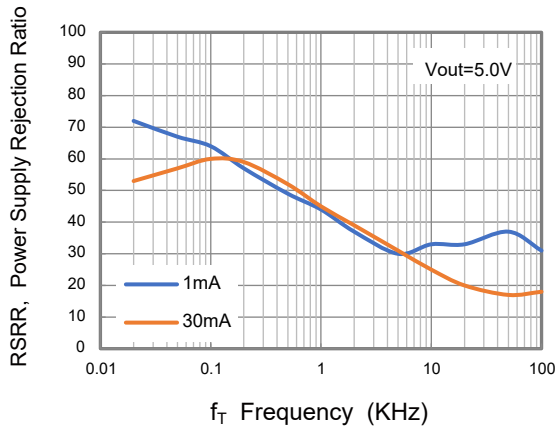

V_{IN} fast on 150mA, $V_{OUT}=3.3V$

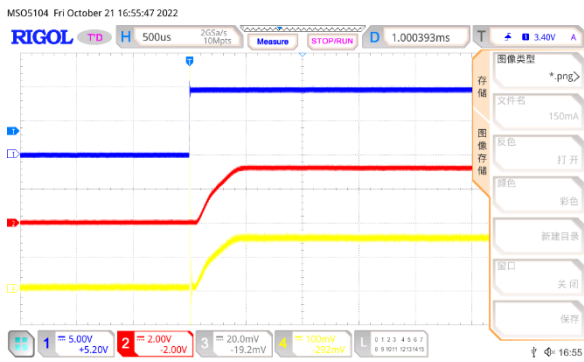

V_{IN} fast off 150mA, $V_{OUT}=3.3V$



V_{IN} fast on 150mA, $V_{OUT}=5.0V$

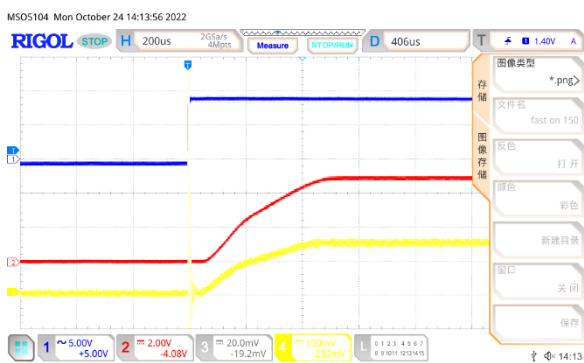

V_{IN} fast off 150mA, $V_{OUT}=5.0V$

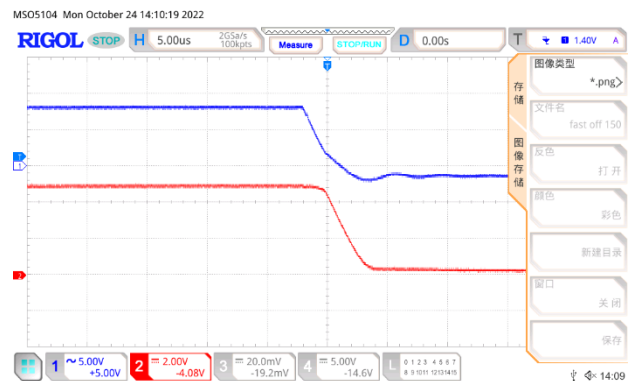

V_{IN} slow on/off 150mA, $V_{OUT}=3.3V$

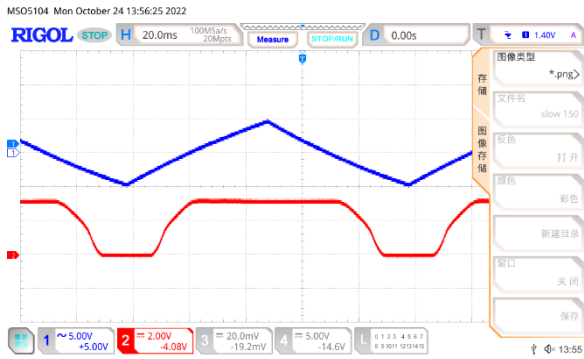

V_{IN} slow on/off 150mA, $V_{OUT}=5.0V$



Line transient $V_{OUT}=3.3V$, $I_{OUT}=1mA$



Line transient $V_{OUT}=5.0V$, $I_{OUT}=1mA$



Load transient $V_{OUT}=3.3V$, $I_{OUT}=1mA-50mA$



Load transient $V_{OUT}=5.0V$, $I_{OUT}=1mA-40mA$

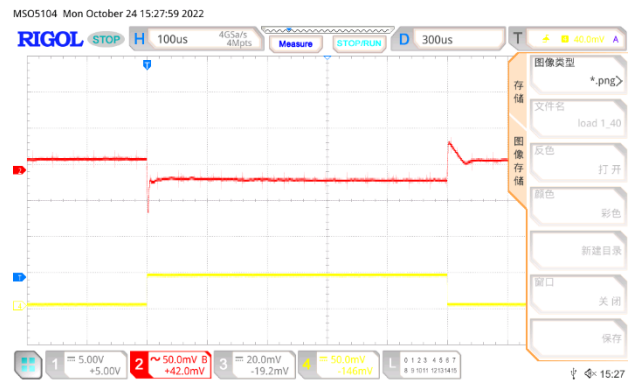



Function Descriptions

A minimum of 1uF capacitor must be connected from Vout to ground to insure stability. Input capacitor of 1uF is recommended to ensure the input voltage does not sag below the minimum dropout voltage during load transient event. Vin pin must always be dropout voltage higher than Vout in order for the device to regulate properly.

Applications Information

Like any low-dropout regulators, PJ75C requires input and output decoupling capacitors. These capacitors must be correctly selected for good performance. Both input and output capacitors are recommended to be placed as close to chip pin as possible.

Capacitor Selection

A Normally, use a 1uF capacitor on the input and a 1uF capacitor on the output of the PJ75C. Larger input capacitor values and lower ESR (X5R, X7R) provide better supply noise rejection and transient response.

Input-Output (Dropout) Voltage

A regulator's minimum input-to-output voltage differential (dropout voltage) determines the lowest usable supply voltage. In battery-powered systems, this determines the useful end-of-life battery voltage. Because the device uses a PMOS, its dropout voltage is a function of drain to source on resistance, R_{DS(on)}, multiplied by the load current:

$$V_{\text{DROP}} = V_{\text{IN}} - V_{\text{OUT}} = R_{\text{DS(on)}} \times I_{\text{OUT}}$$

Current Limit and Thermal Shutdown Protection

In order to prevent overloading or thermal condition from damaging the device, PJ75C has internal thermal and current limiting functions designed to protect the device. It will rapidly shut off PMOS pass element during overloading or over temperature condition.

Thermal Considerations

The PJ75C series can deliver a current of up to 150mA over the full operating junction temperature range. However, the maximum output current must be controlled at higher ambient temperature to ensure the junction temperature does not exceed 150°C. With all possible conditions, the junction temperature must be within the range specified under operating conditions. Power dissipation can be calculated based on the output current and the voltage drop across regulator.

$$P_D = (V_{\text{IN}} - V_{\text{OUT}}) \times I_{\text{OUT}}$$

The final operating junction temperature for any set of conditions can be estimated by the following thermal equation:

$$P_{D(\text{max})} = (T_{J(\text{max})} - T_A) / R_{\theta\text{JA}}$$

Where T_{J(max)} is the maximum junction temperature of the die (150°C) and T_A is the maximum ambient temperature. When junction temperature exceeds 150°C, over temperature protection may be triggered to prevent device from over heat.

PCB Layout

An input capacitance of 1uF is required between the PJ75C input pin and ground (the amount of the capacitance may be increased without limit), this capacitor must be located a distance of not more than 1cm from the input and return to a clean analog ground. Input capacitor can filter out the input voltage spikes caused by the surge current due to the inductive effect of the package pin and the printed circuit board's routing wire. Otherwise, the actual voltage at the Vin pin may exceed the absolute maximum rating. The output capacitor also must be located a distance of not more than 1cm from output to a clean analog ground. Because it can filter out the output spike caused by the surge current due to the inductive effect of the package pin and the printed circuit board's routing wire.



PJ75C Series Low Dropout Regulators

Package Outline

SOT-23

Dimensions in mm

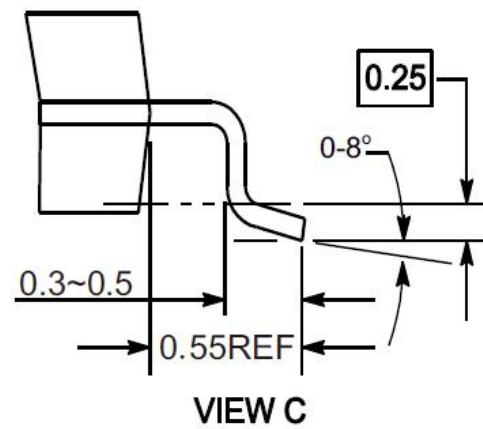
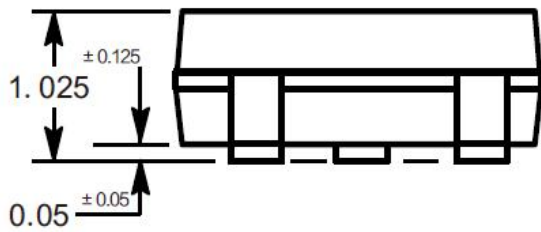
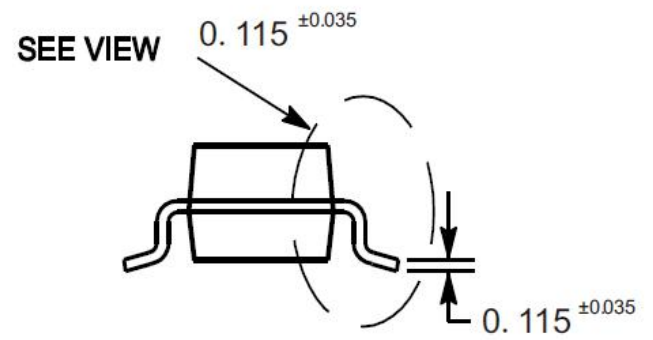
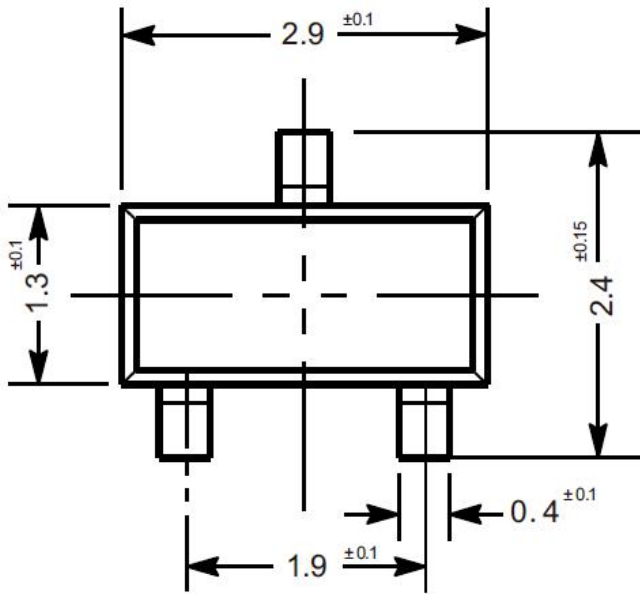

Package Outline

SOT-23-3

Dimensions in mm

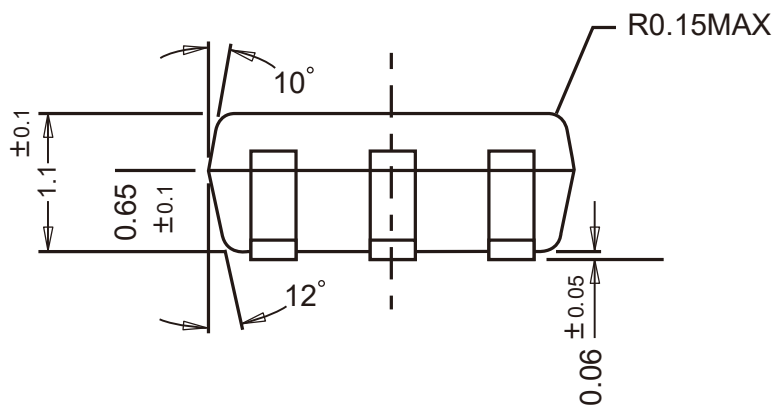
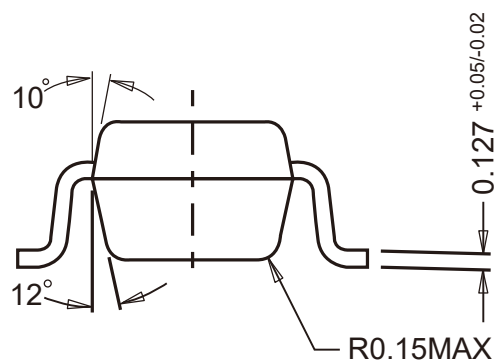
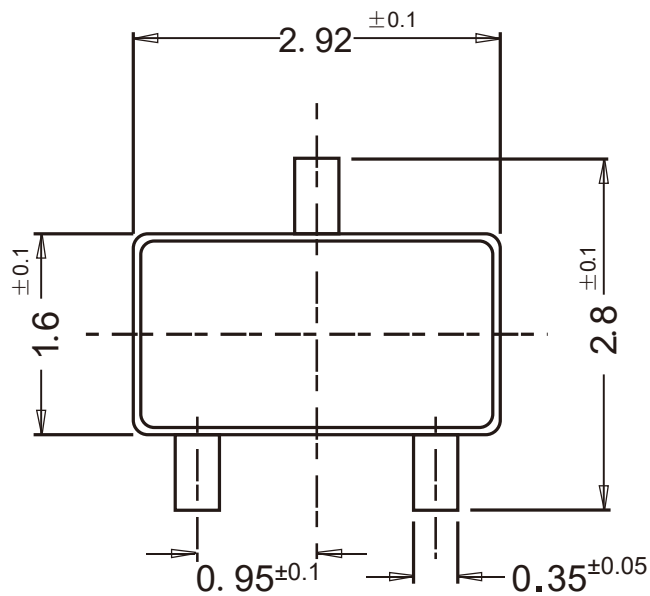



Package Outline

SOT-89

Dimensions in mm

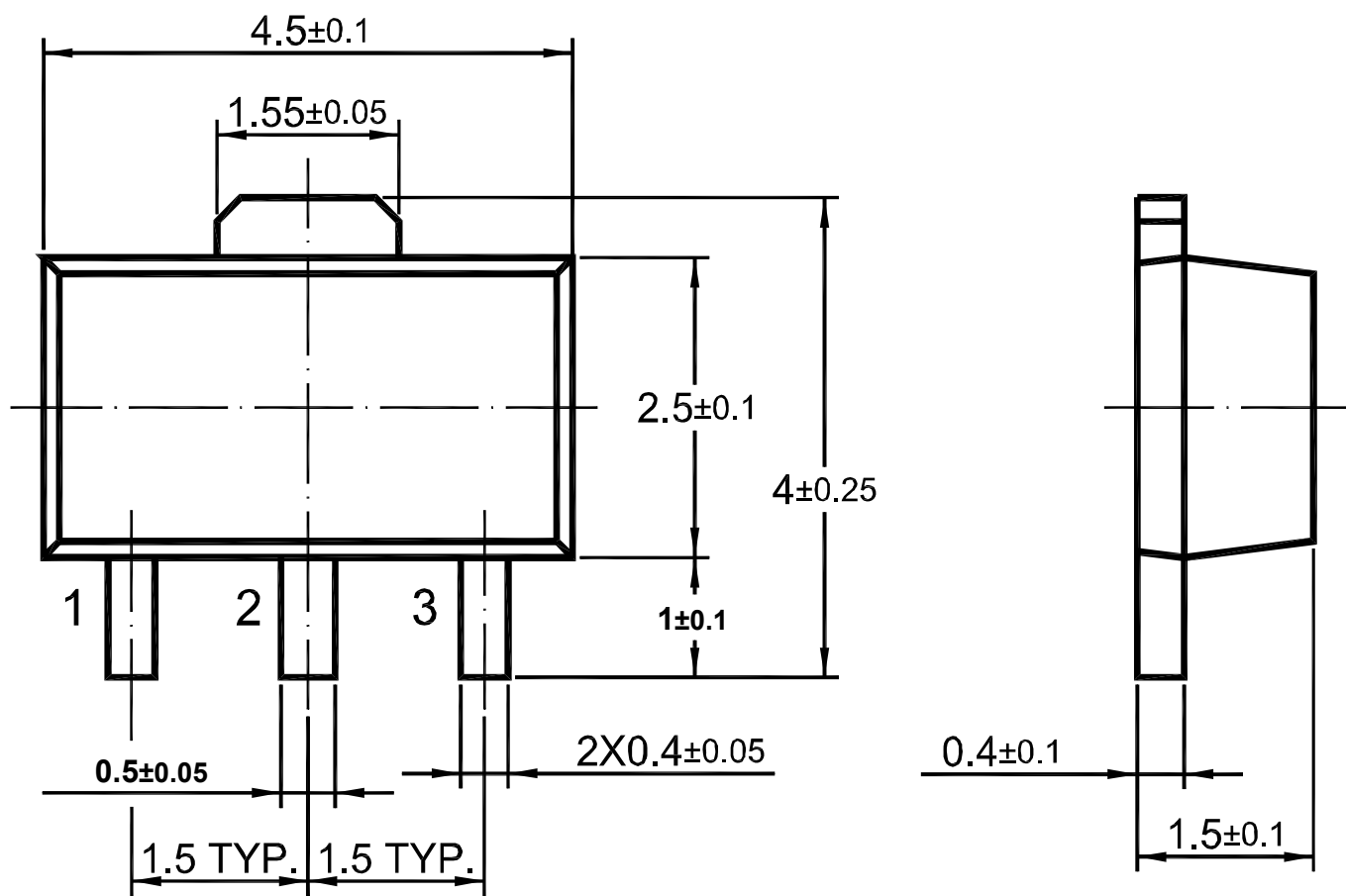

Conditions of Soldering and Storage

◆ Recommended condition of reflow soldering

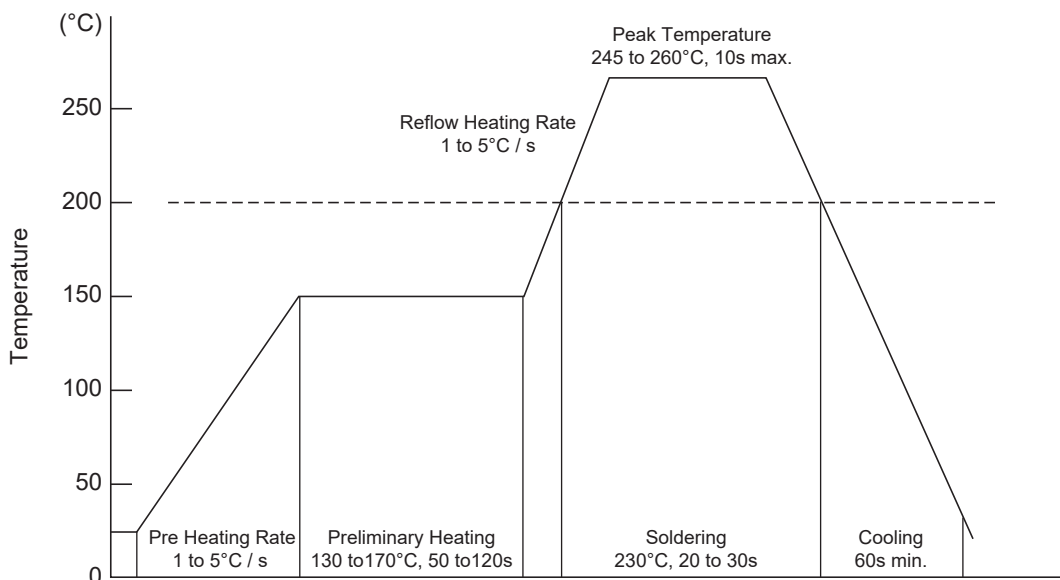

Recommended peak temperature is over 245°C. If peak temperature is below 245°C, you may adjust the following parameters:

- Time length of peak temperature (longer)
- Time length of soldering (longer)
- Thickness of solder paste (thicker)

◆ Conditions of hand soldering

- Temperature: 300°C
- Time: 3s max.
- Times: one time

◆ Storage conditions

- **Temperature**
5 to 40°C
- **Humidity**
30 to 80% RH
- **Recommended period**
One year after manufacturing

Package Specifications (SOT-23/SOT-23-3)

- The method of packaging

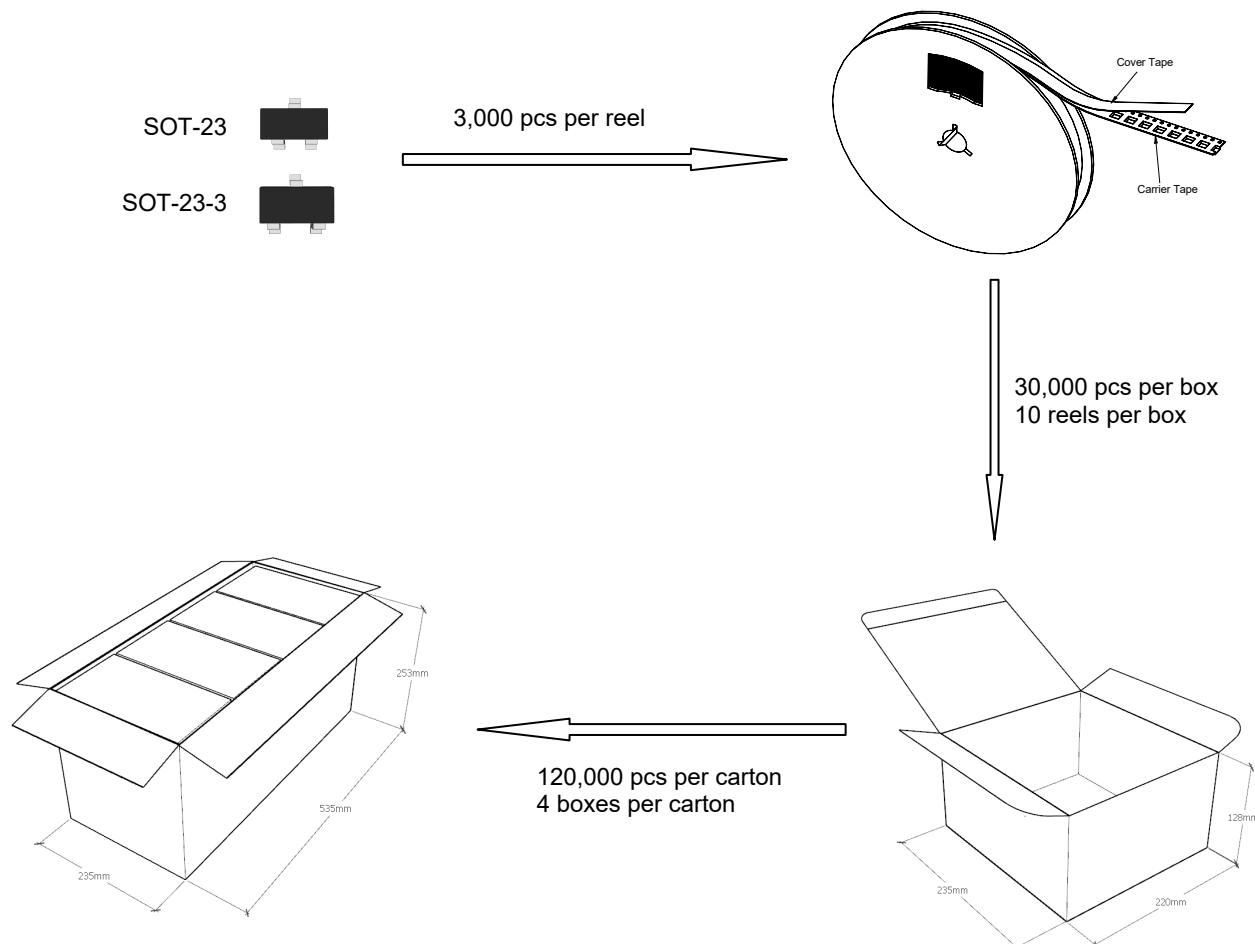

◆ reel data

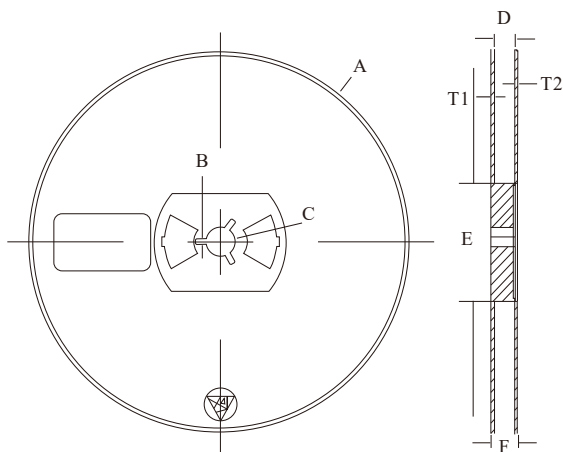

Symbol	Value (unit: mm)
A	Ø 177.8±1
B	2.7±0.2
C	Ø 13.5±0.2
E	Ø 54.5±0.2
F	12.3±0.3
D	9.6+2/-0.3
T1	1.0±0.2
T2	1.2±0.2

Package Specifications

- The method of packaging (1,000PCS/Reel&7inches)

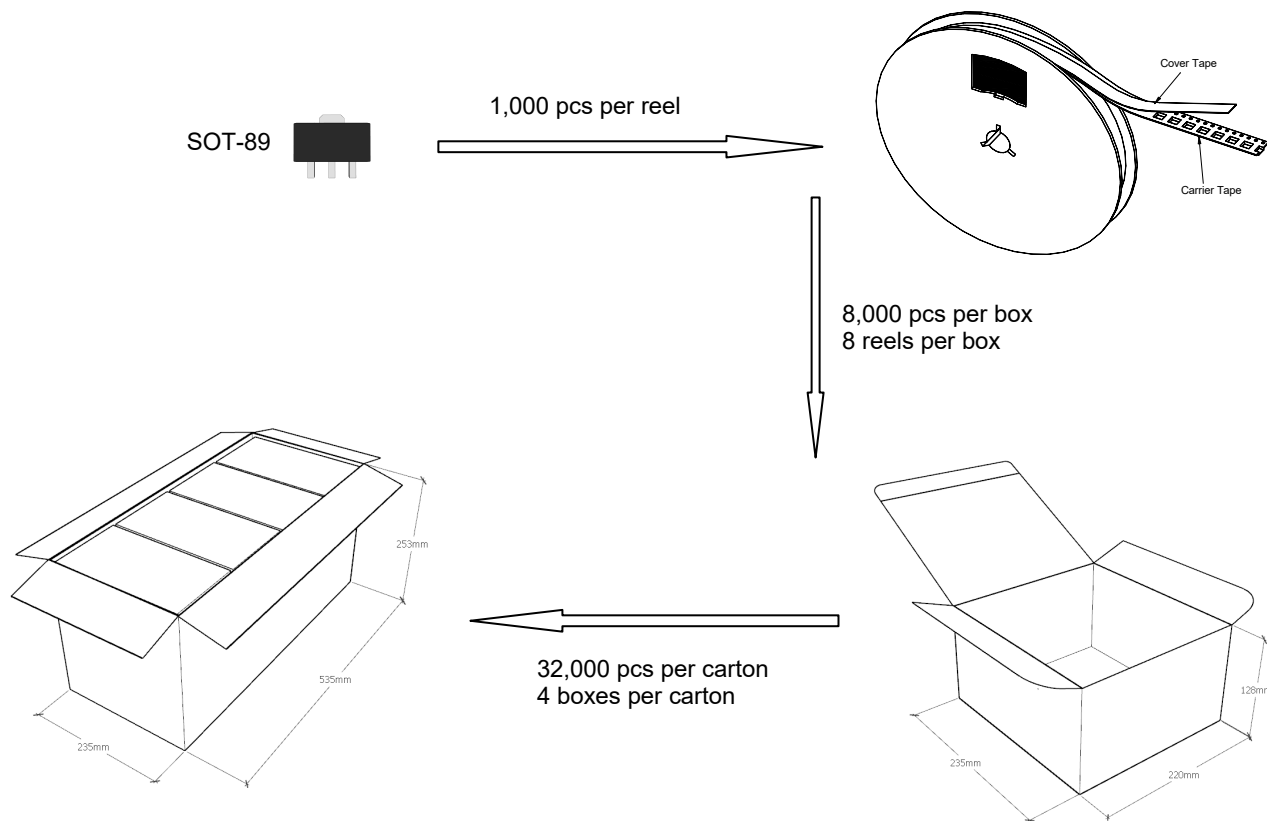

◆ reel data

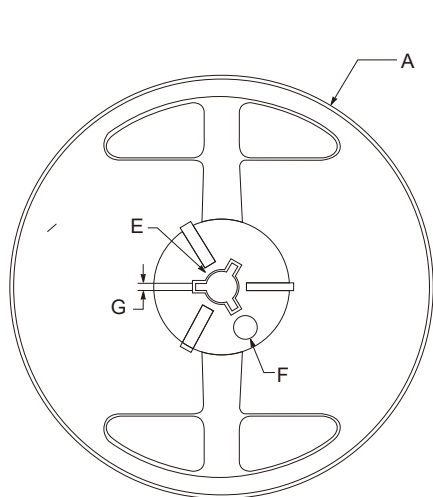

Reel (7")

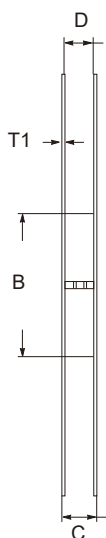

symbol	Value(unit:mm)
A	$\Phi 179 \pm 1$
B	60.5 ± 0.2
C	15.3 ± 0.3
D	$12.5 \sim 13.7$
E	$\Phi 13.5 \pm 0.2$
F	$\Phi 10.0 \pm 0.2$
G	2.7 ± 0.2
T1	1.0 ± 0.2

Package Specifications

- The method of packaging (3,000PCS/Reel&13inches)

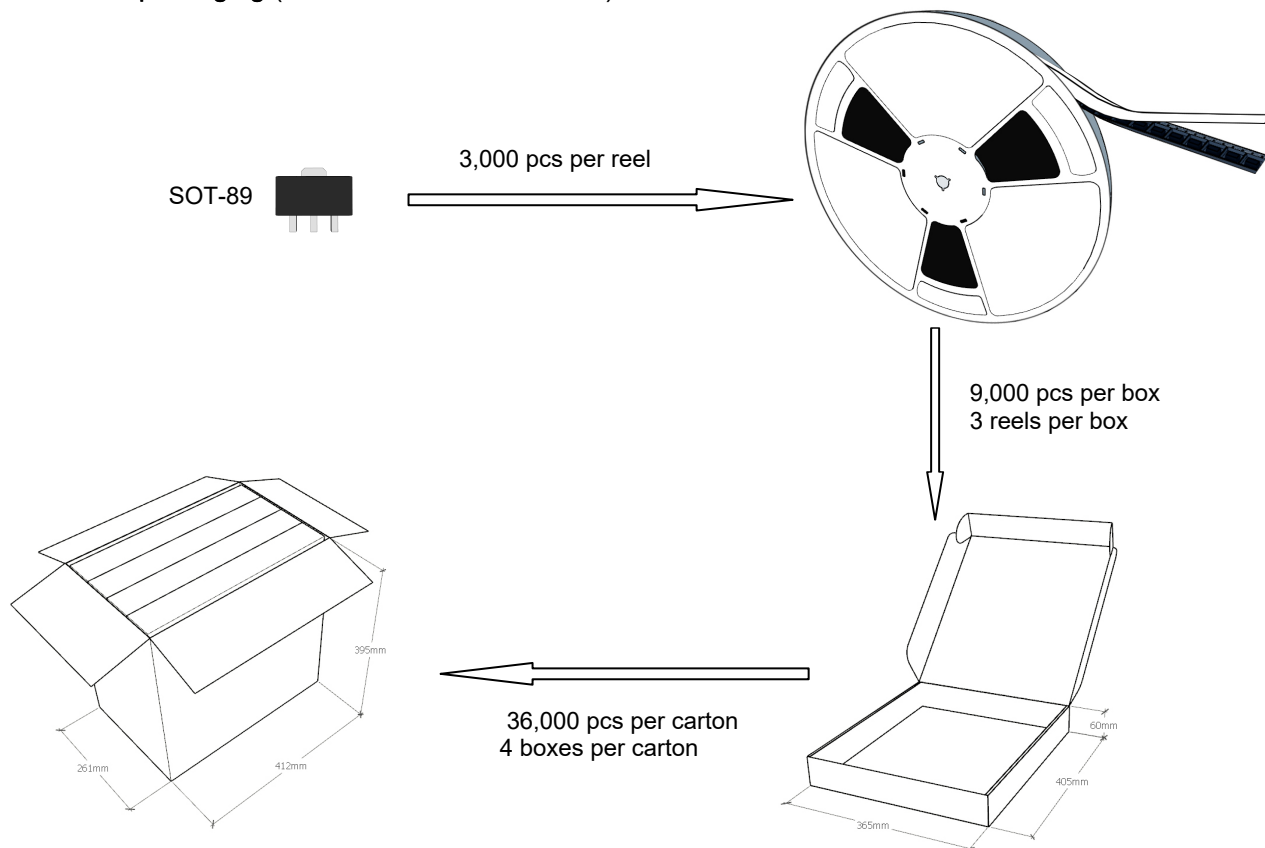

◆ reel data

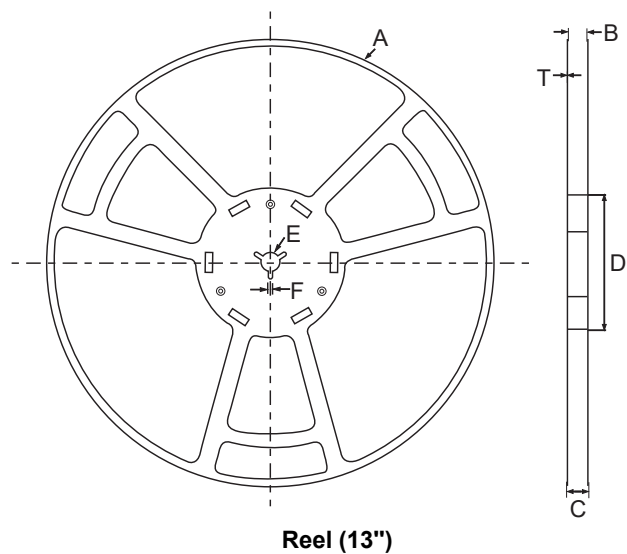

symbol	Value(unit:mm)
A	$\phi 330\pm 1$
B	12.7 ± 0.5
C	16.5 ± 0.3
D	$\phi 99.5\pm 0.5$
E	$\phi 13.6\pm 0.3$
F	2.8 ± 0.3
T	1.9 ± 0.2

◆ Embossed tape data

SOT-23

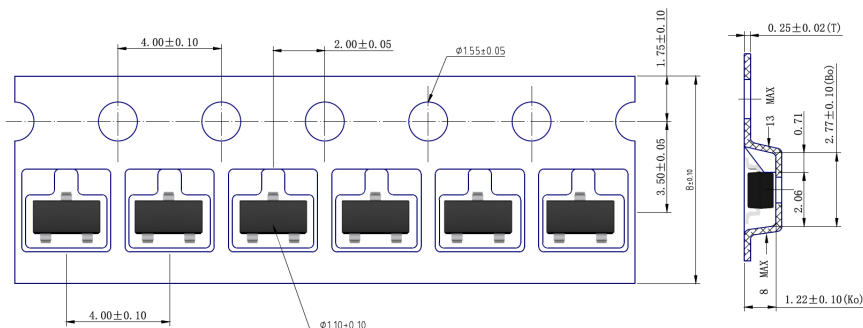

SOT-23-3

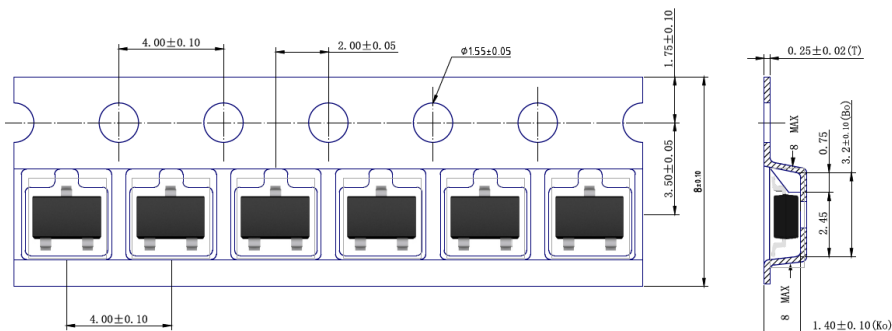

SOT-89

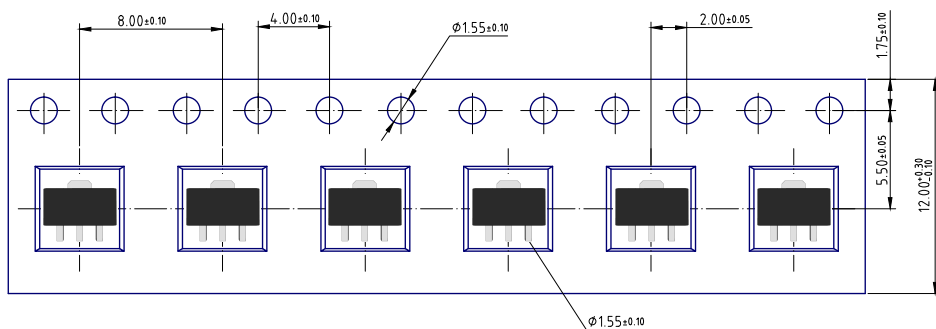

单击下面可查看定价，库存，交付和生命周期等信息

[>>PJSEMI\(平晶微\)](#)