



Description

The LM358 consists of two independent voltage comparators. It can be a single power source or a double power source and the power consumption current of the power supply is independent of the power voltage. Applications include audio amplifiers, industrial controls, DC gain components, and all conventional operational amplifiers. Adopt the encapsulation form of SOP8/ DIP8

Features

- Work with single or double power supply
- Contains two operational amplifiers
- Logic circuit matching
- Low consumption

DIP8

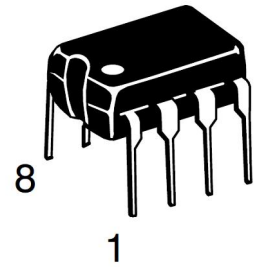

SOP8

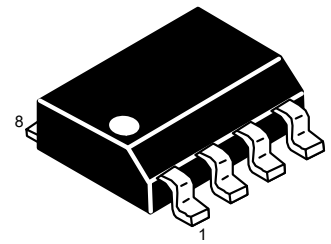

Pin Distribution

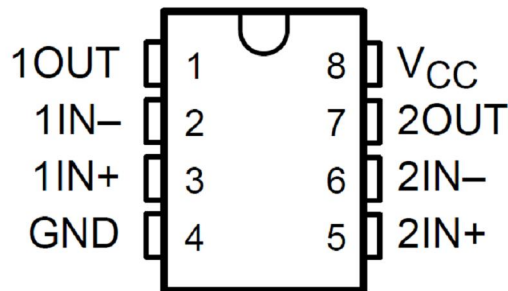

Block Diagram(Each op-amp)

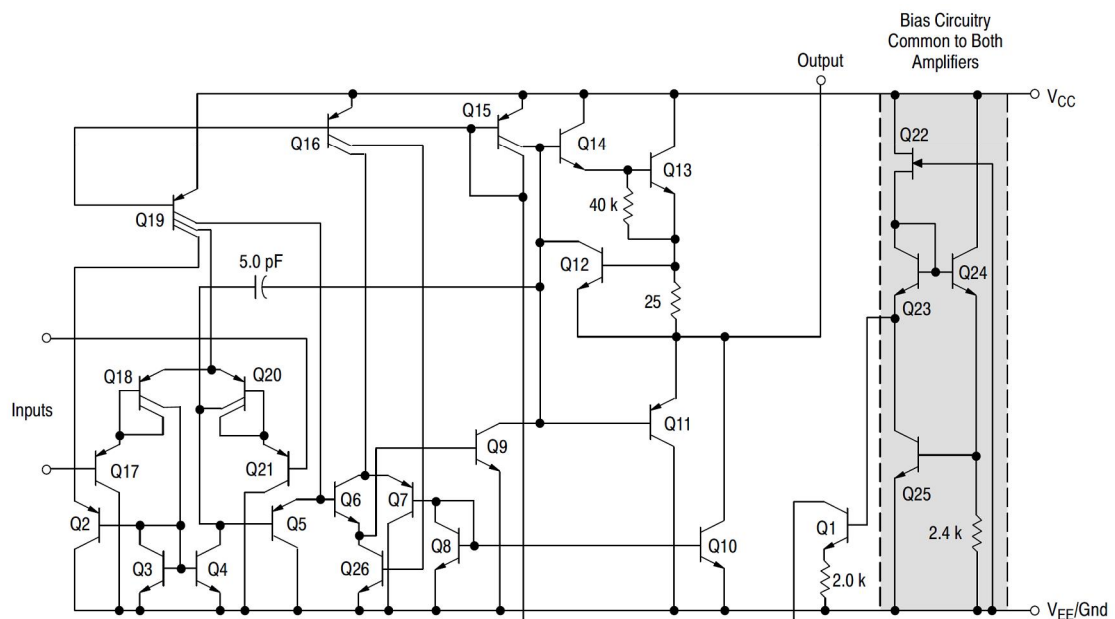

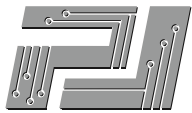

Absolute Maximum Ratings (T_A=25°C)

Parameter	Symbol	Value	Units
Supply Voltage	V _{CC}	32 or ±16	V
Differential Input Voltage	V _{I(DIFF)}	32	V
Common-mode Input Voltage	V _{ICR}	-0.3~32	V
Output Short Circuit Duration(V≤15V Ta=25°C)	t _{SC}	Continuous	-
Input Current (V _{IN} <-0.3V)	I _{IN}	50	mA
Operating Temperature Range	T _{OPR}	0 to 70	°C
Storage Temperature Range	T _{STG}	-65 to 150	°C

Electrical Characteristics

V_{CC} = 5.0 V, T_A = 25°C, unless otherwise noted.

Parameter	Symbol	Conditions	Min.	Max.	Max.	Units
Input Offset Voltage	V _{IO}		--	2	5	mV
Input offset current	I _{IO}	I _{IN(+)} or I _{IN(-)} , V _{CM} =0V	--	45	150	nA
Input bias current	I _{IB}	I _{IN(+)} - I _{IN(-)} , V _{CM} =0V	--	3	30	nA
Common-mode input voltage range	V _{ICR}	V _{CC} =30V	0	--	V _{CC} -1.5	mV
Large-signal differential voltage amplification	A _{VD}	V _{CC} = 15 V, V _O =1V to 11 V, R _L ≥ 2 kΩ	50	100	--	V/mV
Common Mode Rejection	CMR	V _{CM} = 0~V _{CC} -1.5 V	65	90	--	dB
Power Supply Rejection	PSR	V _{CC} = 5~30 V	65	100	--	dB
Output Voltage–High Limit	V _{OH}	V _{CC} =30V, R _L = 2 kΩ	26	--	--	V
		V _{CC} =30V, R _L =10 kΩ	27	28	--	V
Output Voltage–Low Limit	V _{OL}	V _{CC} =5V, R _L =10 kΩ	--	5	20	mV
Output Source Current	I _{O+}	V _{IN(+)} =1V, V _{IN(-)} =0V, V _{CC} =15V, V _O =2V	20	40	--	mA
Output Sink Current	I _{O-}	V _{IN(-)} =1V, V _{IN(+)} =0V, V _{CC} =15V, V _O =2V	10	20	--	mA
		V _{IN(-)} =1V, V _{IN(+)} =0V, V _{CC} =15V, V _O =200mV	12	50	--	μA
Output Short Circuit to Ground	I _{SC}	V _{CC} =15V	--	40	60	mA
Power Supply Current	I _{CC}	V _{CC} =30V, R _L =∞	--	1	2	mA
		V _{CC} =5V, R _L =∞	--	0.5	1.2	mA



Typical applications

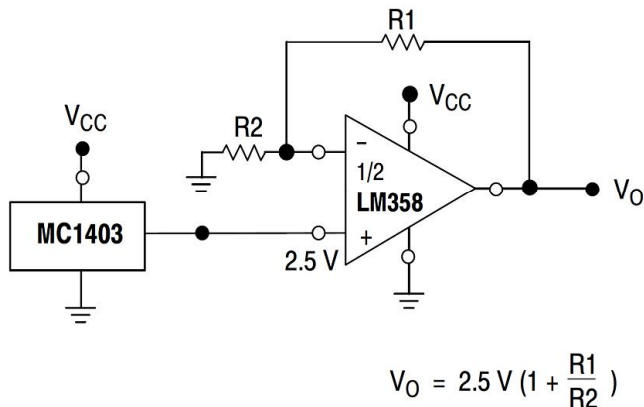

Voltage Reference

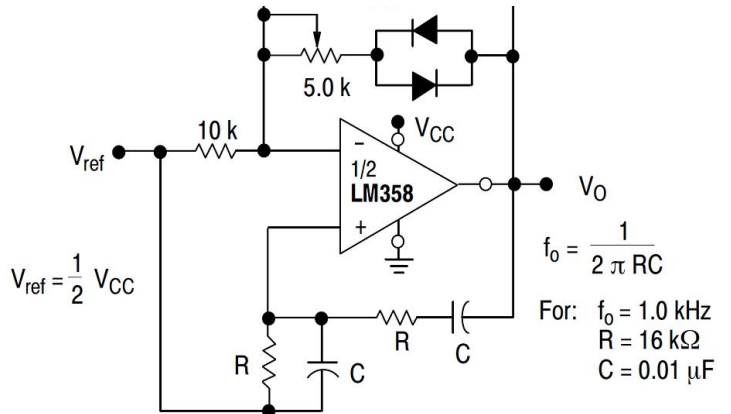

Wien-bridge oscillator

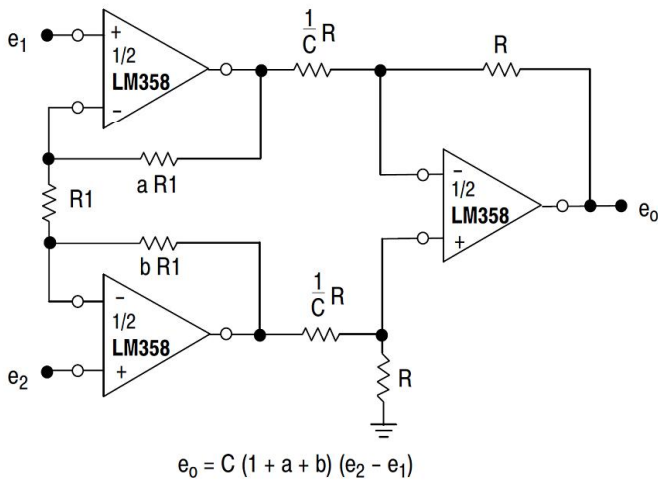

High impedance differential amplifier

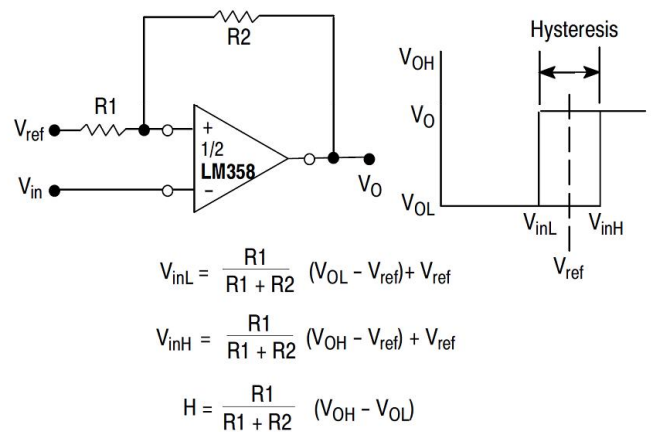

Hysteresis Comparator

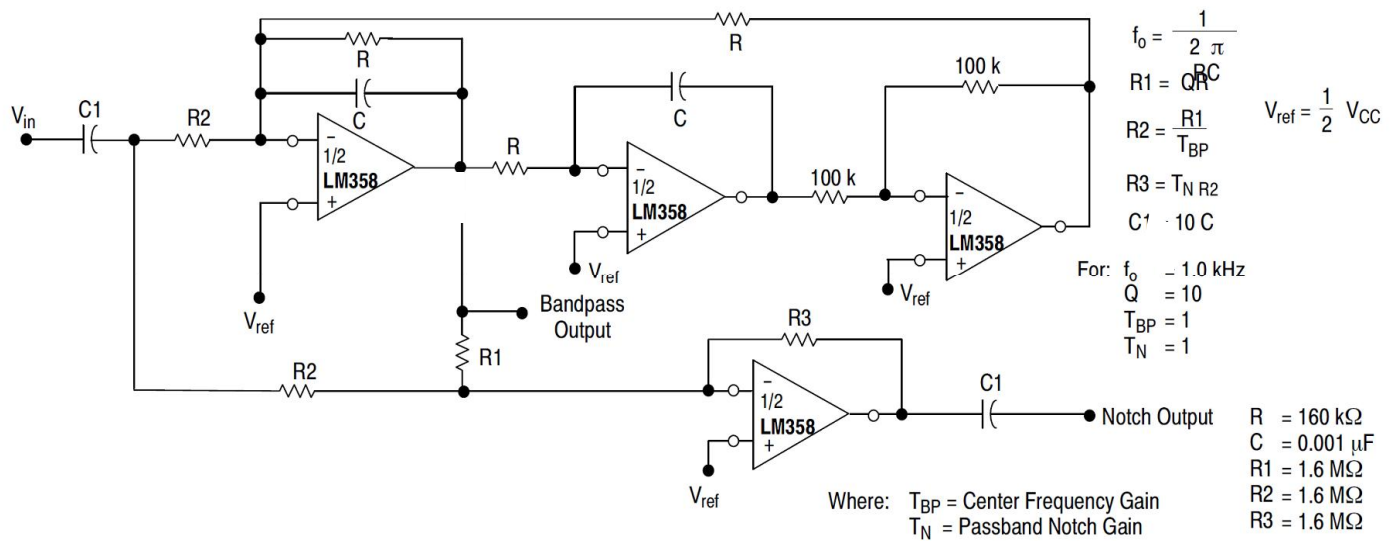

Second-Order Filter



Package Outline

DIP-8

unit: mm

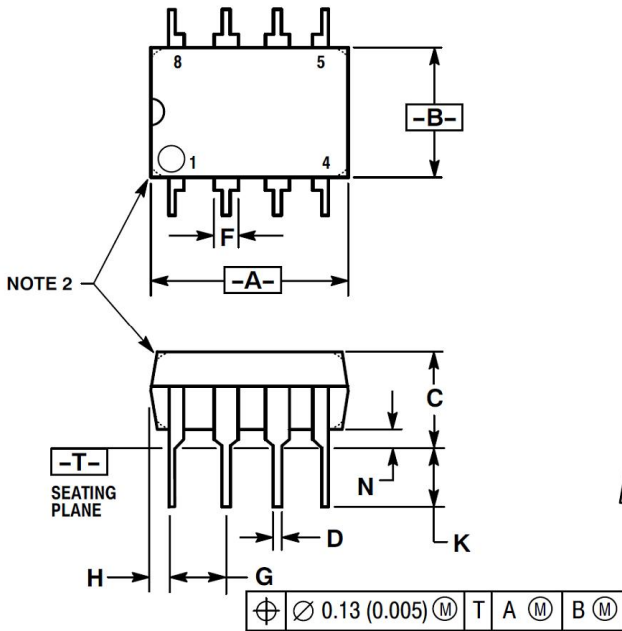

NOTES:

1. DIMENSION L TO CENTER OF LEAD WHEN FORMED PARALLEL.
2. PACKAGE CONTOUR OPTIONAL (ROUND OR SQUARE CORNERS).
3. DIMENSIONING AND TOLERANCING PER ANSI Y14.5M, 1982.

DIM	MILLIMETERS		INCHES	
	MIN	MAX	MIN	MAX
A	9.40	10.16	0.370	0.400
B	6.10	6.60	0.240	0.260
C	3.94	4.45	0.155	0.175
D	0.38	0.51	0.015	0.020
F	1.02	1.78	0.040	0.070
G	2.54 BSC		0.100 BSC	
H	0.76	1.27	0.030	0.050
J	0.20	0.30	0.008	0.012
K	2.92	3.43	0.115	0.135
L	7.62 BSC		0.300 BSC	
M	---	10°	---	10°
N	0.76	1.01	0.030	0.040



Package Outline

SOP-8

unit: mm

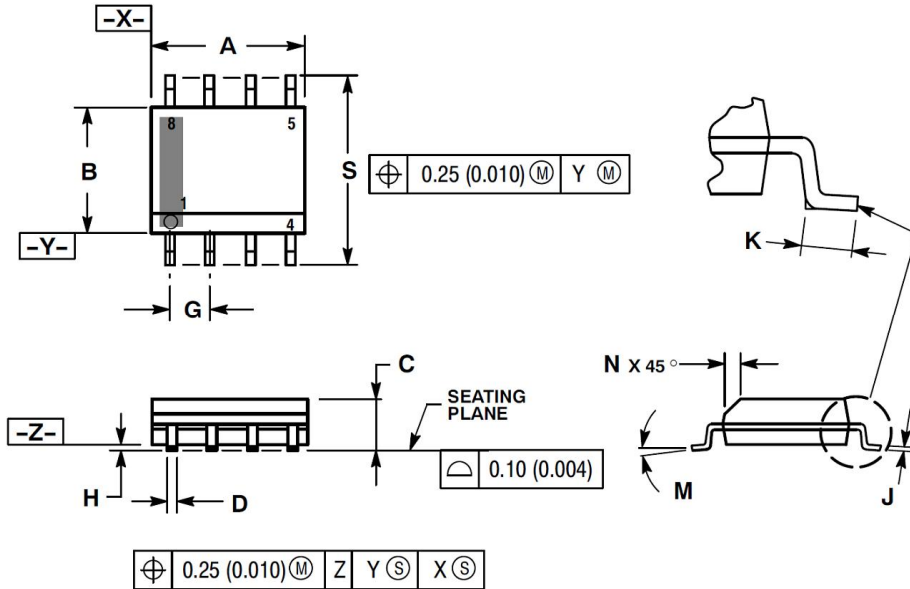

NOTES:

1. DIMENSIONING AND TOLERANCING PER ANSI Y14.5M, 1982.
2. CONTROLLING DIMENSION: MILLIMETER.
3. DIMENSION A AND B DO NOT INCLUDE MOLD PROTRUSION.
4. MAXIMUM MOLD PROTRUSION 0.15 (0.006) PER SIDE.
5. DIMENSION D DOES NOT INCLUDE DAMBAR PROTRUSION. ALLOWABLE DAMBAR PROTRUSION SHALL BE 0.127 (0.005) TOTAL IN EXCESS OF THE D DIMENSION AT MAXIMUM MATERIAL CONDITION.
6. 751-01 THRU 751-06 ARE OBSOLETE. NEW STANDARD IS 751-07.

DIM	MILLIMETERS		INCHES	
	MIN	MAX	MIN	MAX
A	4.80	5.00	0.189	0.197
B	3.80	4.00	0.150	0.157
C	1.35	1.75	0.053	0.069
D	0.33	0.51	0.013	0.020
G	1.27 BSC		0.050 BSC	
H	0.10	0.25	0.004	0.010
J	0.19	0.25	0.007	0.010
K	0.40	1.27	0.016	0.050
M	0°	8°	0°	8°
N	0.25	0.50	0.010	0.020
S	5.80	6.20	0.228	0.244

单击下面可查看定价，库存，交付和生命周期等信息

[>>PJSEMI\(平晶微\)](#)