



# PJM02B60SA

## N- Enhancement Mode Field Effect Transistor

### Features

- ◆  $R_{DS(ON)} < 85m\Omega @ V_{GS} = 10V$   
 $R_{DS(ON)} < 120m\Omega @ V_{GS} = 4.5V$   
 $V_{DS}=60V, I_D=2A$
- ◆ High power and current handing capability

SOT-23

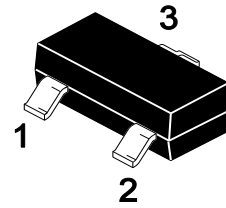

### Schematic diagram

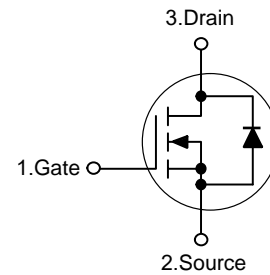

### Applications

- ◆ DC/DC Converter
- ◆ Battery Switch

### Absolute Maximum Ratings

Ratings at 25°C ambient temperature unless otherwise specified.

Parameter	Symbol	Value	Unit
Drain-Source Voltage	$V_{DS}$	60	V
Gate-Source Voltage	$V_{GS}$	$\pm 20$	V
Continuous Drain Current	$I_D$	2	A
Pulsed Drain Current <sup>Note1</sup>	$I_{DM}$	10	A
Total Power Dissipation	$P_D$	0.9	W
Operating Junction Temperature	$T_J$	150	°C
Storage Temperature	$T_{STG}$	- 55 to + 150	°C

### Thermal Characteristics

Parameter	Symbol	Value	Unit
Thermal Resistance, Junction to Ambient <sup>Note2</sup>	$R_{\theta JA}$	139	°C/W



**Electrical Characteristics** ( $T_A=25^{\circ}\text{C}$  unless otherwise noted)

Parameter	Symbol	Test Condition	Min	Type	Max	Unit
<b>Static Characteristics</b>						
Drain-Source Breakdown Voltage	$V_{(BR)DSS}$	$V_{GS} = 0V, I_D = 250\mu A$	60			V
Zero Gate Voltage Drain Current	$I_{DSS}$	$V_{DS} = 60V, V_{GS} = 0V$			1	$\mu A$
Gate-Body Leakage Current	$I_{GSS}$	$V_{GS} = \pm 20V, V_{DS} = 0V$			$\pm 100$	nA
Gate Threshold Voltage <sup>Note3</sup>	$V_{GS(th)}$	$V_{DS} = V_{GS}, I_D = 250\mu A$	1	1.3	2	V
Drain-Source On-Resistance <sup>Note3</sup>	$R_{DS(on)}$	$V_{GS} = 10V, I_D = 3A$			105	m $\Omega$
		$V_{GS} = 4.5V, I_D = 2A$			125	
Forward Transconductance <sup>Note3</sup>	$g_{FS}$	$V_{DS} = 15V, I_D = 2A$		3		S
<b>Dynamic Characteristics</b>						
Input Capacitance	$C_{iss}$	$V_{DS} = 30V, V_{GS} = 0V, f = 1MHz$		510		pF
Output Capacitance	$C_{oss}$			34		
Reverse Transfer Capacitance	$C_{rss}$			26		
<b>SWITCHING Characteristics</b>						
Total Gate Charge	$Q_g$	$V_{DS} = 30V, I_D = 3A, V_{GS} = 4.5V$		7.5		nC
Gate-Source Charge	$Q_{gs}$			1.4		
Gate-Drain Charge	$Q_{gd}$			3		
Turn-On Delay Time	$t_{d(on)}$	$V_{GS} = 10V, V_{DD} = 30V, I_D = 1.5A, R_G = 1\Omega$		6		ns
Turn-On Rise Time	$t_r$			15		
Turn-Off Delay Time	$t_{d(off)}$			15		
Turn-Off Fall Time	$t_f$			10		
<b>Source-Drain Diode characteristics</b>						
Body Diode Voltage	$V_{SD}$	$I_S = 3A, V_{GS} = 0V$			1.2	V

**Notes :**

1. Repetitive rating : Pulse width limited by junction temperature.
2. Surface Mounted on FR4 Board,  $t \leq 10$  sec.
3. Pulse Test : Pulse Width  $\leq 300\mu s$ , Duty Cycle  $\leq 2\%$ .



### Typical Characteristics Curves

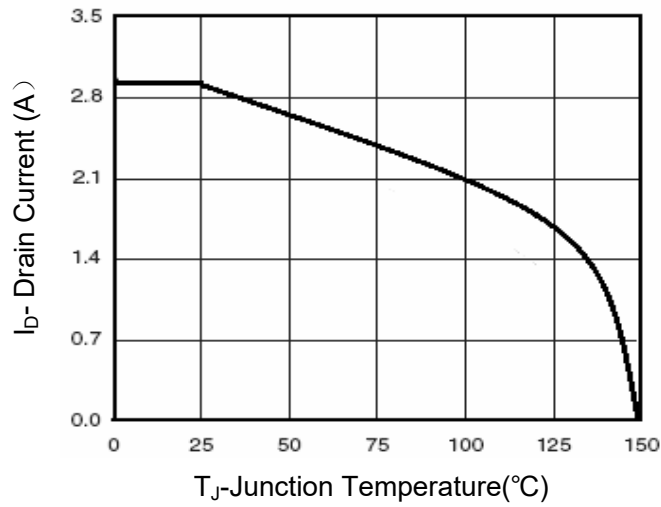

**Figure 1 Drain Current**

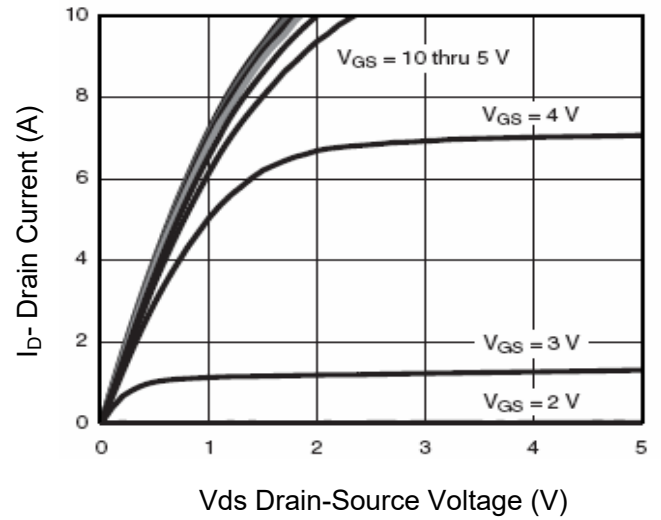

**Figure 2 Output Characteristics**

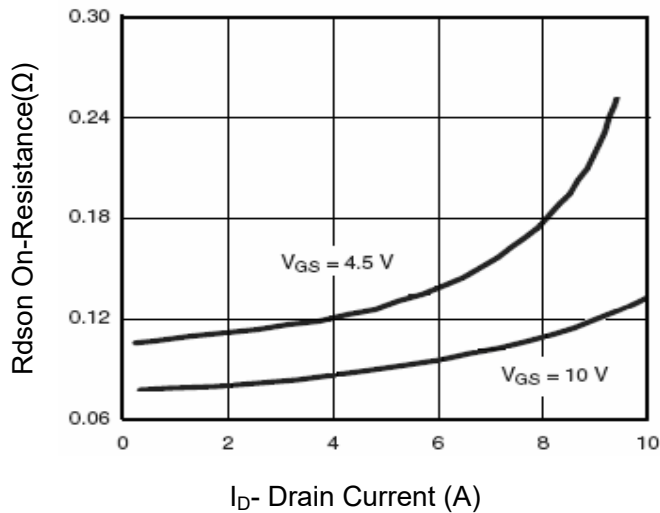

**Figure 3 Drain-Source On-Resistance**

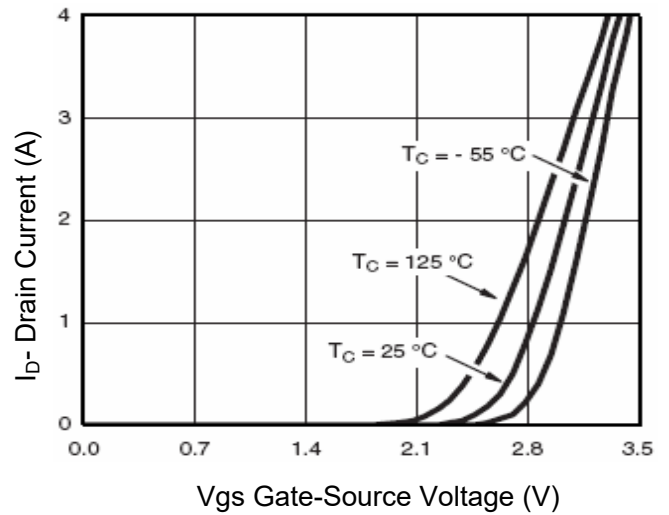

**Figure 4 Transfer Characteristics**

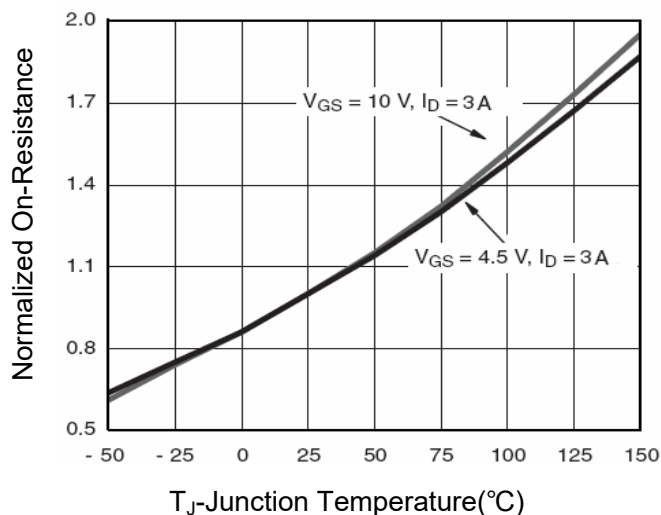

**Figure 5 Drain-Source On-Resistance**

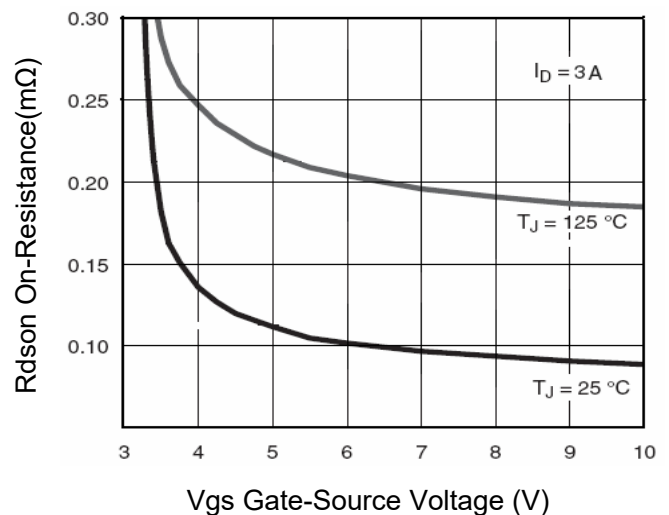

**Figure 6  $R_{DS(on)}$  vs  $V_{GS}$**

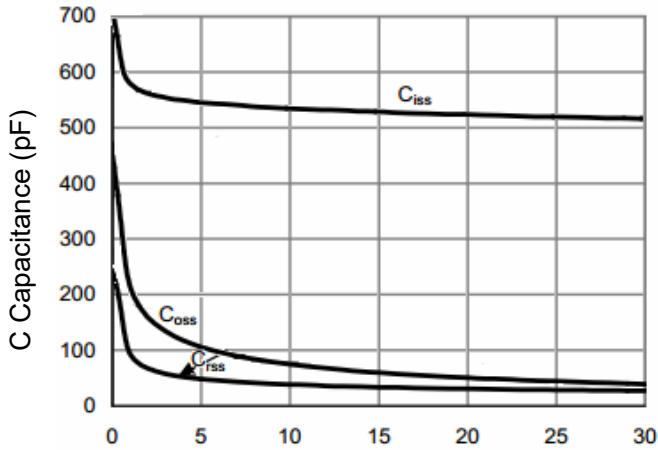
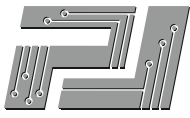

Figure 7 Capacitance vs Vds

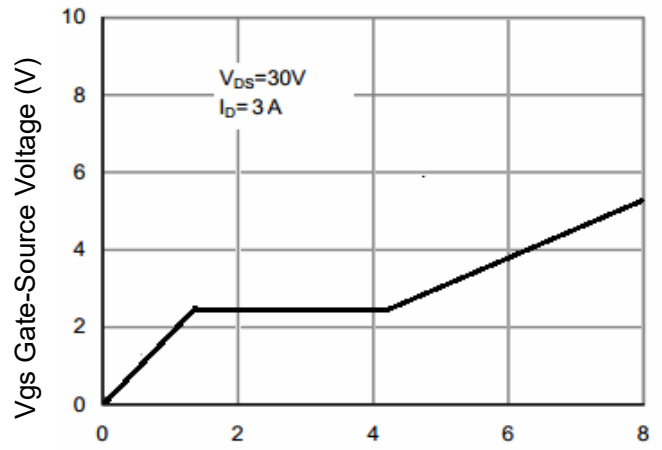

Figure 8 Gate Charge

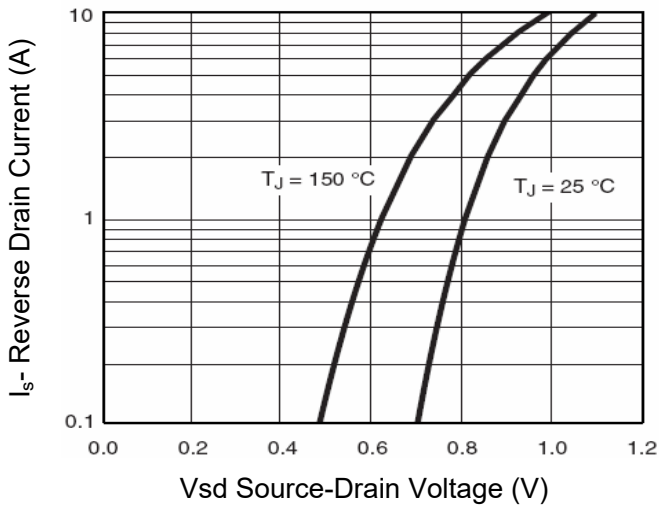

Figure 9 Source- Drain Diode Forward

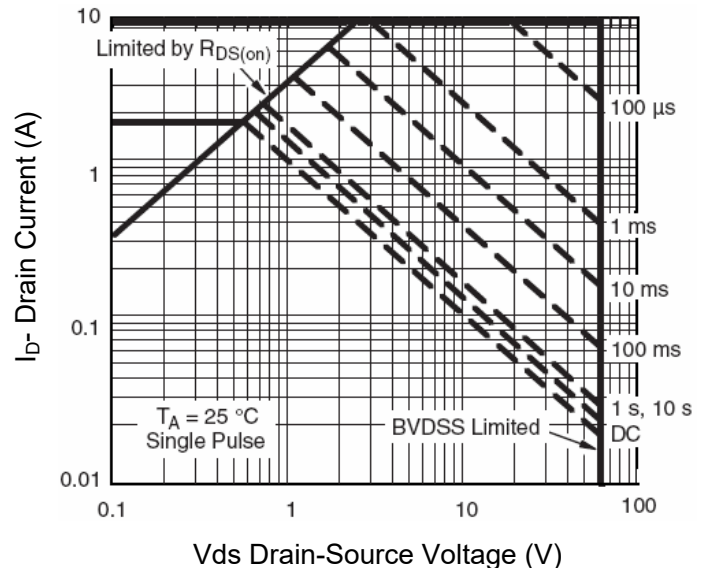

Figure 10 Safe Operation Area

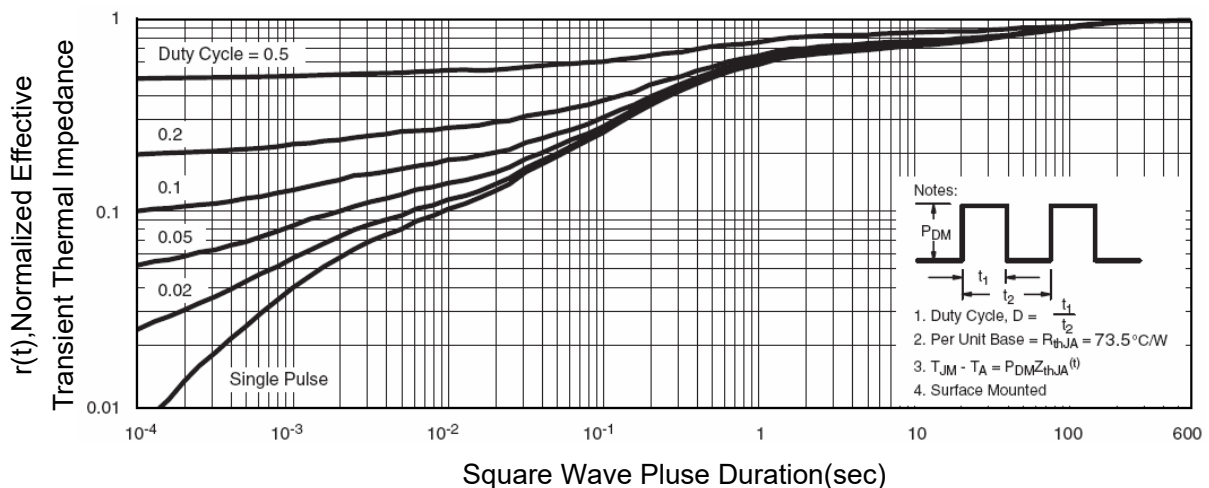

Figure 11 Normalized Maximum Transient Thermal Impedance



# PJM02B60SA

## N- Enhancement Mode Field Effect Transistor

### Package Outline

### SOT-23

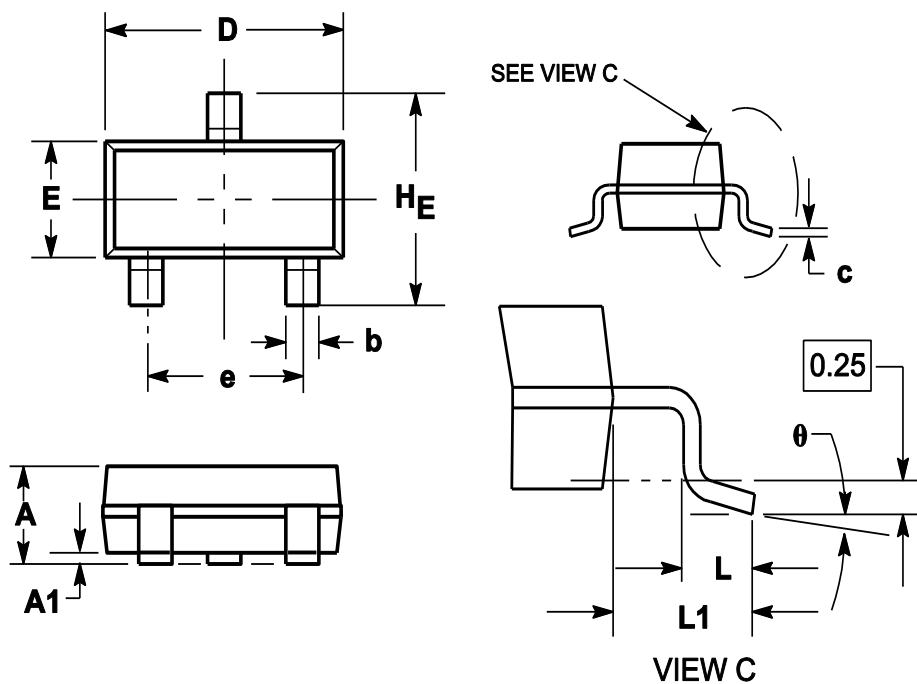

Symbol	Dimensions in millimeter		
	Min.	Typ.	Max.
A	0.900	1.025	1.150
A1	0.000	0.050	0.100
b	0.300	0.400	0.500
c	0.080	0.115	0.150
D	2.800	2.900	3.000
E	1.200	1.300	1.400
HE	2.250	2.400	2.550
e	1.800	1.900	2.000
L1	0.550REF		
L	0.300		0.500
θ	0°		8°

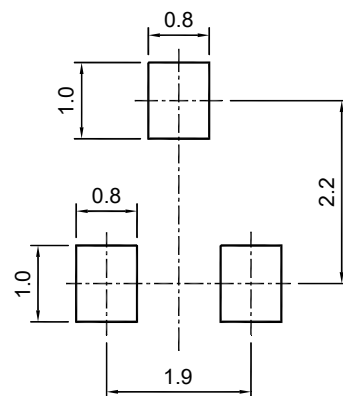

SOT-23

**Recommended soldering pad**

### Ordering Information

Device	Package	Shipping
PJM02N60SA	SOT-23	3000/Reel&Tape(7inch)



### Conditions of Soldering and Storage

#### ◆ Recommended condition of reflow soldering

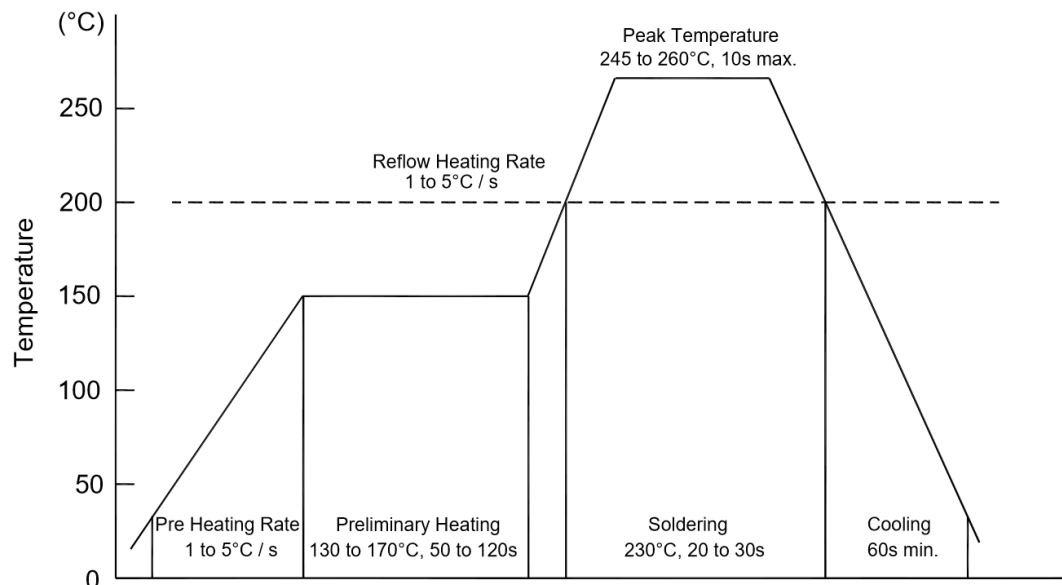

Recommended peak temperature is over 245 °C. If peak temperature is below 245 °C, you may adjust the following parameters:

- Time length of peak temperature (longer)
- Time length of soldering (longer)
- Thickness of solder paste (thicker)

#### ◆ Conditions of hand soldering

- Temperature: 370 °C
- Time: 3s max.
- Times: one time

#### ◆ Storage conditions

- **Temperature**  
5 to 40 °C
- **Humidity**  
30 to 80% RH
- **Recommended period**  
One year after manufacturing



### Package Specifications

#### ◆ The method of packaging

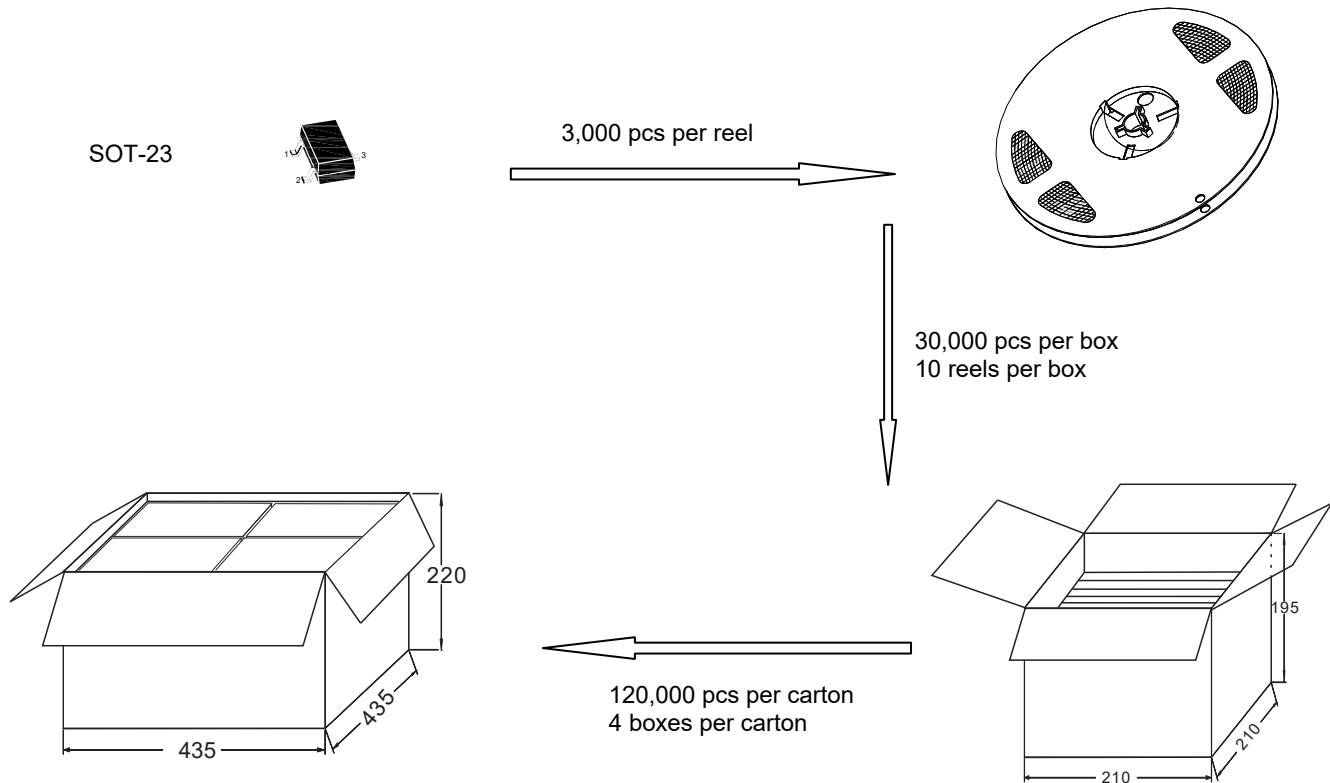

#### ◆ Embossed tape and reel data

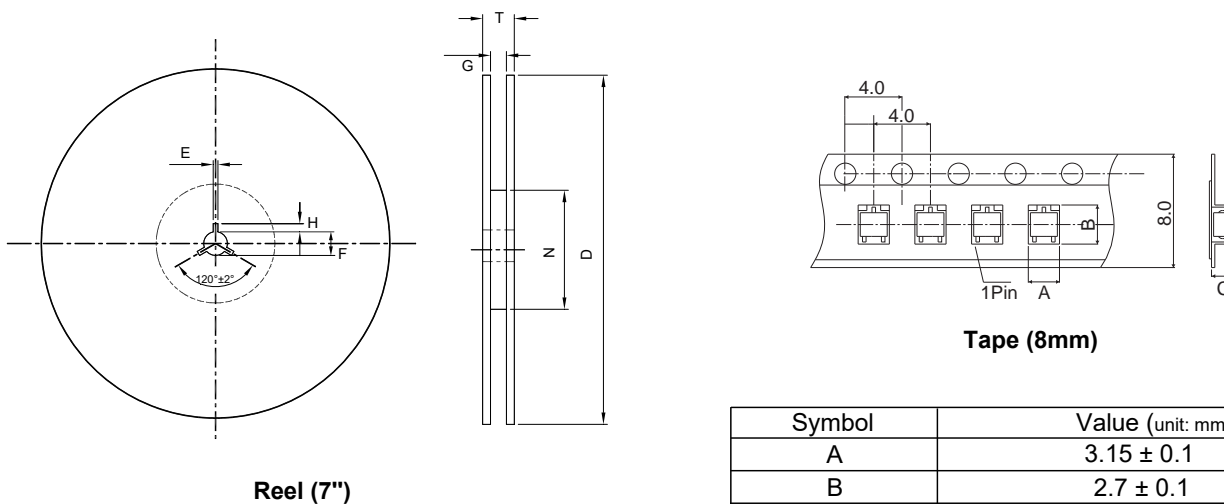

Symbol	Value (unit: mm)
A	3.15 ± 0.1
B	2.7 ± 0.1
C	1.25 ± 0.1
E	2 ± 0.5
F	13 ± 0.5
D	178 ± 2.0
G	8.4 ± 1.5
H	4 ± 0.5
N	60
T	< 14.9

单击下面可查看定价，库存，交付和生命周期等信息

[>>PJSEMI\(平晶微\)](#)