



# PJM6801DPSG

## Dual P-Channel Enhancement Mode Power MOSFET

### Features

- Excellent  $R_{DS(on)}$  and low gate charge
- $V_{DS} = -30V, I_D = -4.1A$   
 $R_{DS(on)} < 60m\Omega @ V_{GS} = -10V$

### SOT-23-6

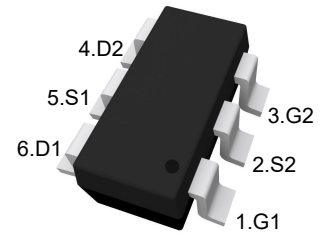

Marking Code: 6801

### Applications

- Load switch
- PWM application

### Schematic Diagram

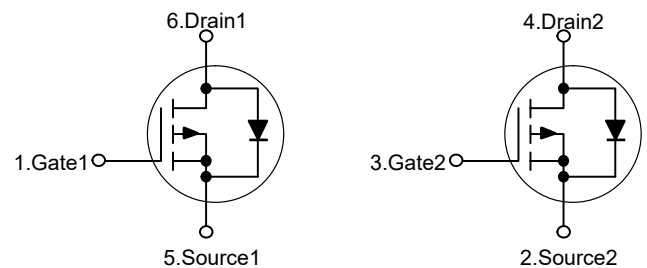

### Absolute Maximum Ratings

Ratings at 25°C ambient temperature unless otherwise specified.

Parameter	Symbol	Value	Unit
Drain-Source Voltage	$-V_{DS}$	30	V
Gate-Source Voltage	$V_{GS}$	$\pm 12$	V
Drain Current-Continuous	$-I_D$	4.1	A
Drain Current-Pulsed <sup>Note1</sup>	$-I_{DM}$	30	A
Maximum Power Dissipation	$P_D$	1.4	W
Junction Temperature	$T_J$	150	°C
Storage Temperature Range	$T_{STG}$	-55 to +150	°C

### Thermal Characteristics

Thermal Resistance, Junction-to-Ambient <sup>Note2</sup>	$R_{\theta JA}$	89	°C/W
--	-----------------	----	------



# PJM6801DPSG

## Dual P-Channel Enhancement Mode Power MOSFET

### Electrical Characteristics

(Ta=25°C unless otherwise specified)

Parameter	Symbol	Test Condition	Min.	Typ.	Max.	Unit
<b>Static Characteristics</b>						
Drain-Source Breakdown Voltage	$-V_{(BR)DSS}$	$V_{GS}=0V, I_D=-250\mu A$	30	--	--	V
Zero Gate Voltage Drain Current	$-I_{DSS}$	$V_{DS}=-30V, V_{GS}=0V$	--	--	1	$\mu A$
Gate-Body Leakage Current	$I_{GSS}$	$V_{GS}=\pm 12V, V_{DS}=0V$	--	--	$\pm 100$	nA
Gate Threshold Voltage <sup>Note3</sup>	$-V_{GS(th)}$	$V_{DS}=V_{GS}, I_D=-250\mu A$	0.6	1	1.4	V
Drain-Source On-Resistance <sup>Note3</sup>	$R_{DS(on)}$	$V_{GS}=-10V, I_D=-3A$	--	45	60	m $\Omega$
		$V_{GS}=-4.5V, I_D=-2A$	--	55	80	m $\Omega$
Forward Transconductance <sup>Note3</sup>	$g_{FS}$	$V_{DS}=-5V, I_D=-4A$	--	10	--	S
<b>Dynamic Characteristics</b>						
Input Capacitance	$C_{iss}$	$V_{DS}=-15V, V_{GS}=0V, f=1MHz$	--	880	--	pF
Output Capacitance	$C_{oss}$		--	105	--	pF
Reverse Transfer Capacitance	$C_{rss}$		--	65	--	pF
<b>Switching Characteristics</b>						
Turn-on Delay Time	$t_{d(on)}$	$V_{DD}=-15V, I_D=-4.1A$ $V_{GS}=-10V, R_{GEN}=6\Omega$	--	7	--	nS
Turn-on Rise Time	$t_r$		--	3	--	nS
Turn-off Delay Time	$t_{d(off)}$		--	30	--	nS
Turn-off Fall Time	$t_f$		--	12	--	nS
Total Gate Charge	$Q_g$	$V_{DS}=-15V, I_D=-4.1A,$ $V_{GS}=-4.5V$	--	8.5	--	nC
Gate-Source Charge	$Q_{gs}$		--	1.8	--	nC
Gate-Drain Charge	$Q_{gd}$		--	2.7	--	nC
<b>Source-Drain Diode Characteristics</b>						
Diode Forward Voltage <sup>Note3</sup>	$-V_{SD}$	$V_{GS}=0V, I_S=-4.1A$	--	--	1.2	V
Diode Forward Current <sup>Note2</sup>	$-I_S$		--	--	4.1	A

- Note: 1. Repetitive Rating: Pulse width limited by maximum junction temperature.  
 2. Surface Mounted on FR4 Board,  $t \leq 10$  sec.  
 3. Pulse Test: Pulse width  $\leq 300\mu s$ , duty cycle  $\leq 2\%$ .



### Typical Characteristic Curves

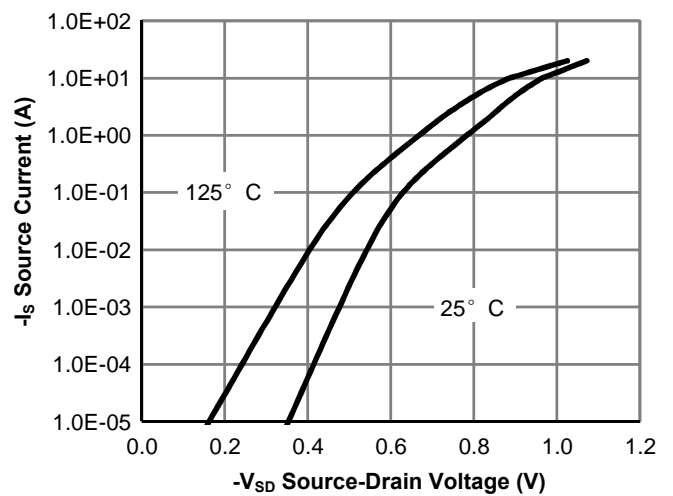
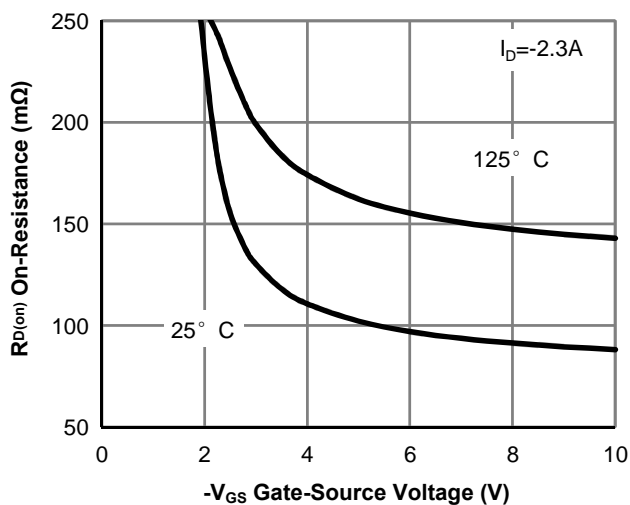
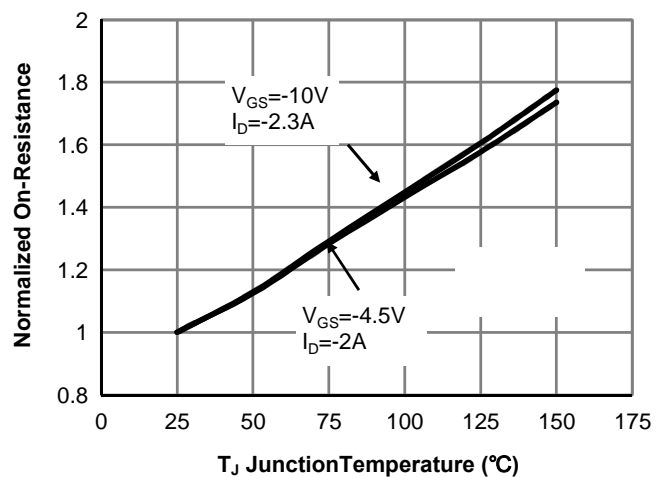
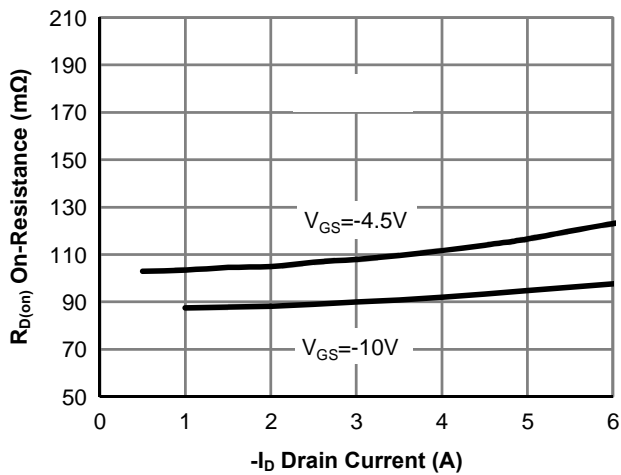
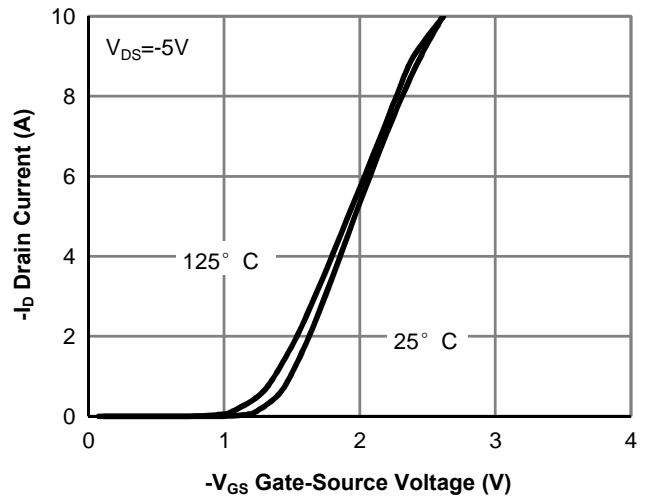
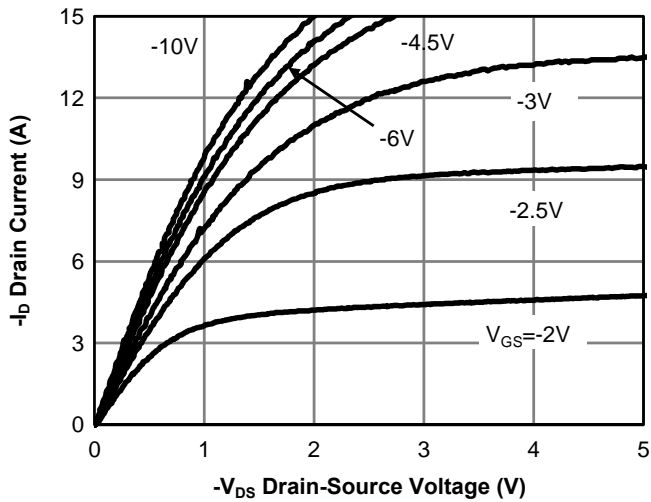



# PJM6801DPSG

## Dual P-Channel Enhancement Mode Power MOSFET

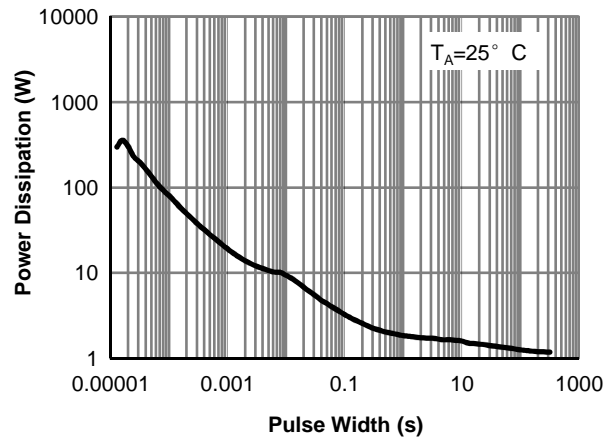
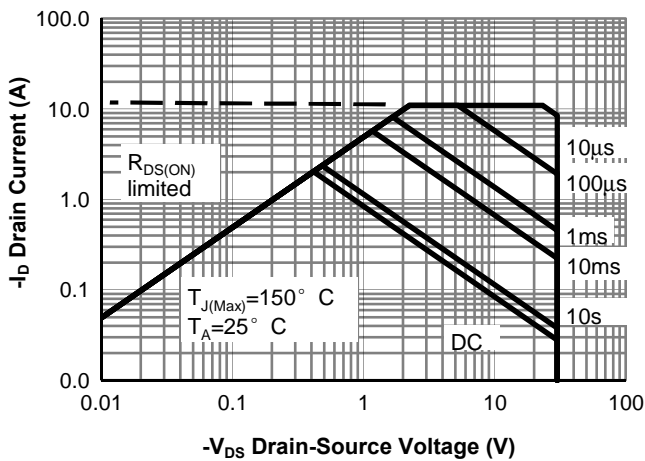
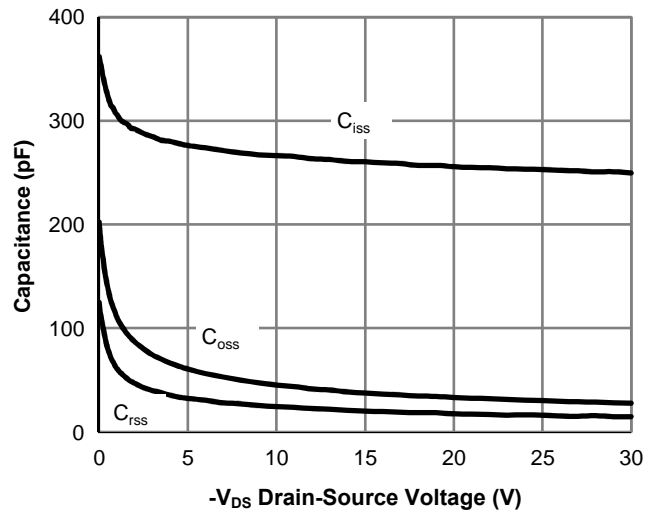
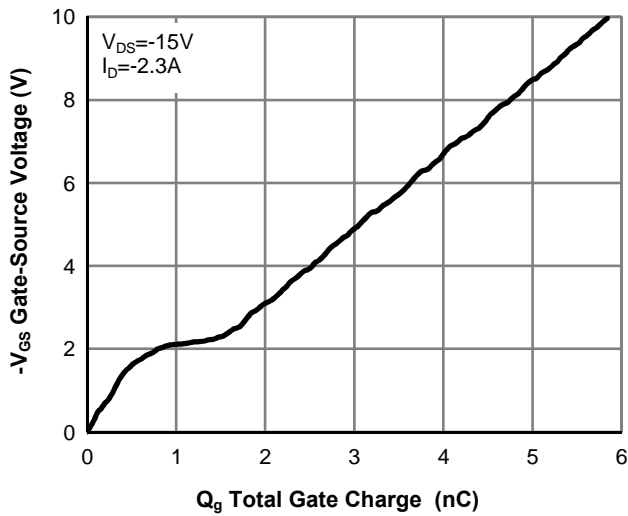



# PJM6801DPSG

## Dual P-Channel Enhancement Mode Power MOSFET

### Package Outline

SOT-23-6

Dimensions in mm

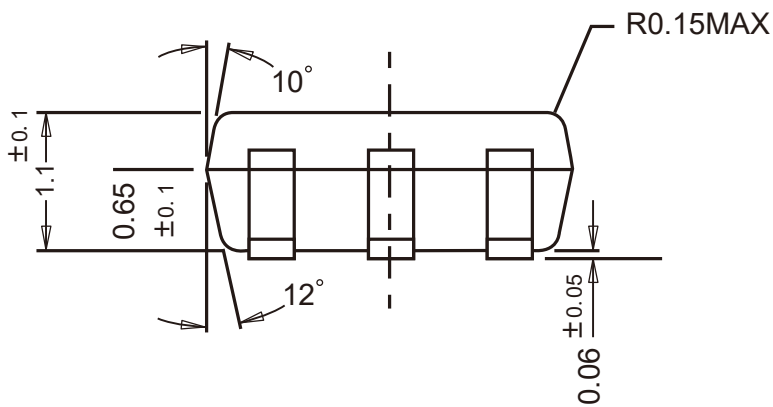
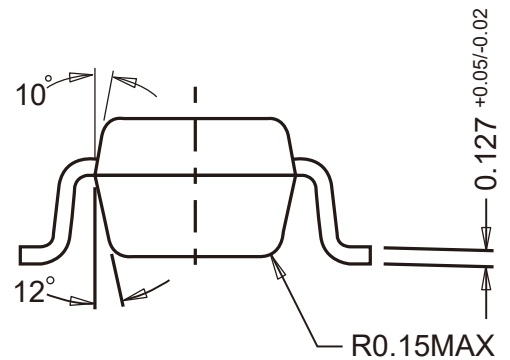
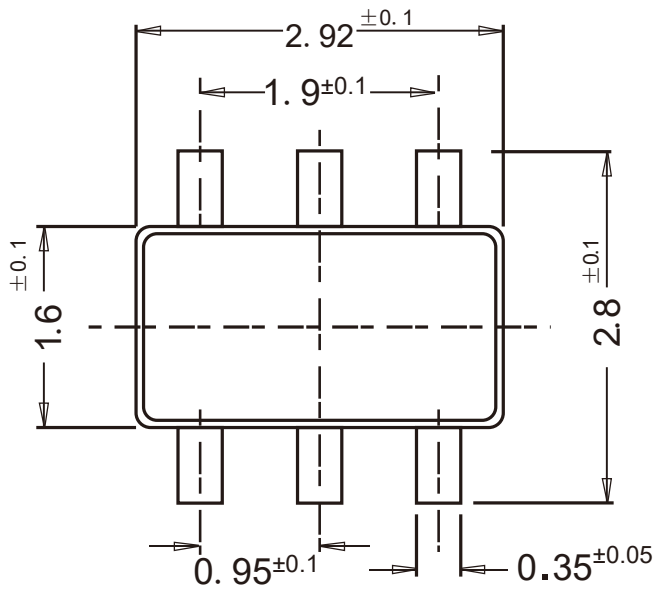

### Ordering Information

Device	Package	Shipping
PJM6801DPSG	SOT-23-6	3,000PCS/Reel&7inches



### Conditions of Soldering and Storage

#### ◆ Recommended condition of reflow soldering

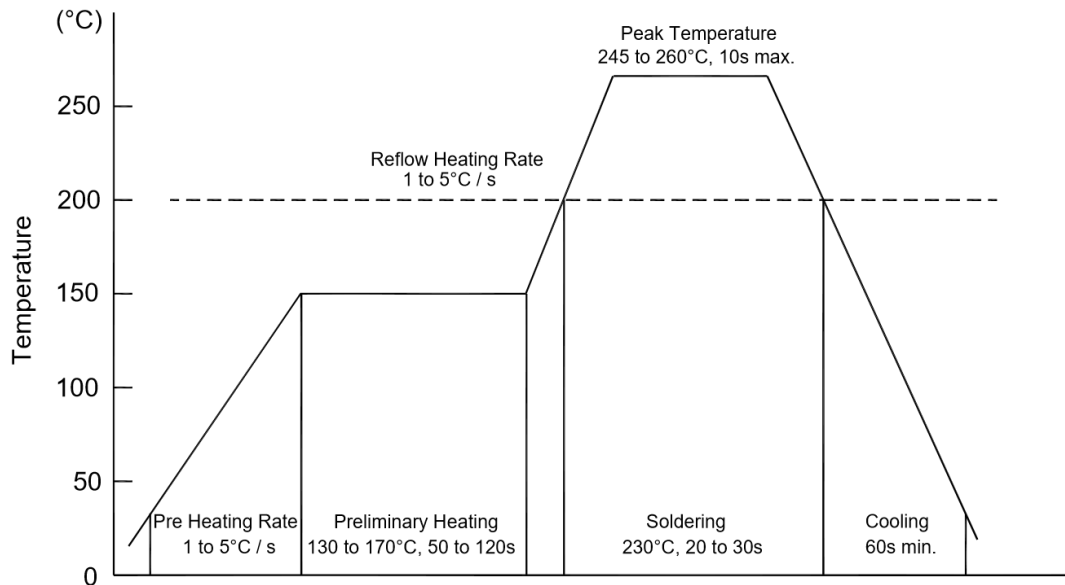

Recommended peak temperature is over 245 °C. If peak temperature is below 245 °C, you may adjust the following parameters:

- Time length of peak temperature (longer)
- Time length of soldering (longer)
- Thickness of solder paste (thicker)

#### ◆ Conditions of hand soldering

- Temperature: 370 °C
- Time: 3s max.
- Times: one time

#### ◆ Storage conditions

- **Temperature**  
5 to 40 °C
- **Humidity**  
30 to 80% RH
- **Recommended period**  
One year after manufacturing



# PJM6801DPSG

## Dual P-Channel Enhancement Mode Power MOSFET

### Package Specifications

- The method of packaging

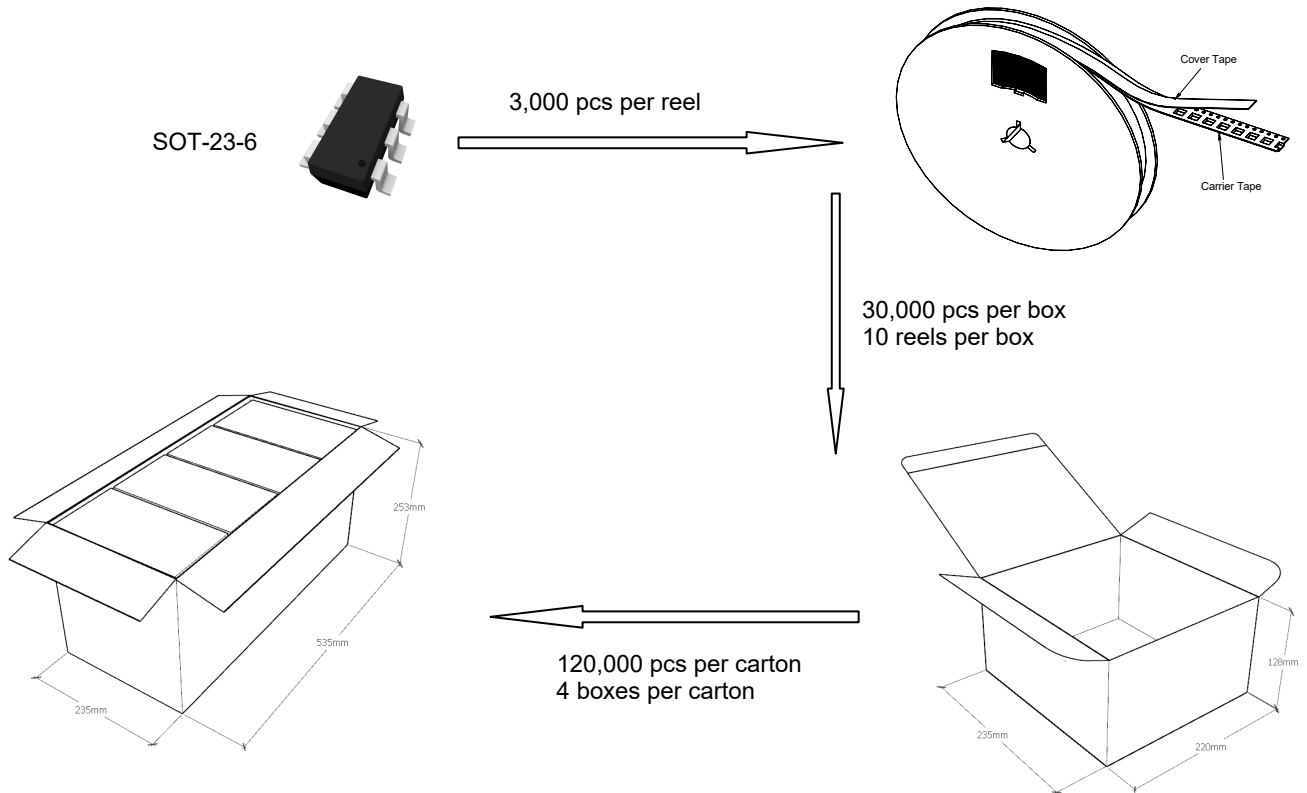

### ◆ Embossed tape and reel data

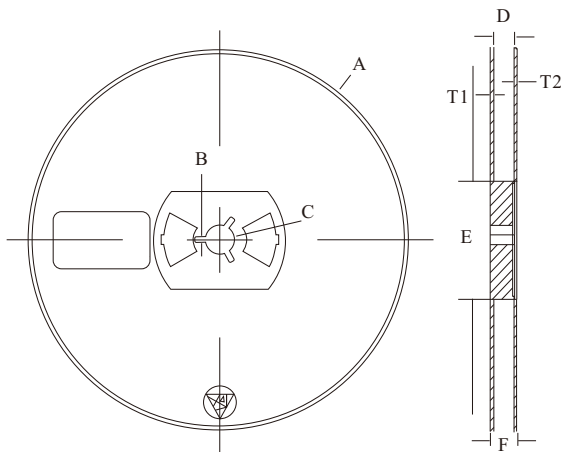

Symbol	Value (unit: mm)
A	$\varnothing 177.8 \pm 1$
B	$2.7 \pm 0.2$
C	$\varnothing 13.5 \pm 0.2$
E	$\varnothing 54.5 \pm 0.2$
F	$12.3 \pm 0.3$
D	$9.6 + 2 / - 0.3$
T1	$1.0 \pm 0.2$
T2	$1.2 \pm 0.2$

### Reel (7")

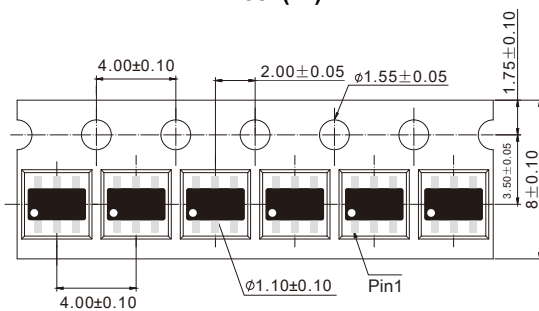

### Tape (8mm)

单击下面可查看定价，库存，交付和生命周期等信息

[>>PJSEMI\(平晶微\)](#)