

Fast Acting | 0.126x0.064 inch Thick Film Chip Fuses

1206HV Series

1206HV Series are the fuses set the industry standard for performance, reliability and quality. The solder-free design provides excellent on-off and temperature cycling characteristics during use and also makes our SMD fuses more heat and shock tolerant than typical subminiature fuses.



Features

- Compatible with reflow and wave solder
- Lead Free and Halogen free material
- Rapid interruption of excessive current
- Excellent environmental integrity
- One time positive disconnect
- AEC-Q200 Automotive Grade Certified

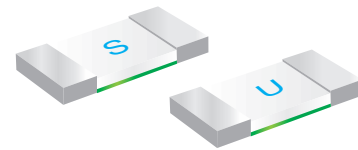

Applications

- Flat panel displays and televisions
- Automotive infotainment and ECU
- Computer servers
- Portable electronics
- Mobile device chargers
- Power Battery Packs

Electrical Characteristics

Amp Rating	% of Amp Rating	Opening Time
0.25~5A	100%	4 Hours Min.
	250%	5 Seconds Max.
6~20A	350%	5 Seconds Max.

Specification

Part Number	Ampere Rating (A)	Voltage Rating (V)	Interrupting Rating	Typical Cold Resistance (Ohms)	Typical Melting I ² t (A ² Sec)	Typical Voltage Drop (V)	Marking Code
1206HV-R250	0.250	125Vac/dc	50A	3.608	0.00012	1.407	0.25
1206HV-R375	0.375	125Vac/dc	50A	1.882	0.0003	0.718	E
1206HV-R500	0.500	125Vac/dc	50A	1.028	0.0005	0.650	0.5
1206HV-R750	0.750	125Vac/dc	50A	0.850	0.009	1.000	0.75
1206HV-1A	1.00	125Vac/dc	50A	0.240	0.0075	0.300	H
1206HV-1.25A	1.25	125Vac/dc	50A	0.175	0.009	0.290	-
1206HV-1.5A	1.50	125Vac/dc	50A	0.125	0.013	0.250	1.5
1206HV-2A	2.00	125Vdc	50A	0.080	0.04	0.200	N
1206HV-2.5A	2.50	125Vdc	50A	0.038	0.045	0.140	2.5
1206HV-3A	3.00	125Vdc	50A	0.032	0.065	0.130	P
1206HV-3.5A	3.50	72Vdc	50A	0.025	0.08	0.120	3.5
1206HV-4A	4.00	72Vdc	50A	0.020	0.11	0.110	S
1206HV-5A	5.00	72Vdc	50A	0.013	0.185	0.100	T
1206HV-6A	6.00	63Vdc/72Vdc	50A	0.0155	8	0.140	F
1206HV-7A	7.00	63Vdc/72Vdc	50A	0.0115	10	0.130	7
1206HV-8A	8.00	32Vdc/48Vdc	150A	0.0076	12	0.123	V
1206HV-10A	10.0	32Vdc/48Vdc	150A	0.0055	18	0.110	U
1206HV-12A	12.0	32Vdc/48Vdc	150A	0.0050	11.5	0.085	12
1206HV-15A	15.0	32Vdc/48Vdc	150A	0.0034	16.5	0.078	15
1206HV-20A	20.0	32Vdc/48Vdc	150A	0.0022	40	0.080	Q

• AC Interrupting Rating (measured at designated voltage, 100% power factor); DC Interrupting Rating (measured at designated voltage, time constant of less than 50 microseconds, battery source)
 • DC Cold Resistance are measured at <10% of rated current in ambient temperature of 25°C Typical
 • Pre-arcing I²t are measured at 10In Current
Specifications are subject to change without notice. Application testing is strongly recommended.

Fast Acting | 0.126x0.064 inch

Thick Film Chip Fuses

1206HV Series

Dimension

Unit: mm/inch

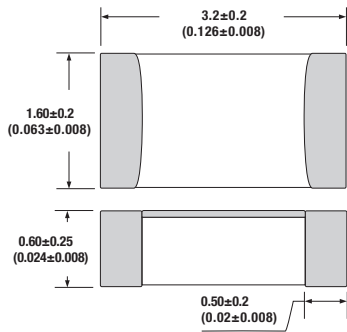

Pad layout

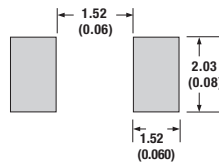

Packaging

- Quantity: 3,000pcs
- 8mm wide tape on 178mm(7 inch) diameter reel -specification EIA Standard 481.

Soldering Parameters

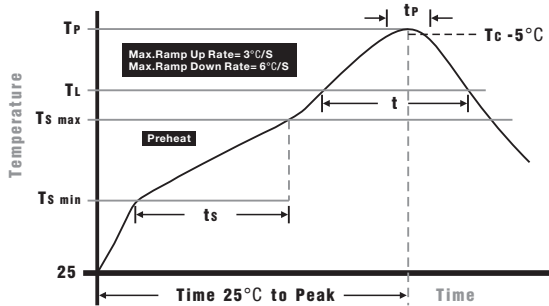

Wave Soldering: 260°C, 10 seconds max.
Infrared Reflow: 260°C, 30 seconds max.

IR Reflow Profile

Preheat Heat	
Temperature min (T _{smin})	150°C
Temperature max (T _{smax})	200°C
Time (T _{smin} to T _{smax}) (t _s)	60 -120 seconds
Average ramp-up rate (T _{smax} to T _p)	3°C/second max.
Liquidous temperature (T _l)	217°C
Time at liquidous (t _l)	60 - 150 seconds
Peak temperature(T _p)	260+0/-5°C
Time within 5°C of actual peak Temperature (t _p)	10 - 30 seconds
Average ramp-down rate (T _p to T _{smax})	6°C/second max.
Time 25 °C to peak temperature	8 minutes max.

Temperature Derating Curve

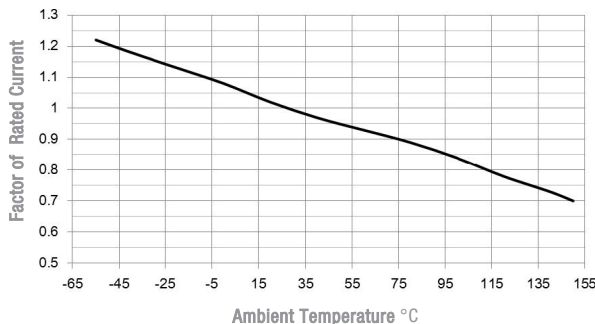

- Normal ambient temperature: 23+/-3 C
- Operating temperature: -55 ~ 150 C, with proper correction factor applied

Fast Acting | 0.126x0.064 inch

Thick Film Chip Fuses

1206HV Series

Average Time Current Curves

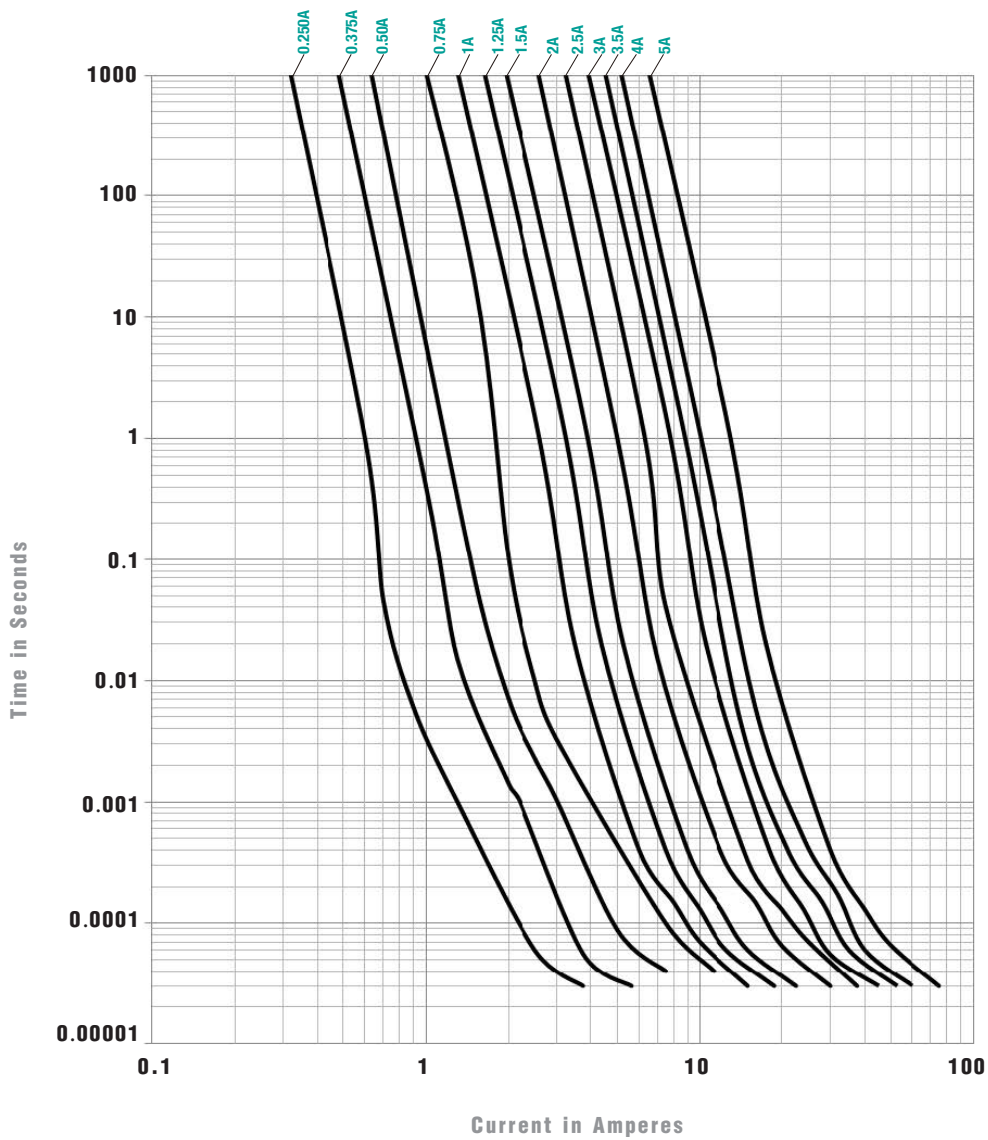

Fast Acting | 0.126x0.064 inch

Thick Film Chip Fuses

1206HV Series

Average Time Current Curves

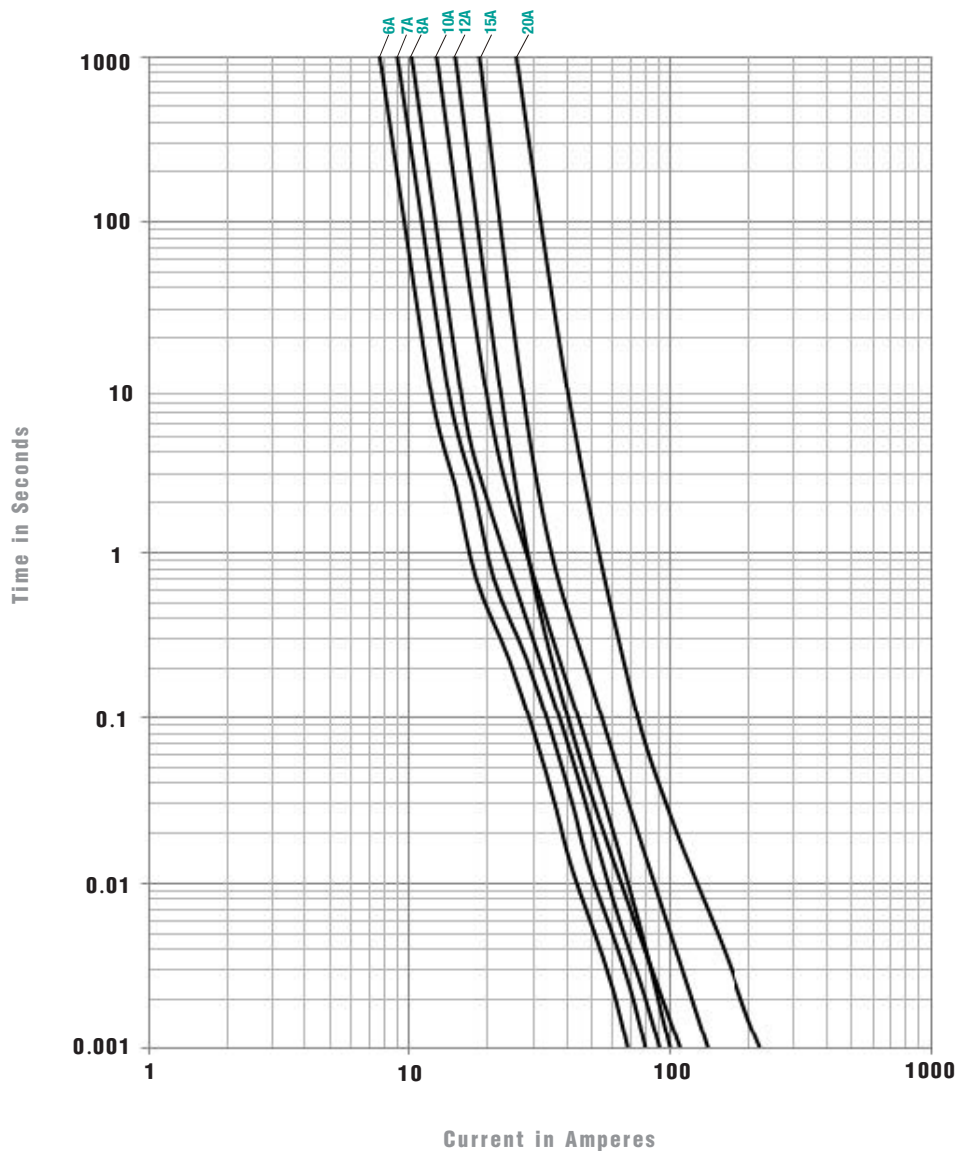

© 2021 PROSEMI Inc. All Rights Reserved. Specifications and features are subject to change without notice. www.prosemitech.com

The PROSEMI logo, and all other PROSEMI trademarks are the property of PROSEMI Inc. All other trademarks are the property of their respective owners.

单击下面可查看定价，库存，交付和生命周期等信息

[>>Prosemi \(普森美\)](#)

[>>点击查看相关商品](#)