

A1RFRD10

REVISION RECORD				
REV	ECO	DESCRIPTION	DRFT	CHKD

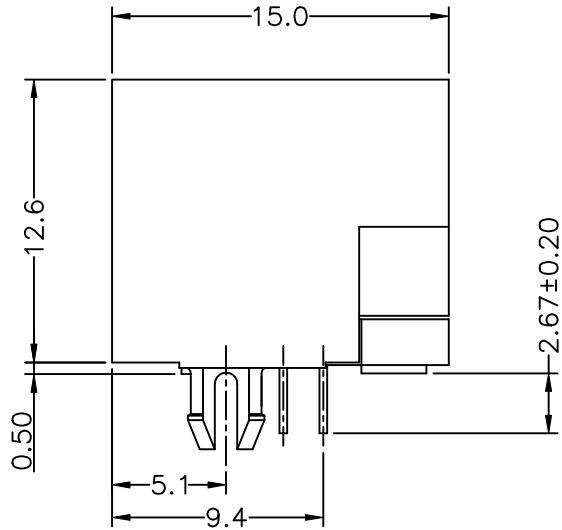
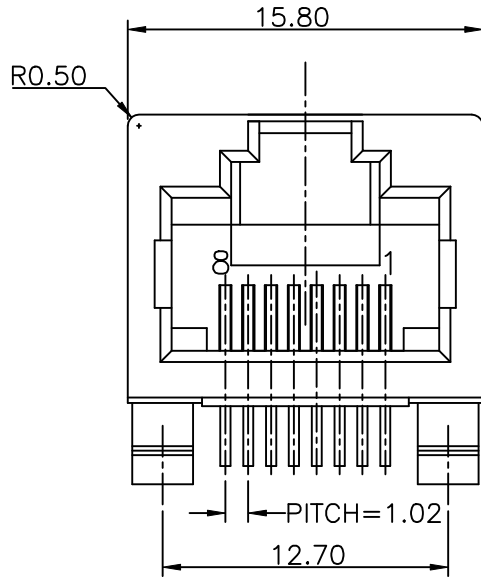

**NOTES:**  
**ELECTRICAL:**

- VOLTAGE RATING : 125 VAC RMS.
- CURRENT RATING : 1.5 AMP.
- CONTACT RESISTANCE : 30 MILLIOHMS MAX.
- INSULATION RESISTANCE: 1000 MEGOHMS MIN @ 500 VDC.
- DIELECTRIC STRENGTH : 1000 VAC RMS 60Hz, 1MIN.
- OPERATING: 750 CYCLES MIN.

**MECHANICAL:**

- HOUSING MATERIAL : FR52 UL94V-0. COLOR-BLACK.
- INSERT MATERIAL : FR52 UL94V-0. COLOR-BLACK.
- CONTACT MATERIAL : PHOSPHOR BRONZE 0.35mm THICKNESS.
- PLATING : GOLD PLATING OVER NICKEL.
- PCB RETENTION PRE-SOLDER : 1 LB MIN.
- PCB RETENTION POST-SOLDER: 10 LBS MIN.

**ENVIRONMENTAL:**

- STORAGE : -40°C TO +85°C.
- OPERATION: 0°C TO 70°C.
- WAVE SOLDERING TEMPERATURE: 255~265°(5~10 SECONDS)  
MATES WITH MODULAR PLUG CONFORMING TO  
FCC PART 68, SUBPART F.

PART NUMBER: E 5J 8 8 - 0 0 L J G X-L

00-W/O SHIELD&LED  
JG-W/O LOGO FR52 STAMPED PIN

PLATING: 1-3u" 4-30u"  
2-6u" 5-50u"  
3-15u"

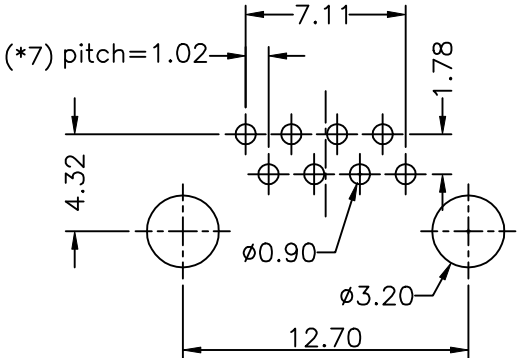

PC Board Thickness=1.60mm  
PC Board Layout Component Side Shown

DETACHED LISTS	MM (INCH)	DFTO PETERS	DATE 03/30/05	FULL RISE ELECTRONIC CO., LTD	
	TOLERANCES EXCEPT AS NOTED	CHKD JAKE	DATE 2005/3/31		
		MFO	DATE		
		APPV LUSHENG	DATE 2005/3/31		
	MM			TITLE	
.0 ± 0.20	±			LED JACK UTP W/O LED	
.00 ± 0.15	±			DRAWING NO. GE5J3A16-LA	SIZE REV
.000 ± 0.075	±			/PART NO. SEE NOTE	A3 0
ANGLES ±	MATERIAL :		QTY :		DO NOT SCALE DRAWING
	FINISH :		SCALE : 4:1		SHEET 1 OF 1
THIRD ANGLE PROJECTION					

单击下面可查看定价，库存，交付和生命周期等信息

[>>Pulse\(普思\)](#)