

NOTES:

1. THIS COMPONENT CONFORMS TO UL60950. UL FILE NO. IS: E216117.

	WARNING: THIS COMPONENT IS RECOGNIZED BY ONE OR MORE SAFETY AGENCIES SUCH AS UL, VDE, CSA AND/OR TUV. ALL ENGINEERING CHANGES MUST HAVE PRIOR APPROVAL BY THE DESIGN CENTER PRODUCT SAFETY DEPARTMENT FOR SAFETY AGENCY COMPLIANCE.	ECH APPROVAL: QA APPROVAL: DATE:

2. ROHS COMPLIANT

3. MATERIAL

- 3.1 PLASTIC HOUSING: THERMOPLASTIC, BLACK WITH FLAMMABILITY RATING UL 94V-0 OR BETTER.
- 3.2 CONTACTS BASE MATERIAL: PHOSPHOR BRONZE
- 3.3 UNDER PLATING: 50 μINCHES NICKEL MINIMUM.
- 3.4 CONTACTS PLATING: 30 MICROINCHES GOLD PLATING.
- 3.5 SOLDER TAIL PLATING : 200~500 μINCHES 100% TIN, MATTE FINISH.
- 3.6 METAL SHIELD: STAINLESS STEEL. (FRONT SHIELD)
METAL SHIELD: NICKEL PLATING ON COPPER ALLOY.(REAR SHIELD)
- 3.7 SHIELD PIN: SOLDER WITH TIN

4. ELECTRICAL CHARACTERISTICS:

- 4.1 INSULATION RESISTANCE: 500 MEGAOHMS MINIMUM

5. MECHANICAL

- 5.1 DURABILITY (MATING/UNMATING): 750 CYCLES.
- 5.2 CONTACT RESISTANCE: INTIAL 30 mOHMS Max, CHANGE 20 mOHMS

6. JACK CAVITY CONFORMS TO FCC PART 68 SUBPART F.

7. PCB PLATING: HASL (TOP PCB), ENIG (BOTTOM PCB)

8. STORAGE TEMPERATURE: -20°C TO +125°C

9. COMPLIANCE TO J-STD:

- A. J-STD-002: SOLDERABILITY AT 245°C DIP AND LOOK TEST
- B. J-STD-020: LEVEL 1, NO MOISTURE SENSITIVE
- C. J-STD-075: W2, 270°C MAXIMUM THROUGH WAVE SOLDER

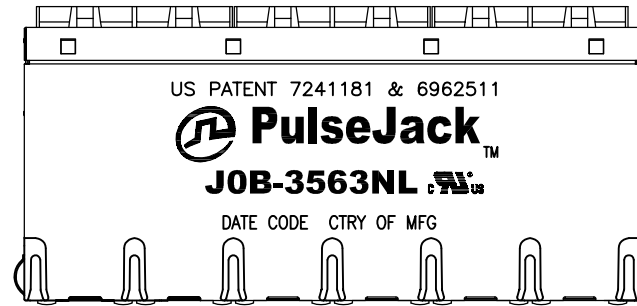

GREEN LED

YELLOW LED

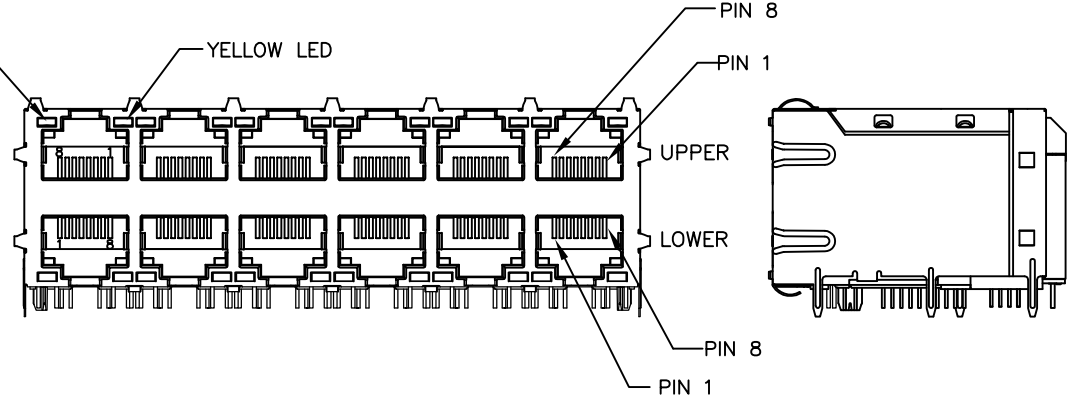

FINAL OUTLINE

UPPER PORT PINS

LOWER PORT PINS

LOWER PORT PINS ENLARGED CUT-OUT VIEW

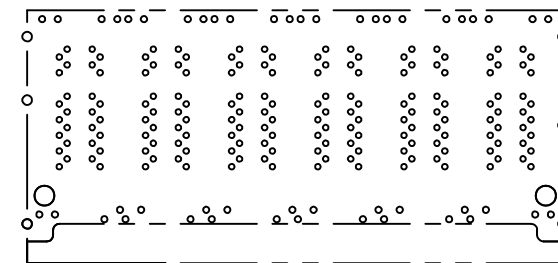
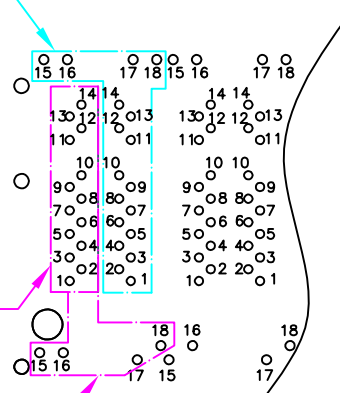

PIN ASSIGNMENT (COMPONENT SIDE VIEW)

© Copyright, 2017. Pulse Electronics Corp. All rights reserved. Pulse confidential & proprietary. (04/24/17)

PRODUCT DESCRIPTION	TLA DRAWING	PS DRAWING	SHEET	PART NO.	DATASHEET REV.
CONN,RJ45,2X6,1GPP,1:1,TY	JOB-3563NL-10	PS-2417.611-A	1 OF 4	JOB-3563NL	J

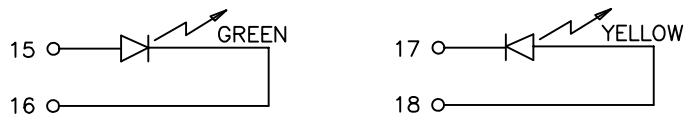
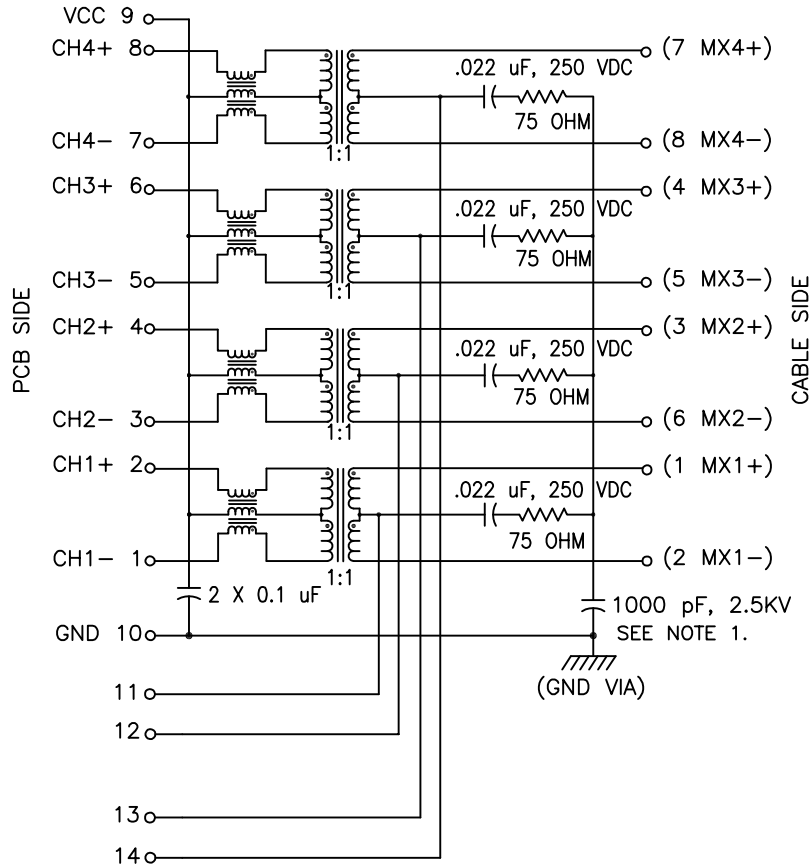

SCHEMATIC

NOTE 1: HIGH-VOLTAGE CAPACITOR IS COMMON FOR UPPER AND LOWER PORTS.

ELECTRICAL CHARACTERISTICS AT +25°C UNLESS OTHER SPECIFIED
MEETS IEEE 802.3 SPECIFICATION

PARAMETER	SPECIFICATIONS		
OPERATING TEMP	0°C TO +70 °C		
URNS RATIO	1 : 1 ±2%		
POLARITY	PER SCHEMATIC		
INSERTION LOSS	100 KHz	1-100 MHz	125 MHz
	-1.2 dB MAX	-0.2-0.002*f ^{1.4} dB MAX	-3.0 dB MAX
RETURN LOSS (Z OUT = 100 OHM ±15%)	.1-40 MHz	40-100 MHz	
	-16 dB MIN	-10+20*LOG ₁₀ (f/80 MHz) dB MIN	
INDUCTANCE (OCL) AT 100 KHz, 100 mV (MEDIA SIDE, 0°C~70°C)	WITH 0 mA DC BIAS		WITH 20.5 mA DC BIAS
	180 uH MIN		150 uH MIN
CROSSTALK, ADJACENT CHANNELS	1 MHz	10-100 MHz	
	-50 dB MIN	-52+22*LOG ₁₀ (f/10) dB MIN	
COMMON MODE REJECTION RATIO	2 MHz	30-200 MHz	
	-50 dB MIN	-15+20*LOG ₁₀ (f/200) dB MIN	
DC RESISTANCE, 1/2 WINDING	.65 OHMS MAX		
DC RESISTANCE IMBALANCE	±.065 OHMS MAX (CENTER TAP SYMMETRY)		
DC CURRENT/VOLTAGE RATING - PSE PINS	1.37A MAX, @ 57 V (CONTINUOUS)		
INPUT - OUTPUT ISOLATION	2250 VDC MINIMUM FOR 60 SECONDS		

NOTE: f IS FREQUENCY IN MHz.

EMMITTED COLOR	GREEN	YELLOW
WAVELENGTH (nm)	570 nm	587 nm
BRIGHTNESS (mCD)	8 TYP. AT 20 mA	6.5 TYP. AT 20 mA
VIEWING ANGLE	100°	100°
POWER DISSIPATION (Pd)	80 mW MAX	80 mW MAX
FORWARD VOLTAGE (Vf)	2.0 TO 2.6 V (UPPER PORT)	2.1 TO 2.6 V (UPPER PORT)
	2.2 TO 2.8 V (LOWER PORT)	2.15 TO 2.8 V (LOWER PORT)
REVERSE VOLTAGE (Vr)	5.0 V MAX	5.0 V MAX

NOTE: PER VENDOR'S SPECIFICATIONS

© Copyright, 2017. Pulse Electronics Corp. All rights reserved. Pulse confidential & proprietary. (04/24/17)

PRODUCT DESCRIPTION	TLA DRAWING	PS DRAWING	SHEET	PART NO.	DATASHEET REV.
CONN,RJ45,2X6,1GPP,1:1,TY	JOB-3563NL-10	PS-2417.611-A	2 OF 4	JOB-3563NL	J

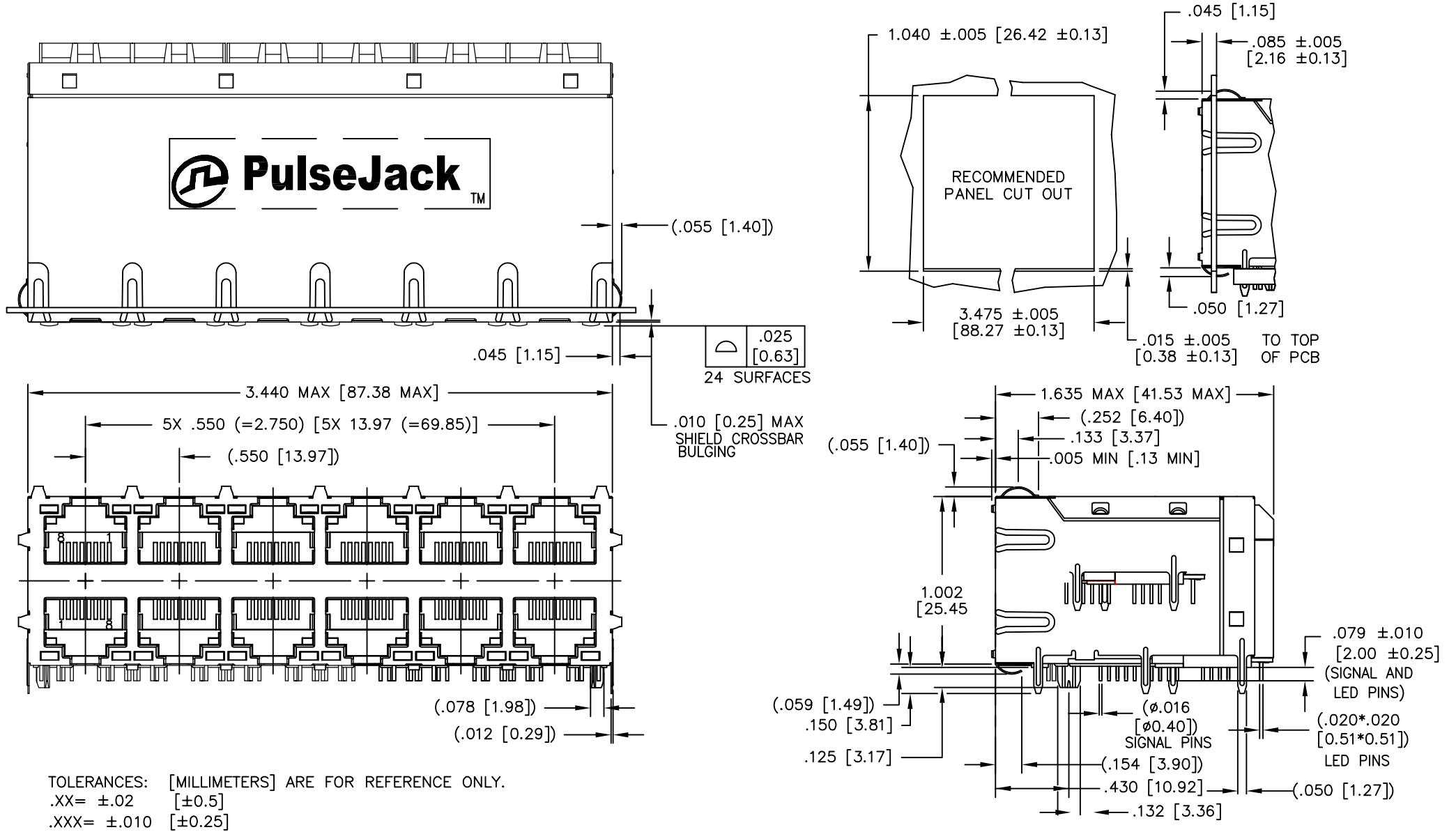

© Copyright, 2017. Pulse Electronics Corp. All rights reserved. Pulse confidential & proprietary. (04/24/17)

PRODUCT DESCRIPTION	TLA DRAWING	PS DRAWING	SHEET	PART NO.	DATASHEET REV.
CONN,RJ45,2X6,1GPP,1:1,TY	JOB-3563NL-10	PS-2417.611-A	3 OF 4	JOB-3563NL	J

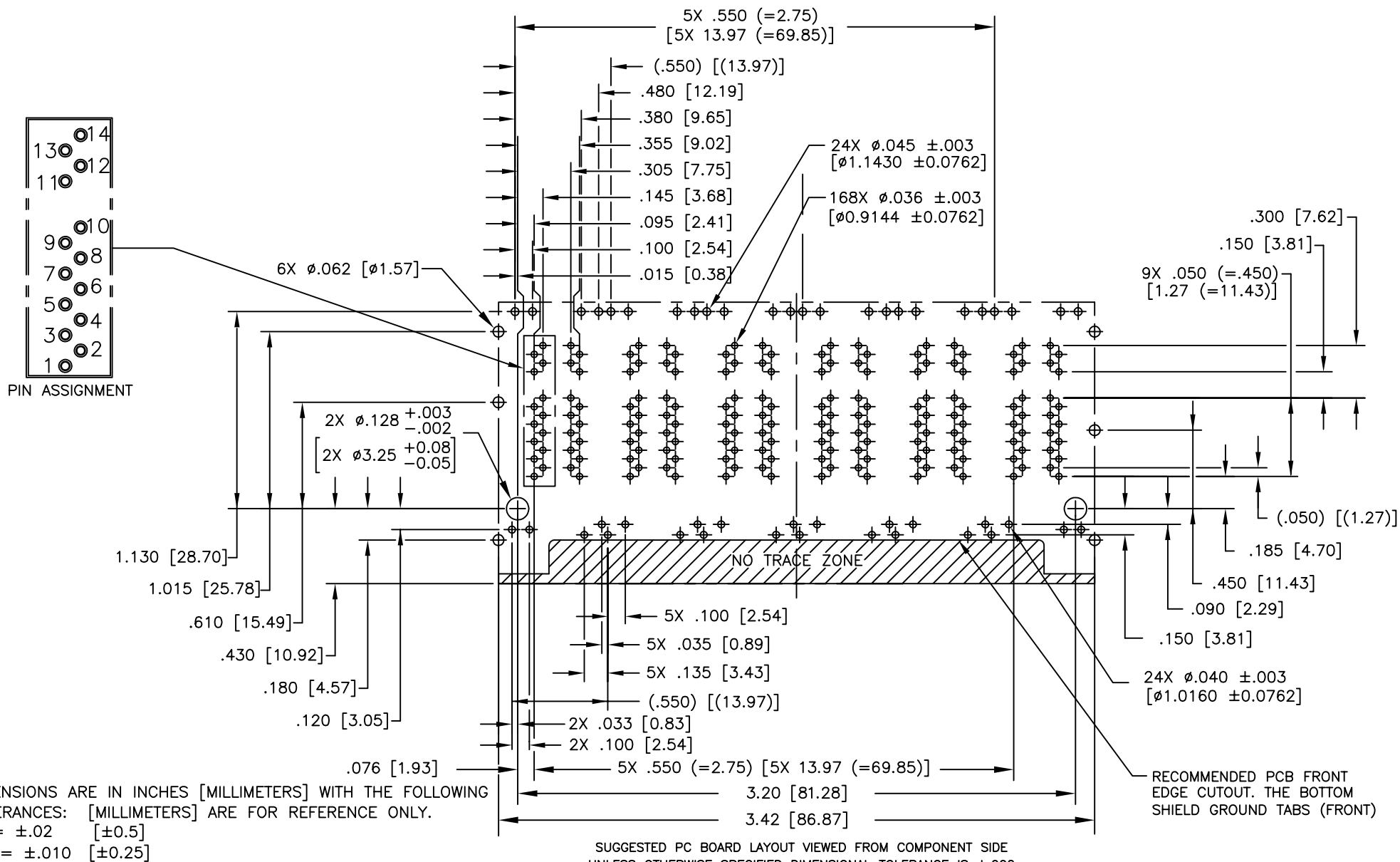

© Copyright, 2017. Pulse Electronics Corp. All rights reserved. Pulse confidential & proprietary. (04/24/17)

PRODUCT DESCRIPTION	TLA DRAWING	PS DRAWING	SHEET	PART NO.	DATASHEET REV.
CONN,RJ45,2X6,1GPP,1:1,1Y	JOB-3563NL-10	PS-2417.611-A	4 OF 4	JOB-3563NL	J

单击下面可查看定价，库存，交付和生命周期等信息

[>>Pulse\(普思\)](#)