

# DATA SHEET

WIRELESS COMPONENTS

Ceramic Chip Antenna

ANT1204LL20R0433A

433MHZ

1204 Series



FEATURES

- Compact size
- Omni-directional Radiation
- Tape & reel automatic mounting
- Reflow process compatible
- RoHS compliant

APPLICATIONS

- Smart meter
- Industrial remote control
- ISM band equipment

ORDERING INFORMATION

All part numbers are identified by the series, packing type, material, size, antenna type, working frequency and packing quantity.

**PART NUMBER**

**ANT 1204 L L20 R 0433A**  
 (1) (2) (3) (4) (5) (6)

---

**(1) PRODUCT**

ANT = Antenna

---

**(2) SIZE**

1204=12× 4 mm

---

**(3) ANTENNA TYPE**

L, F, A=Chip antenna

---

**(4) SERIAL NO.**

L20

---

**(5) PACKING STYLE**

R = Tape and Reel

---

**(6) WORKING FREQUENCY**

0433=433 MHz

---

**PHYCOMP CTC**

CAN4311759200431K

---

**I2NC**

431175920043

---

**SPECIFICATION**

Table 1

DESCRIPTION	VALUE
Centre Frequency	433 MHz
Bandwidth	28M Hz (Typ.)
Return Loss	6.5 dB min
Polarization	Linear
Azimuth Beamwidth	Omni-directional
Peak Gain	0.83 dBi (Typ.)
Impedance	50 Ω
Operating Temperature	- 40~105 °C
Maximum Power	1 W
Termination	Ni / Sn (Environmentally-Friendly Leadless)
Resistance to Soldering Heats	260°C , 10sec.

**NOTE**

I. The specification is defined on Yageo evaluation board

**DIMENSIONS**

Table 2 Machinical Dimension

	DIMENSION
L (mm)	12.00 ±0.50
W (mm)	4.00 ±0.50
T (mm)	1.50 ±0.30
A (mm)	0.85 ±0.35

**OUTLINES**

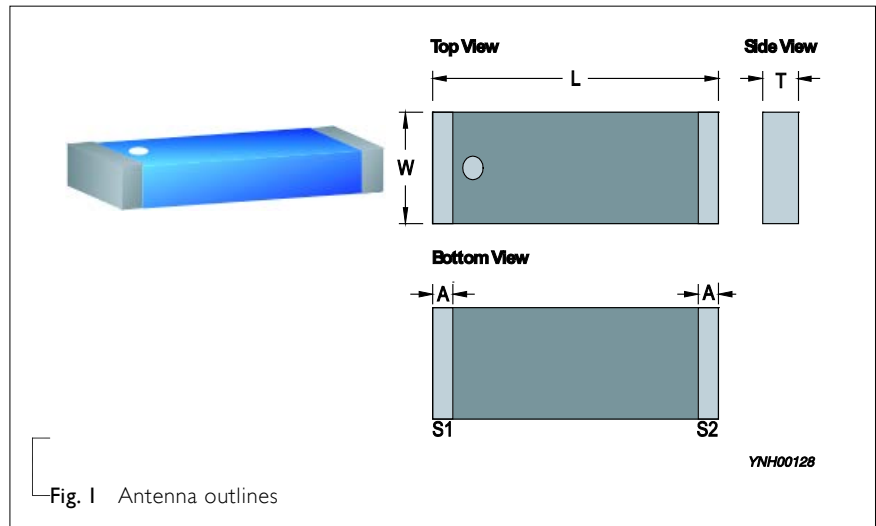
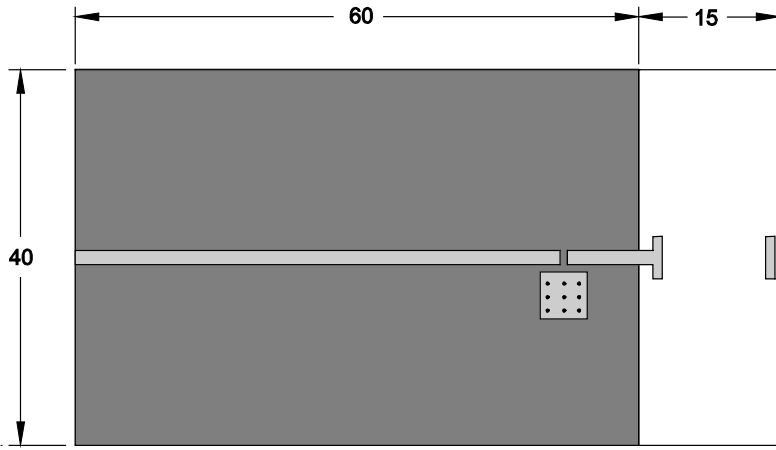

Fig. 1 Antenna outlines

Table 3 Termination configuration

TERMINAL NAME	FUNCTION
S1	Feeding Point
S2	Soldering Point

REFERENCE DESIGN OF EVALUATION BOARD



Unit : mm

Fig. 2 Outlook and dimension of evaluation board

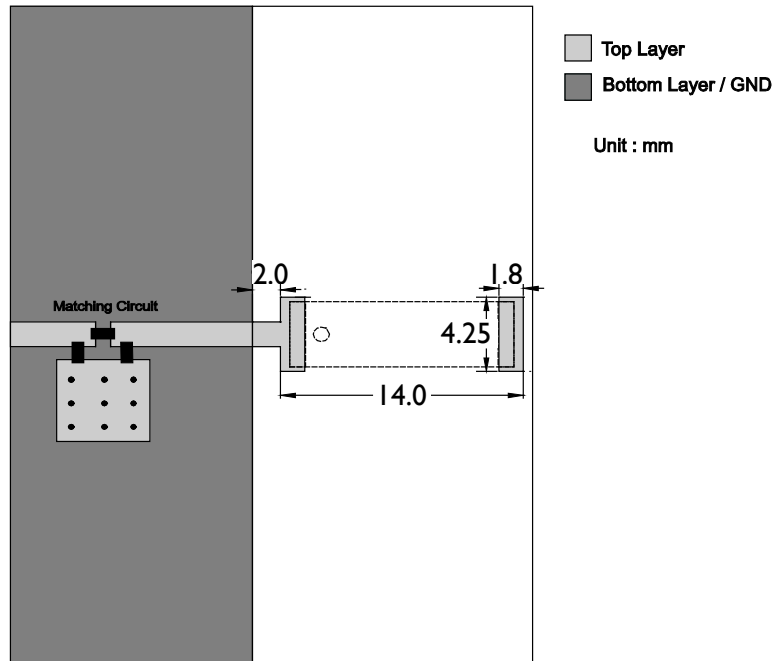

Unit : mm

YNH00129

Fig. 3 Details of soldering Pad

**ELECTRICAL PERFORMANCES**

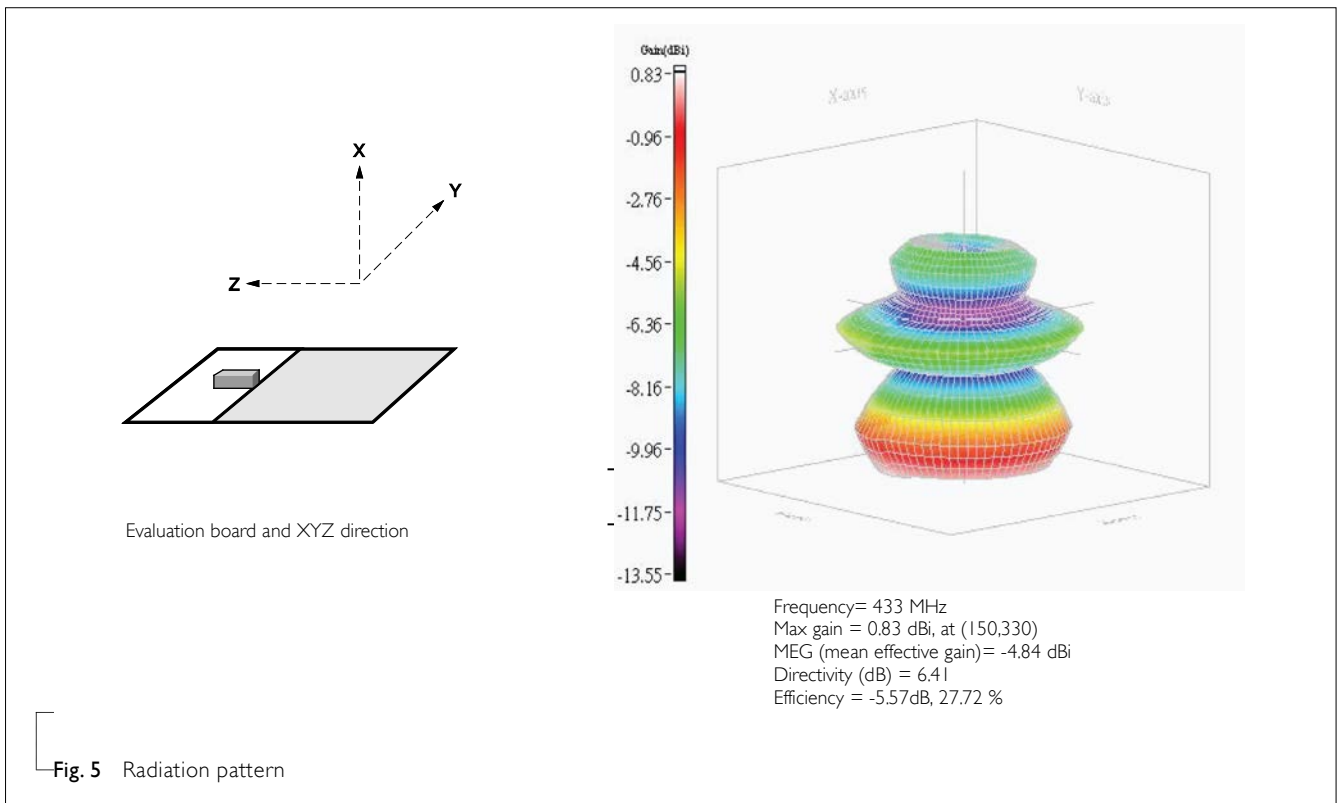
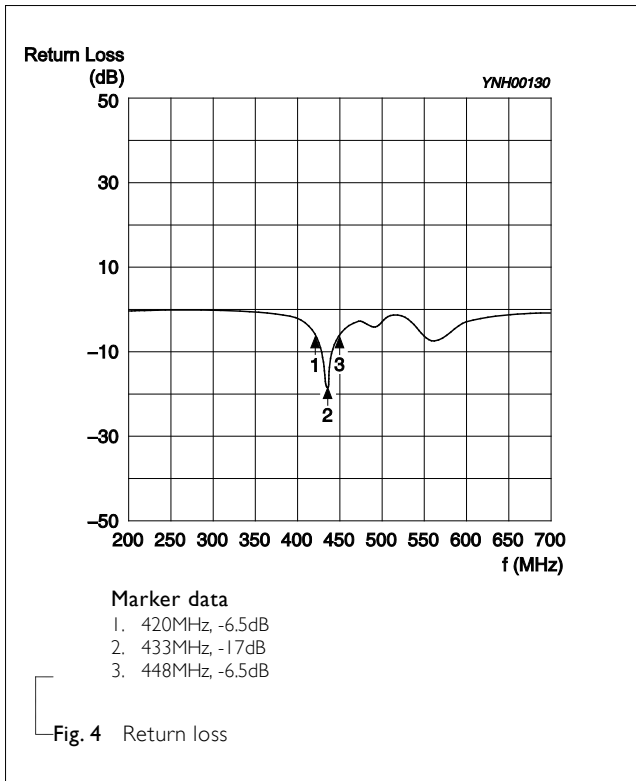

REVISION HISTORY

REVISION	DATE	CHANGE NOTIFICATION	DESCRIPTION
Version 0	Nov. 05, 2013	-	- New data sheet for Ceramic Chip Antenna, 433MHz application, 1204 series

单击下面可查看定价，库存，交付和生命周期等信息

[>>Pulse\(普思\)](#)