

REVISION RECORD		
REV	DESCRIPTION	DRFT
11	OLD DRAWING CHECK IN	APPFU 10/12/07
12	MODIFY DRAWING	Tuki 9/19/08 Victor
13	REASSIGN PIN NUMBER	27/03/12

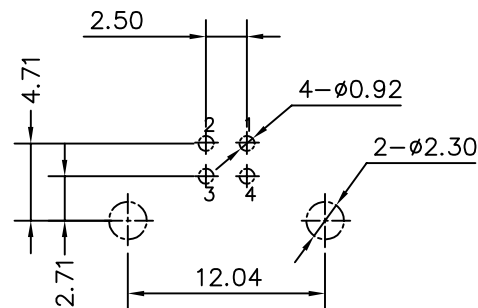
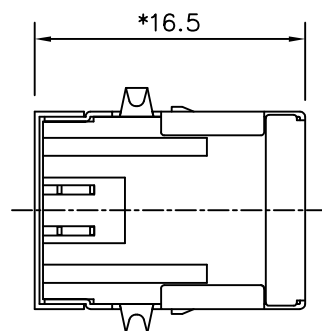
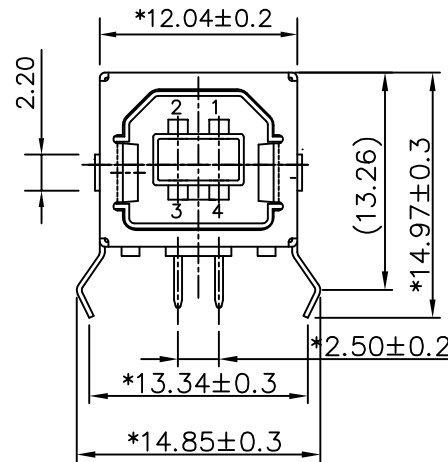
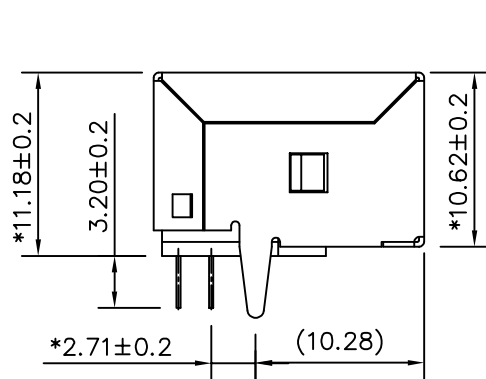

USB-PCB LAYOUT

NOTES:

- MATERIAL:  
 TERMINAL-C5191 PHOSPHOR BRONZE HARD.  
 SHIELD-COPPER ALLOY  
 HOUSING-PBT+30% G.F. UL94V-0
- PLATING: CONTACT-GOLD PLATING OVER NICKEL  
 TERMINAL-75u" Tin MIN OVER 50u"-100u" NICKEL  $\Delta$ 2  
 SHIELD-120u" TIN MIN OVER 50u" NICKEL.  
 OR 100u"~120u" NICKEL OVER 40u" Cu.
- GAP: 0.25mm (Max.)
- ELECTRICAL:  
 VOLTAGE RATING : 30 VAC RMS.  
 CURRENT RATING : 1.0 AMP  
 CONTACT RESISTANCE : 30 MILLIOHMS MAX  
 INSULATION RESISTANCE : 1000 MEGOHMS MIN @500 VDC  
 DIELECTRIC STRENGTH : 750 VAC RMS 60 HZ, 1 MIN  
 OPERATING LIFE : 1500 CYCLES MIN  
 MATING FORCE : 3.5 KGS MAX  
 UNMATING FORE : 1 KGS MIN
- ENVIRONMENTAL:  
 STORAGE : -40°C TO +85°C  
 OPERATION : -40°C TO +85°C  
 CAPACITANCE : 2 PF MAX 1KHZ  
 WAVE SOLDER TEMPERATURE: 230-250°C.(3-5 SECONDS)  
 ROHS COMPLIANT  
 6.UL & CUL FILE NO. E163191  
 OLD DRAWING NUMBER:GE813A02-LC

ROHS P/N	REV	MATERIAL	SHIELD PLATING	PLATING
E8144-B02022-L	A	PBT BLACK	PLATING TIN	Au6u"

MM (INCH)		DFTO SAMMY	DATE 03/14/05	Pulse Electronics		RoHS Compliant	
TOLERANCES EXCEPT AS NOTED		CHKD ALICE	DATE 3/29/2012	TITLE USB Series B			
MM		APPVLTIM	DATE 3/29/2012	4-Position Dip Type			
.0 ± 0.20	±	MATERIAL :		DRAWING NO. E8144-BOX2X-L2		SIZE	REV
.00 ± 0.15	±	ANGLES ± 0.5°		/PART NO. E8144-BOX2X-L2		A3	13
.000 ± 0.075	±	THIRD ANGLE PROJECTION		SCALE : 3:1		DO NOT SCALE DRAWING	
		QTY :		SHEET 1		OF 1	

单击下面可查看定价，库存，交付和生命周期等信息

[>>Pulse\(普思\)](#)