











Outdoor 5G/4G Radome Omni Dipole Antenna

RO600/71NFKIT – 617 to 7125 MHz



Features & Applications:

-  617-960/1450-7125MHz
-  WiFi 6E, 4G/5G FR1
-  Includes Band 71 (617-698MHz) and CBRS Bands 42 and 48 (3400-3700MHz)
-  Dual Band WiFi Support
-  Omni Directional radiation pattern
-  Average peak gain: 617-960 MHz 2.5dBi, 1450-4200 MHz 4.0dBi, 4400-7125 MHz 4.3dBi
-  Size: Dia. 2.45" (62.2mm) Height 8.64" (219.4mm)
-  N-Female Connector (720-hour salt spray rating)
-  DC Grounded
-  Bracket, mounts to Ø1"-2.12" (25.4-54mm) pole (720-hour salt spray rating)
-  Utility boxes, Smart metering, IoT Devices

Electrical specifications @ 25° C

Frequency Bands – 617-960/1450-2700/3300-4200/4400-5000/5150-5925/6000-7125 MHz

Antenna type ¹	Nominal Impedance	Polarization	Radiation pattern	Power withstanding	DC Ground
Dipole	50Ω	Vertical	Omni	10W	Yes

Frequency (MHz)	617-960	1450-2700	3300-4200	4400-5000	5150-5925	6000-7125
VSWR	2:1	2:1	2:1	2:1	2:1	2:1
Average Peak Gain (dBi)	2.2	3.0	5.0	4.1	3.3	4.3
Average Efficiency (%)	76	77	76	65	60	59
HPBW Vertical Plane (°)	62	37	30	25	50	35

Mechanical / Environmental Specifications

RO600/71NFKIT

Size (Diameter x Height)	Color ²	Weight	Connector Type	Fixing System ³
62.2 (2.45") x 219.4 (8.64") mm	White	620grms (1.37lbs)	N-Female	ROBKTSS

Housing Material	Ingress Protection	RoHS-6 Compliant	Operating Temperature	Storage Temperature
PET+PC, UV rated	IP67	Yes	-40°C to 80°C	-40°C to 80°C

Notes:

1. Measured with bracket.
2. Custom colors available upon request.
3. Stainless steel mounting bracket (with hardware) included.
Ø0.625" (15.9mm) hole required if not used with ROBKTSS mounting bracket.

Outdoor 5G/4G Radome Omni Dipole Antenna

RO600/71NFKIT – 617 to 7125 MHz

Mechanical Drawing

RO600/71NFKIT

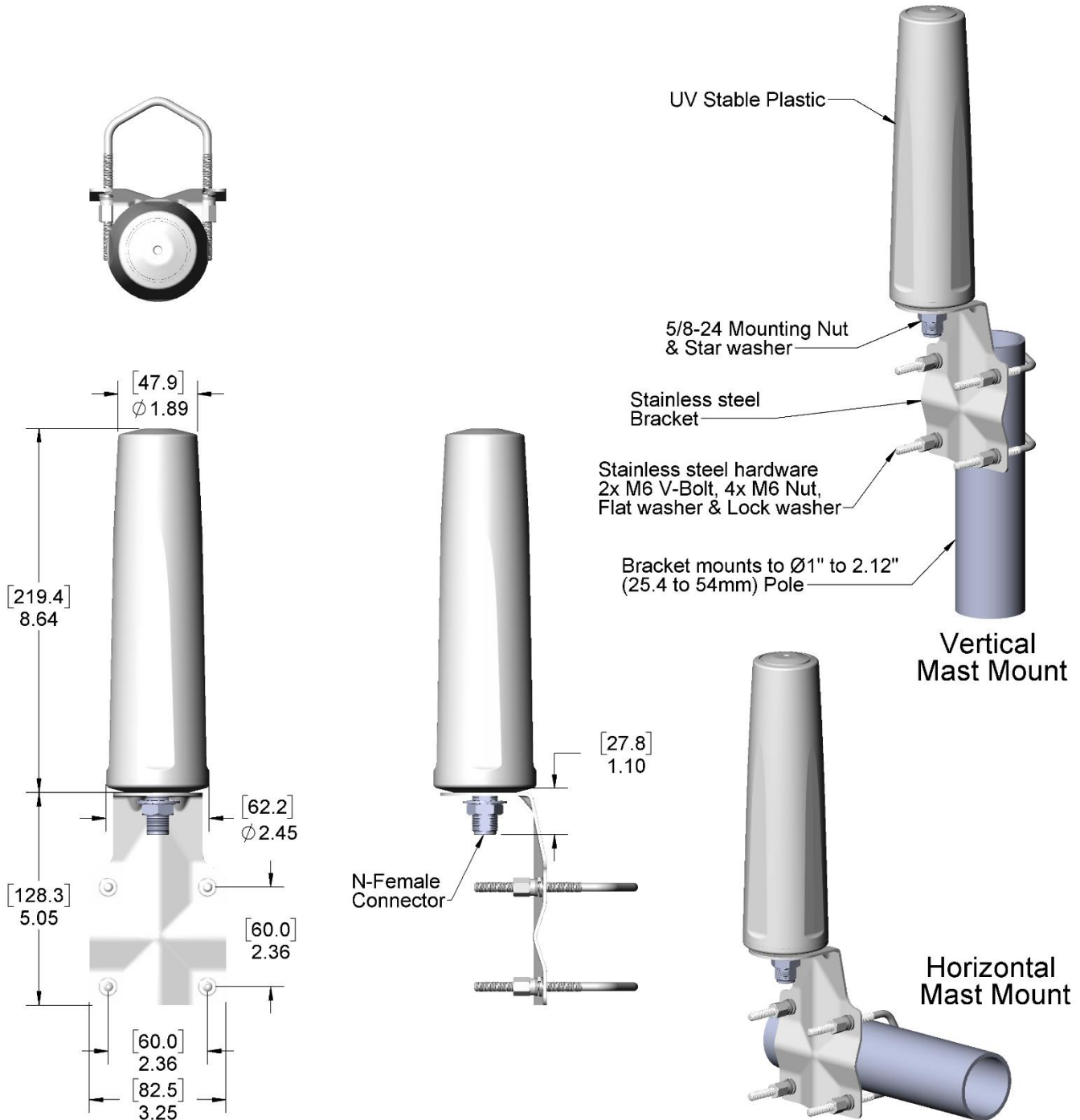

Dimensions: Inches (mm)

Unless otherwise specified, all tolerances are ±.010 (0.25mm)

Test Setup

RO600/71NFKIT

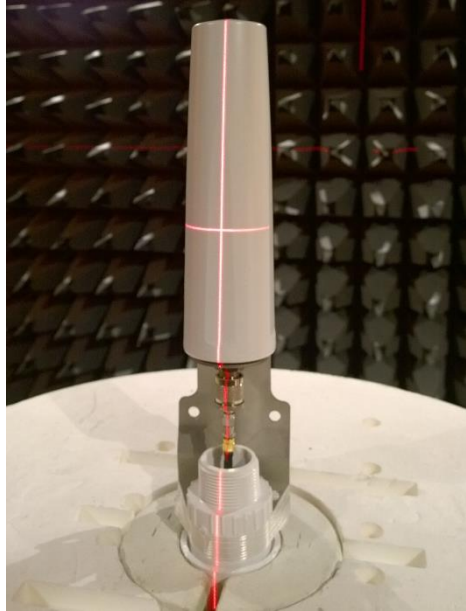

RO600/71NFKIT antenna sample measured on bracket.

Charts- VSWR

RO600/71NFKIT

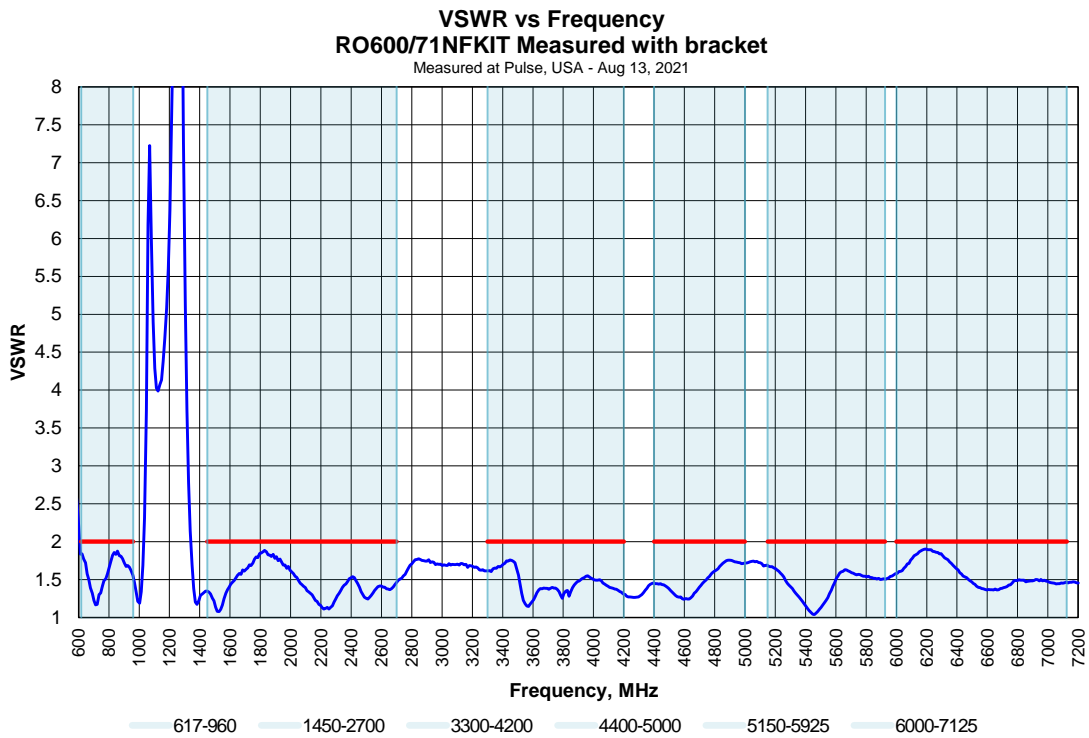

Charts- Peak Gain and Efficiency

RO600/71NFKIT

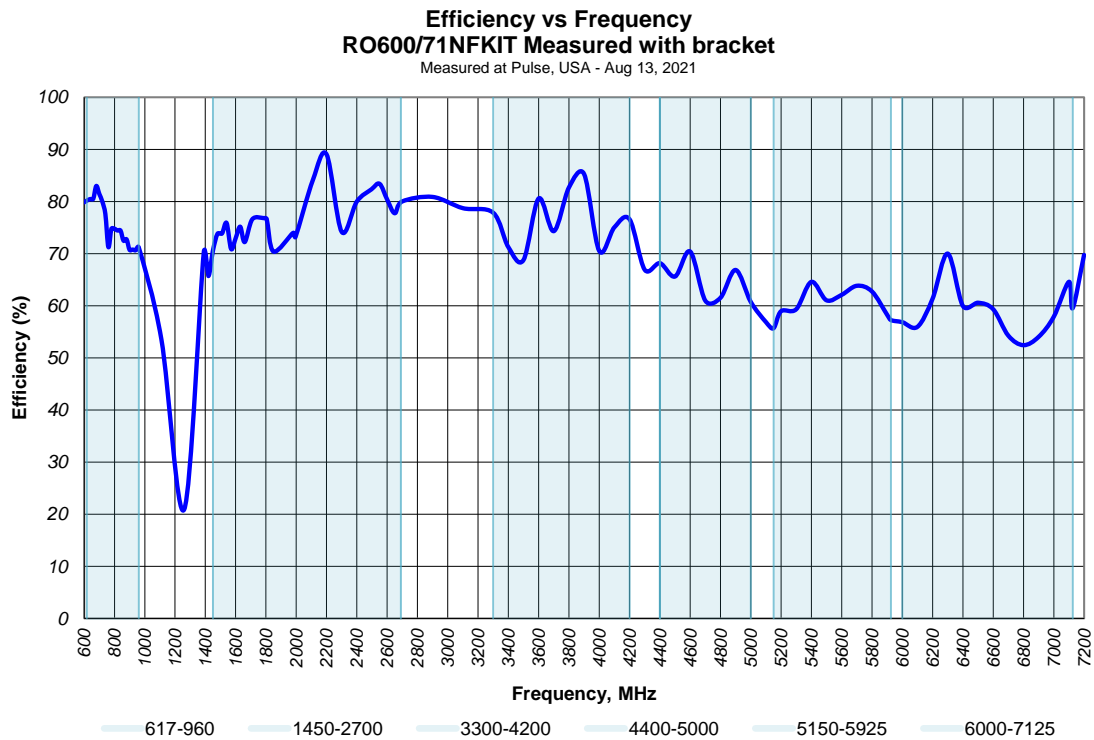
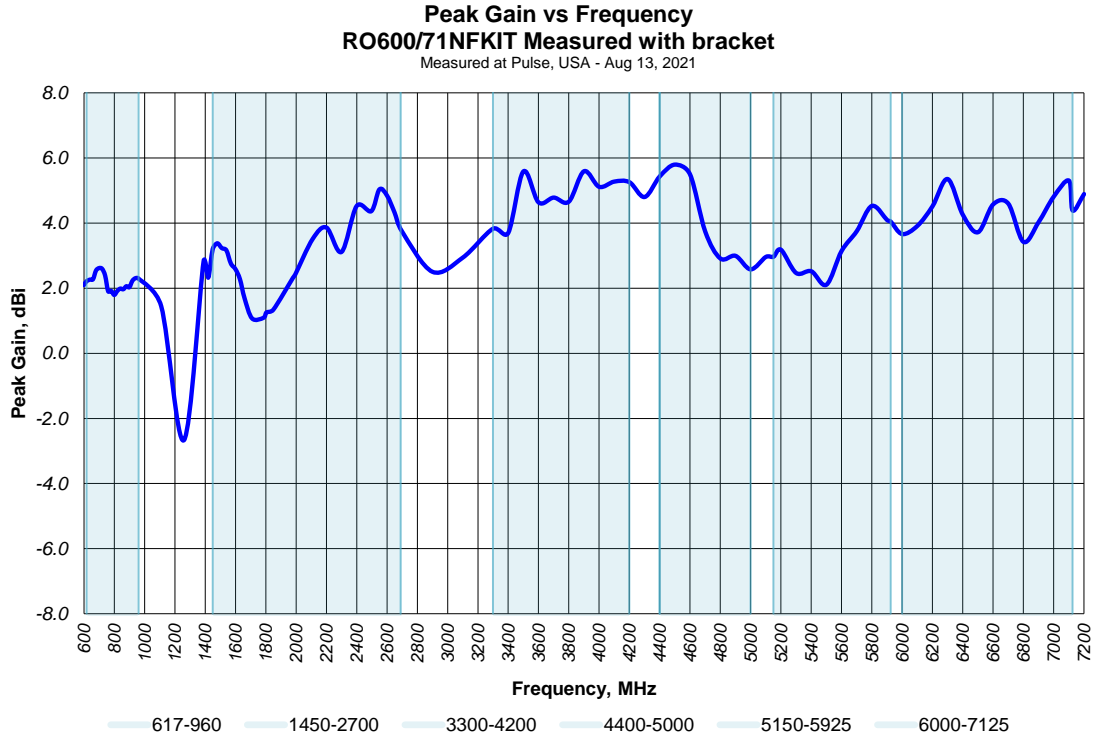

Charts- XY Gain Plots

RO600/71NFKIT

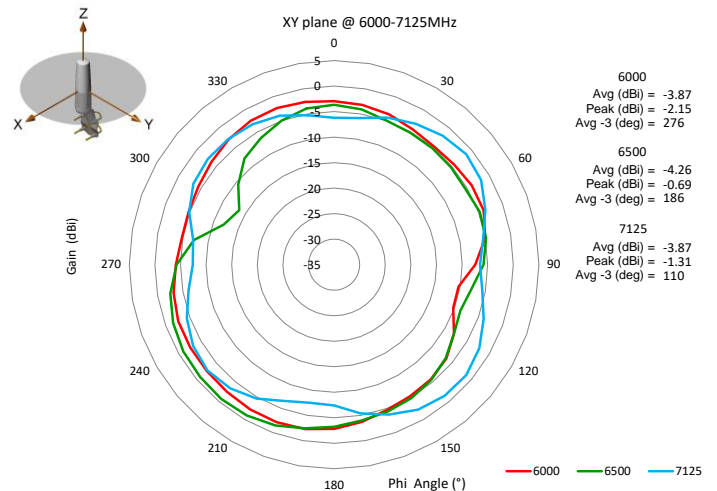
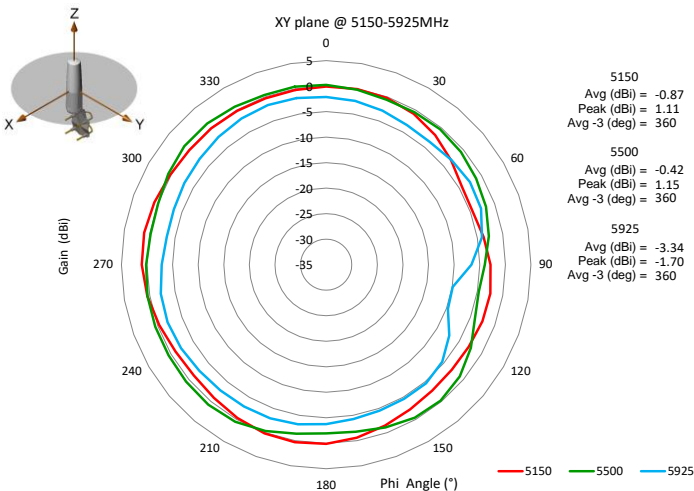
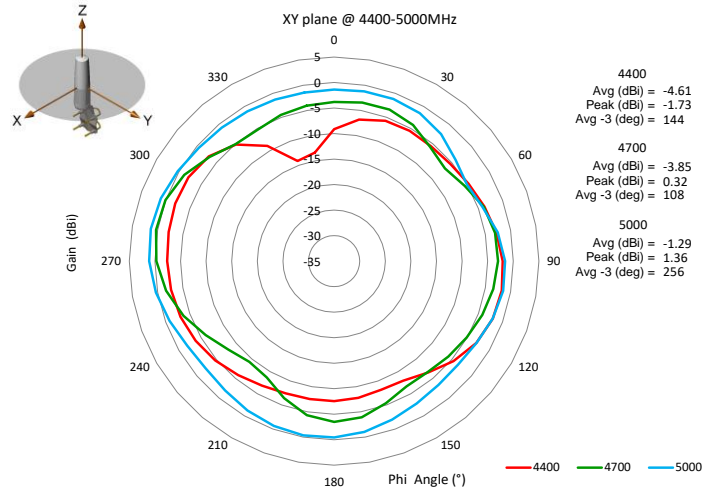
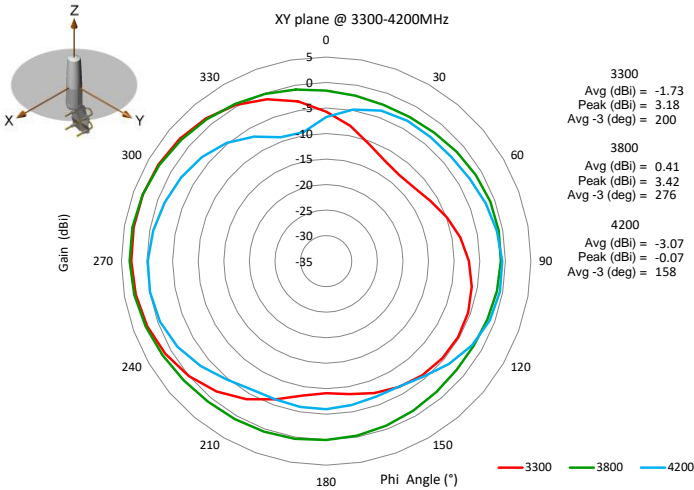
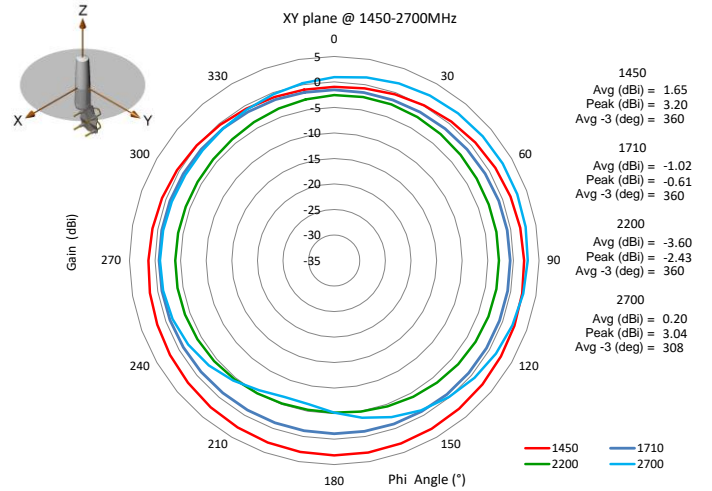
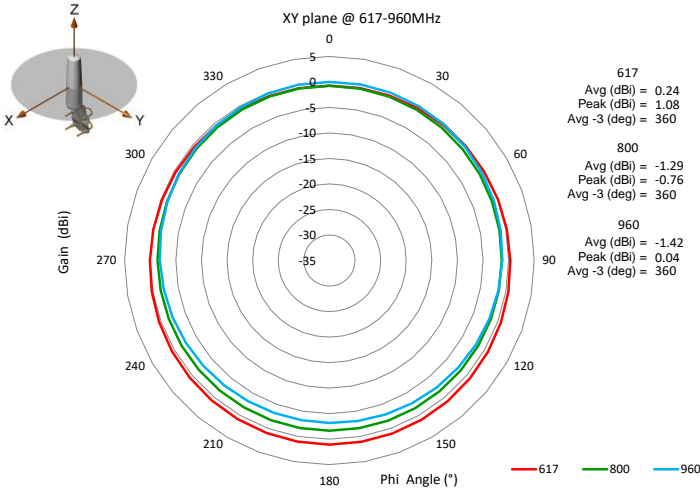

Charts – XZ Gain Plots

RO600/71NFKIT

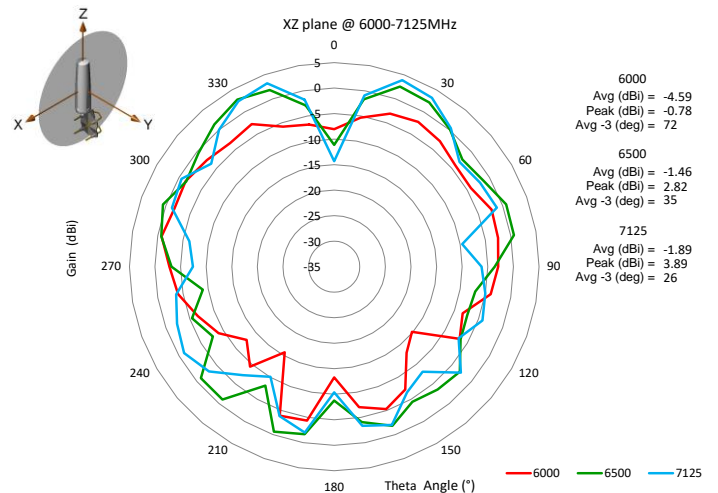
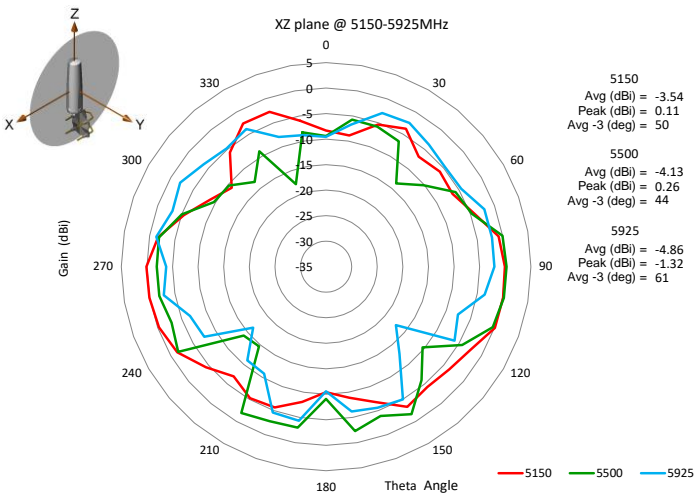
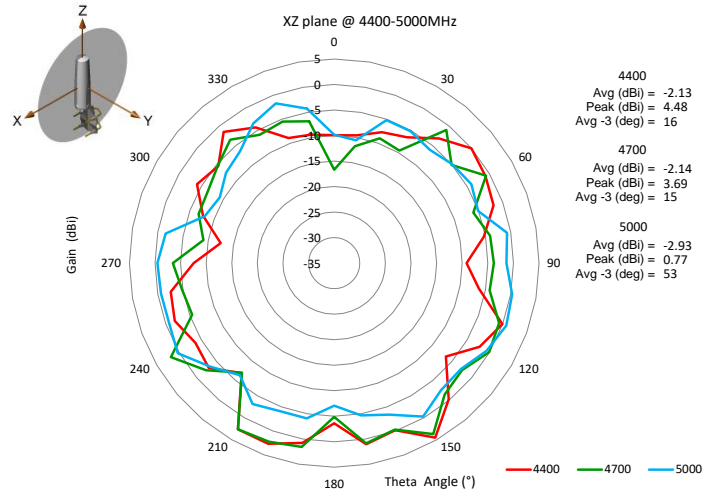
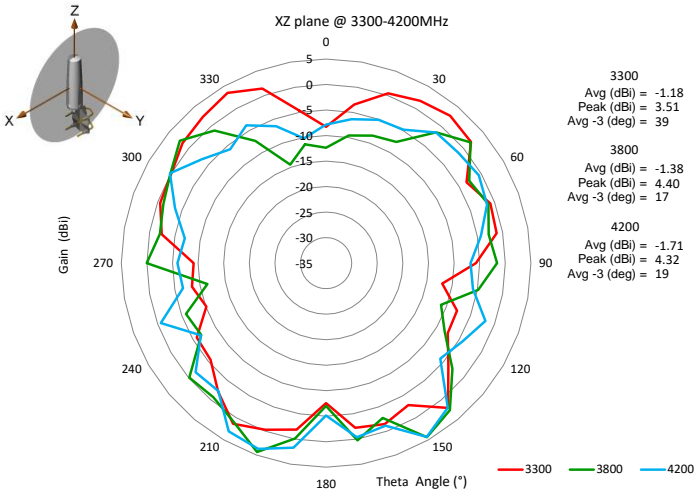
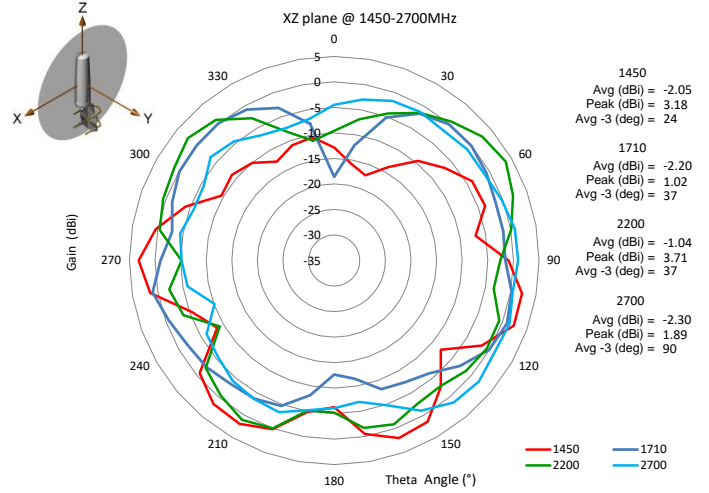
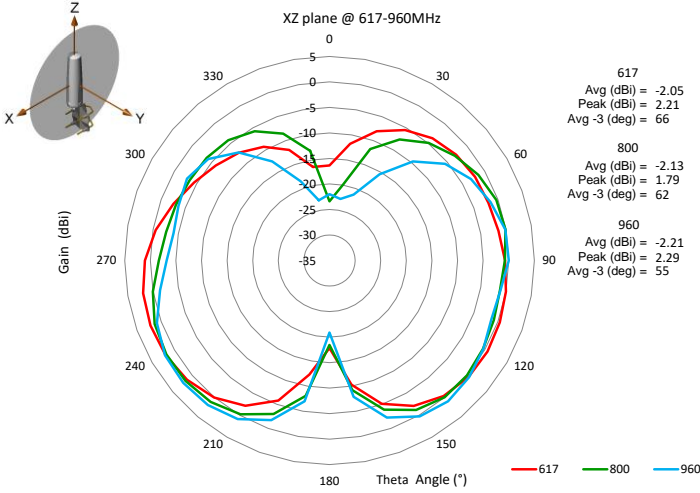

Outdoor 5G/4G Radome Omni Dipole Antenna

RO600/71NFKIT – 617 to 7125 MHz

Packaging

RO600/71NFKIT

Packaging info:

- 1 antenna packed in single box (285x155x90mm)
- 9 single boxes packed in out carton box (570x375x200mm)
- 1 label on each box with part number, description, date code.

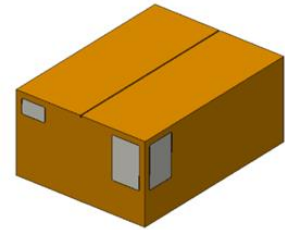
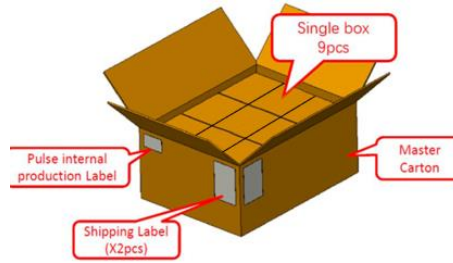

Master carton size
570x375x200mm

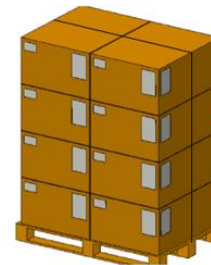

1 Pallet can load 24 master carton
Total = 24x9 = 216pcs

P.S.:
(1) Pallet size: 1.2m X 0.8m
(2) Stack up height = 1.5m

Additional Product Info

RO600/71NFKIT

Family Products – RO (Radome Omni)

5G / 4G RO Products

Orderable PN	Connector Type	DC Ground	Color
RO600/71NFKIT	N-Female	Yes	White
RONG600/71NFKIT ¹	N-Female	No	White
RO600/71NF ²	N-Female	Yes	White
RONG600/71NF ^{1, 2}	N-Female	No	White
ROBKTSS (Mounting bracket with hardware)			

Notes:

- 'NG' stands for 'No DC Ground'. RONG600/71NF (KIT) No DC ground version has higher power handling (60W).
- Antenna only (bracket not included).
- Please contact sales for availability, lead time, and/or any special requests. Samples available upon request.

For More Information:

Americas - antennas.us@pulseelectronics.com | Europe – antennas.eu@pulseelectronics.com | Asia – antennas.as@pulseelectronics.com | Questions? +1-800-ANTENNA
Performance warranty of products offered on this data sheet is limited to the parameters specified. Data is subject to change without notice. Other brand and product names mentioned herein may be trademarks or registered trademarks of their respective owners. © Copyright , 2020. Pulse Electronics, Inc. All rights reserved.

单击下面可查看定价，库存，交付和生命周期等信息

[>>Pulse\(普思\)](#)