

High Frequency Wire Wound Transformers

EP10+ Platforms - SMT - PA5130.XXXNL AND PA5131.XXXNL



- Ⓢ Industry standard footprint, 2X more power handling
- Ⓢ **Power Range:** PA5130.XXXNL up to 25W;
PA5131.XXXNL up to 35W
- Ⓢ **Height:** 15.5mm Max
- Ⓢ **Footprint:** 15.5mm x 13.0mm Max
- Ⓢ **Topology:** Forward and Flyback

Pulse PN	Electrical Specifications @25°C – Operating Temperature -40°C to 125°C ¹				Schematic
PA5130.001NL	Pri. Inductance	(1-2)	80	uH ± 10%	<p>Flyback Transformer</p>
	Lk. Inductance	(1-2) w/ (5,6,7,8) shorted	1.5	uH Max	
	DCR	(1-2)	130	mΩ Max	
		(3-4)	90		
		(8-5)	9		
		(7-6)	9		
	Hi-Pot	Pri-Sec	2250	Vdc	
K1 Factor	1250				
PA5130.002NL	Pri. Inductance	(1-2)	80	uH ± 10%	<p>Flyback Transformer</p>
	Lk. Inductance	(1-2) w/ (5,6,7,8) shorted	1.5	uH Max	
	DCR	(1-2)	130	mΩ Max	
		(3-4)	90		
		(8-5)	19		
		(7-6)	19		
	Hi-Pot	Pri-Sec	2250	Vdc	
K1 Factor	1250				
PA5130.003NL	Pri. Inductance	(1-2)	80	uH ± 10%	<p>Flyback Transformer</p>
	Lk. Inductance	(1-2) w/ (5,6,7,8) shorted	1.5	uH Max	
	DCR	(1-2)	130	mΩ Max	
		(3-4)	90		
		(8-5)	75		
		(7-6)	75		
	Hi-Pot	Pri-Sec	2250	Vdc	
K1 Factor	1250				
PA5130.004NL	Pri. Inductance	(1-2)	15	uH ± 10%	<p>Flyback Transformer</p>
	Lk. Inductance	(1-2) w/ (5,6,7,8) shorted	0.7	uH Max	
	DCR	(1-2)	32	mΩ Max	
		(3-4)	90		
		(8-5)	9		
		(7-6)	9		
	Hi-Pot	Pri-Sec	2250	Vdc	
K1 Factor	469				

High Frequency Wire Wound Transformers

EP10+ Platforms - SMT - PA5130.XXXNL AND PA5131.XXXNL



Pulse PN	Electrical Specifications @25°C – Operating Temperature -40°C to 130°C ¹				Schematic
PA5130.005NL	Pri. Inductance	(1-2)	15	uH ± 10%	<p>Flyback Transformer</p>
	Lk. Inductance	(1-2) w/ (5,6,7,8) shorted	0.7	uH Max	
	DCR	(1-2)	32	mΩ Max	
		(3-4)	90		
		(8-5)	19		
		(7-6)	19		
	Hi-Pot	Pri-Sec	2250	Vdc	
K1 Factor	469				
PA5130.006NL	Pri. Inductance	(1-2)	15	uH ± 10%	<p>Flyback Transformer</p>
	Lk. Inductance	(1-2) w/ (5,6,7,8) shorted	0.7	uH Max	
	DCR	(1-2)	32	mΩ Max	
		(3-4)	90		
		(8-5)	75		
		(7-6)	75		
	Hi-Pot	Pri-Sec	2250	Vdc	
K1 Factor	469				
PA5131.001NL	Pri. Inductance	(1-2)	210	uH Min	<p>Forward Transformer</p>
	Lk. Inductance	(1-2) w/ (5,6,7,8) shorted	0.7	uH Max	
	DCR	(1-2)	45	mΩ Max	
		(3-4)	90		
		(8-5)	9		
		(7-6)	9		
	Hi-Pot	Pri-Sec	2250	Vdc	
K1 Factor	26				
PA5131.002NL	Pri. Inductance	(1-2)	210	uH Min	<p>Forward Transformer</p>
	Lk. Inductance	(1-2) w/ (5,6,7,8) shorted	0.7	uH Max	
	DCR	(1-2)	45	mΩ Max	
		(3-4)	90		
		(8-5)	19		
		(7-6)	19		
	Hi-Pot	Pri-Sec	2250	Vdc	
K1 Factor	26				
PA5131.003NL	Pri. Inductance	(1-2)	210	uH Min	<p>Forward Transformer</p>
	Lk. Inductance	(1-2) w/ (5,6,7,8) shorted	0.7	uH Max	
	DCR	(1-2)	45	mΩ Max	
		(3-4)	90		
		(8-5)	75		
		(7-6)	75		
	Hi-Pot	Pri-Sec	2250	Vdc	
K1 Factor	26				

High Frequency Wire Wound Transformers

EP10+ Platforms - SMT - PA5130.XXXNL AND PA5131.XXXNL



Pulse PN	Electrical Specifications @25°C – Operating Temperature -40°C to 130°C ¹				Schematic
PA5131.004NL	Pri. Inductance	(1-2)	13	uH Min	<p>Forward Transformer</p>
	Lk. Inductance	(1-2) w/ (5,6,7,8) shorted	0.15	uH Max	
	DCR	(1-2)	45	mΩ Max	
		(3-4)	90		
		(8-5)	9		
		(7-6)	9		
	Hi-Pot	Pri-Sec	2250	Vdc	
K1 Factor	104				
PA5131.005NL	Pri. Inductance	(1-2)	13	uH Min	<p>Forward Transformer</p>
	Lk. Inductance	(1-2) w/ (5,6,7,8) shorted	0.15	uH Max	
	DCR	(1-2)	45	mΩ Max	
		(3-4)	90		
		(8-5)	19		
		(7-6)	19		
	Hi-Pot	Pri-Sec	2250	Vdc	
K1 Factor	104				
PA5131.006NL	Pri. Inductance	(1-2)	13	uH Min	<p>Forward Transformer</p>
	Lk. Inductance	(1-2) w/ (5,6,7,8) shorted	0.15	uH Max	
	DCR	(1-2)	45	mΩ Max	
		(3-4)	90		
		(8-5)	75		
		(7-6)	75		
	Hi-Pot	Pri-Sec	2250	Vdc	
K1 Factor	104				

Notes:

- The temperature of the component (ambient plus temperature rise) must be within the stated operating temperature range.
- For flyback topology applications, it is necessary to ensure that the transformer will not saturate in the application. The peak flux density (Bpk) should remain below 2700Gauss. To calculate the peak flux density use the following formula:
 $B_{pk} \text{ (Gauss)} = K1_Factor * I_{pk} \text{ (A)}$
- In high volt-μsec applications, it is important to calculate the core loss of the transformer. Approximate transformer core loss can be calculated as:

$$\text{CoreLoss (W)} = 8.38E-14 * (\text{Freq_kHz})^{1.63} * (\Delta B_Gauss)^{2.63}$$

where ΔB can be calculated as:

For Flyback Topology: $\Delta B = K1_Factor * \Delta I \text{ (A)}$

For Forward Topology: $\Delta B = K1_Factor * \text{Volt-}\mu\text{sec}$

- Optional Tape & Reel packaging can be ordered by adding a "T" suffix to the part number (i.e. PA5130.001NL becomes PA5130.001NLT). Pulse complies with industry standard tape and reel specification EIA481. The tape and reel for this product has a width (W=32mm), pitch (Po=24mm) and depth (Ko=15.7mm).

Mechanical

PA5130.XXXNL/ PA5131.XXXNL

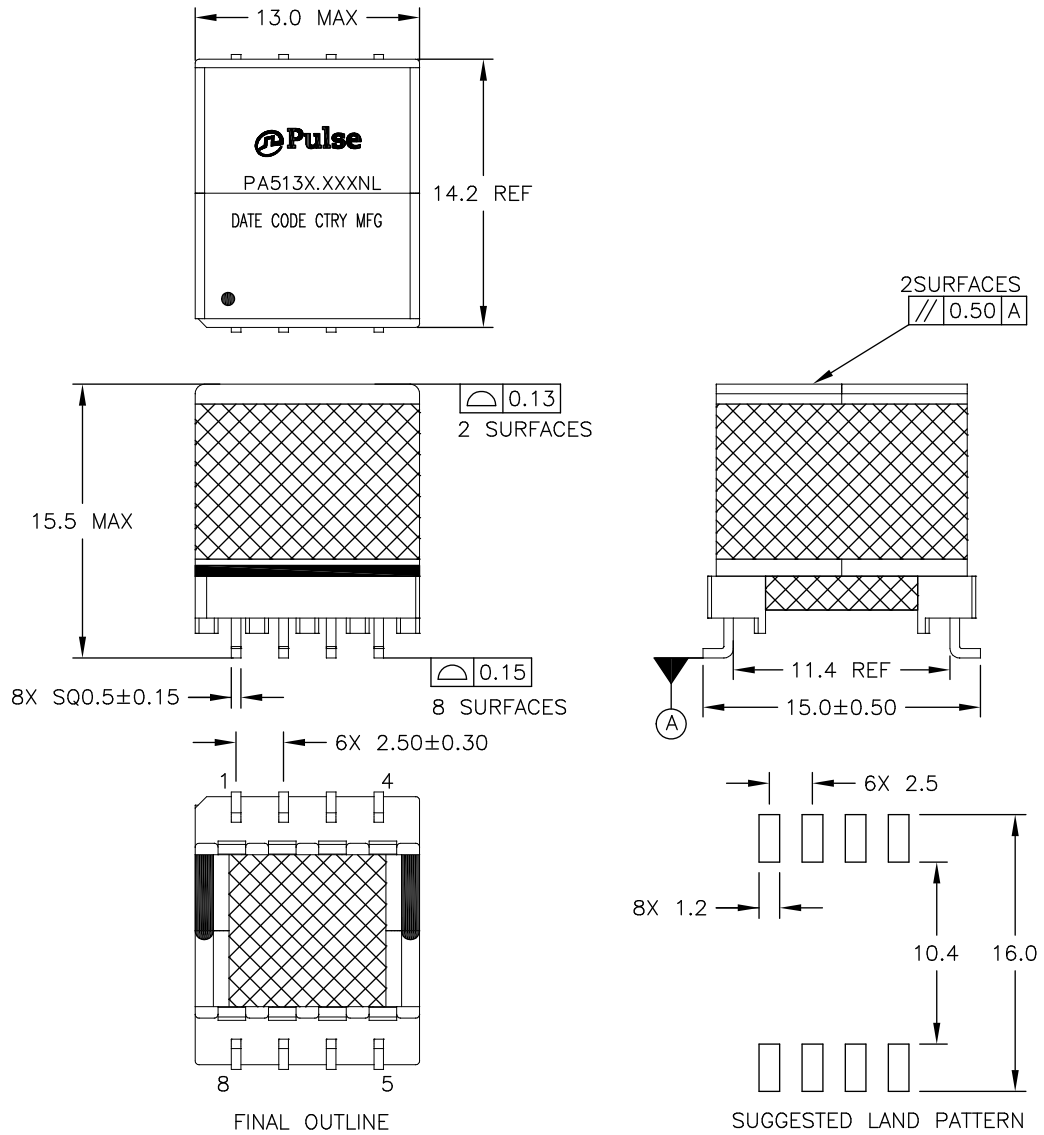

High Frequency Wire Wound Transformers

EP10+ Platforms - SMT - PA5130.XXXNL AND PA5131.XXXNL

TAPE & REEL INFO

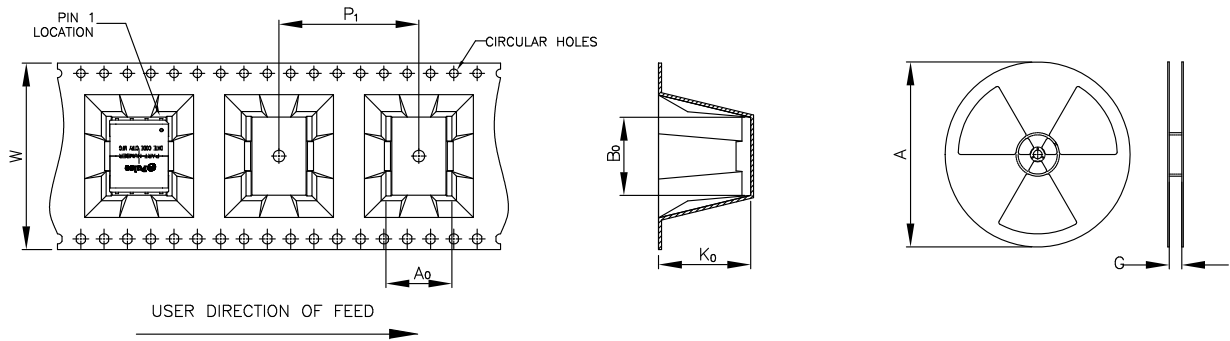

SURFACE MOUNTING TYPE, REEL/TAPE LIST

PART NUMBER	REEL SIZE (mm)		TAPE SIZE (mm)					QTY
	A	G	W	P ₁	A ₀	B ₀	K ₀	PCS/REEL
PA5130.XXXNL/ PA5131.XXXNL	Ø330	24.4	32	24	12.4	14.6	15.7	125

For More Information:

Americas - prodinfo_power@pulseelectronics.com | Europe - power-apps-europe@pulseelectronics.com | Asia - power-apps-asia@pulseelectronics.com

Performance warranty of products offered on this data sheet is limited to the parameters specified. Data is subject to change without notice. Other brand and product names mentioned herein may be trademarks or registered trademarks of their respective owners. © Copyright, 2021. Pulse Electronics, Inc. All rights reserved.

单击下面可查看定价，库存，交付和生命周期等信息

[>>Pulse\(普思\)](#)