

# Isolation Power Transformers

Toroid Platform SMD PH9085.XXXNL and PM2180.XXXNL



- ④ Push Pull Converter Transformer
- ④ Functional insulation for isolated power supply driver
- ④ 2.5KVrms isolation (380Vrms continuous)

## Electrical Specifications @ 25°C - Operating Temperature -40°C to +125°C

Part Number		Inductance (1-3) ( $\mu\text{H} \pm 35\%$ )	Leakage Inductance (1-3) with (4-6) shorted ( $\mu\text{H} \text{ MAX}$ )	Capacitance (1, 2, 3) to (4, 5, 6) (pF MAX)	DCR (1-3) ( $\Omega \text{ MAX}$ )	DCR (4-6) ( $\Omega \text{ MAX}$ )	ET MAX (1-3) <sup>1</sup> (V- $\mu\text{sec} \text{ Max}$ )	Turns Ratio (1:3) (6:4)	Isolated Voltage <sup>2</sup> (Vrms)
Commerical	Automotive <sup>6</sup>								
PH9085.011NL	PM2180.011NL	1020	0.8	30	0.60	0.65	22	1CT : 1CT	2500
PH9085.012NL	PM2180.012NL	1020	0.6	40	0.85	1.60	22	1CT : 2CT	
PH9085.021NL	PM2180.021NL	1160	1.6	20	0.60	0.35	23.6	2CT : 1CT	
PH9085.034NL	PM2180.034NL	1020	0.6	40	0.60	0.75	22	3CT : 4CT	
PH9085.035NL	PM2180.035NL	1020	0.6	40	0.80	1.20	22	3CT : 5CT	
PH9085.038NL	PM2180.038NL	1020	0.7	40	0.85	2.00	22	3CT : 8CT	
PH9085.043NL	PM2180.043NL	1160	0.8	30	0.60	0.50	23.6	4CT : 3CT	
PH9085.083NL	PM2180.083NL	1160	2.0	15	0.60	0.30	23.6	8CT : 3CT	
PH9085.089NL	PM2180.089NL	1160	0.6	40	0.60	0.70	23.6	8CT : 9CT	

- Notes:**
- The ET Max is calculated to limit the core loss and temperature rise at 100KHz based on a bipolar flux swing of 210mT Peak.
  - For Push-Pull topology, where the voltage is applied across half the primary winding turns, the ET needs to be derated by 50% for the same flux swing.
  - The applied ET may need to be further derated for higher frequencies based on the temperature rise which results from the core and copper losses
    - To calculate total copper loss (W), use the following formula:  

$$\text{Copper Loss (W)} = \text{I}_{\text{rms\_Primary}}^2 * \text{DCR\_Primary} + \text{I}_{\text{rms\_Secondary}}^2 * \text{DCR\_Secondary}$$
    - To calculate total core loss (W), use the following formula:  

$$\text{Core Loss (W)} = 7.70\text{E-13} * (\text{Frequency in kHz})^{2.43} * (210 * [\text{ET}/\text{ET Max}])^{2.5}$$
 Where ET is the applied Volt Second, ET Max is the rated Volt Second for 210mT flux swing
  - To calculate temperature rise, use the following formula: Temperature Rise ( $^{\circ}\text{C}$ )  

$$= 340 * (\text{Core Loss (W)} + \text{Copper Loss (W)})$$
  - The AEC-Q200 temperature and humidity operational life testing was completed using a dielectric strength test of 2750Vdc.
  - Continuous isolation voltage confirmed by 125 $^{\circ}\text{C}$ /1000hrs accelerated aging with the bias voltage applied between primary and secondary windings.
  - The PM2180.XXXNL part numbers are AEC-Q200 and IATF16949 certified. The mechanical dimensions are 100% tested in production but do not necessarily meet a product capability index (Cpk) >1.33 and therefore may not strictly conform to PPAP.

## Mechanical

## Schematic

### PH9085.XXXNL and PM2185.XXXNL

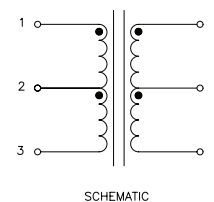
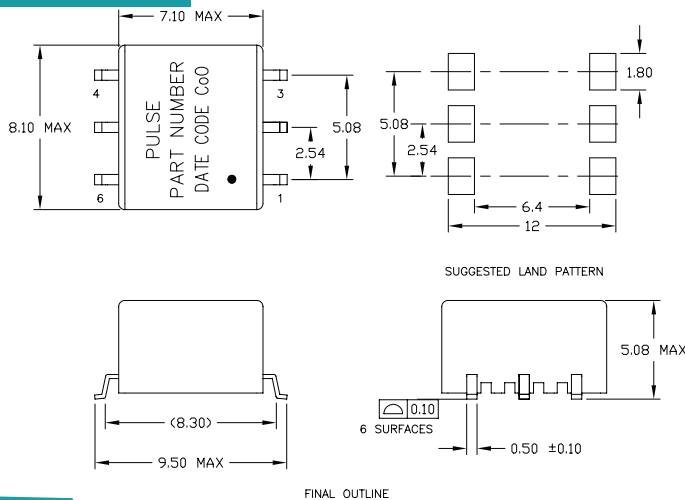

Weight .....0.365grams  
 Tape & Reel .....700/reel  
 Tray .....55/tray  
**Dimensions: mm**  
 Unless otherwise specified,  
 all tolerances are  $\pm 0.25$

# Isolation Power Transformers

Toroid Platform SMD PH9085.XXXNL and PM2180.XXXNL

## TAPE & REEL INFO

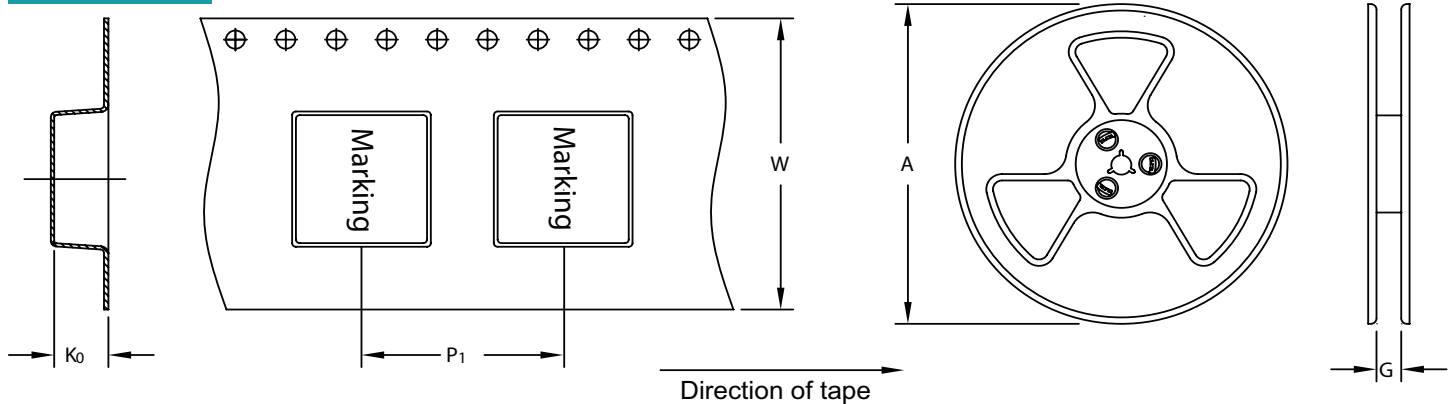

### SURFACE MOUNTING TYPE, REEL/TAPE LIST

PART NUMBER	REEL SIZE (mm)		TAPE SIZE (mm)			QTY
	A	G	P <sub>1</sub>	W	K <sub>0</sub>	PCS/REEL
PH9085.XXXNL/PM2180.XXXNL	Ø330	16.4	12	16	6.6	700

## APPLICATION

PH9085.XXXNL is a series of high isolation power supply transformer drivers. Intended to operate in a fixed duty cycle Push Pull topology, it is a part of a low cost solution for delivering lower power (up to 2W) from a low voltage source. A typical implementation would be an isolated RS-485/RS-232 power supply driver circuit, the design is compatible with the MAXIM™ MAX253 IC.

A schematic diagram for the Push Pull converter topology is given below.

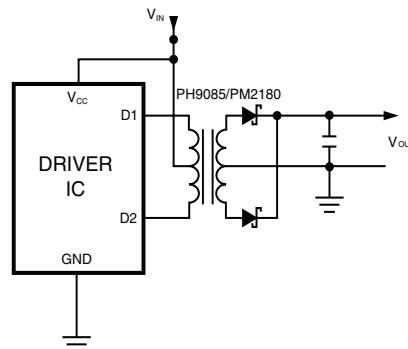

For a fixed 50% duty cycle mode of operation, the output voltage is simply determined by the input voltage and turns ratio. So, with the available turns ratios, a variety of output voltages can be selected.

MAXIM is a registered trademark of Maxim Integrated Products.

### For More Information

#### Pulse Worldwide Headquarters

15255 Innovation Drive Ste 100  
San Diego, CA 92128  
U.S.A.

#### Pulse Europe

Pulse Electronics GmbH  
Am Rottland 12  
58540 Meinerzhagen  
Germany

#### Pulse China Headquarters

Pulse Electronics (Shenzhen) CO., LTD  
D708, Shenzhen Academy of  
Aerospace Technology,  
The 10th Keji South Road,  
Nanshan District, Shenzhen,  
P.R. China 518057

#### Pulse North China

Room 2704/2705  
Super Ocean Finance Ctr.  
2067 Yan An Road West  
Shanghai 200336  
China

#### Pulse South Asia

3 Fraser Street  
0428 DUO Tower  
Singapore 189352

#### Pulse North Asia

1F., No.111 Xiyuan Rd  
Zhongli City  
Taoyuan City 32057  
Taiwan (R.O.C)

Tel: 858 674 8100  
Fax: 858 674 8262

Tel: 49 2354 777 100  
Fax: 49 2354 777 168

Tel: 86 755 33966678  
Fax: 86 755 33966700

Tel: 86 21 62787060  
Fax: 86 2162786973

Tel: 65 6287 8998  
Fax: 65 6280 0080

Tel: 886 3 4356768  
Fax: 886 3 4356820

Performance warranty of products offered on this data sheet is limited to the parameters specified. Data is subject to change without notice. Other brand and product names mentioned herein may be trademarks or registered trademarks of their respective owners. © Copyright, 2018. Pulse Electronics, Inc. All rights reserved.

单击下面可查看定价，库存，交付和生命周期等信息

[>>Pulse\(普思\)](#)