

Description:

100 Base-TX (Fast Ethernet) RJ45 1x1 Tab-DOWN with LEDs 8-pin (JO series) integrated magnetics connector (ICM), designed to support applications, such as SOHO (ADSL modems), LAN-on-Motherboard (LOM), Hub and Switches.

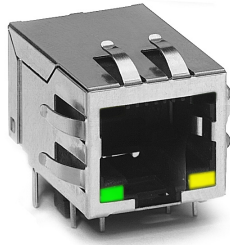

JO006D21BNL shown

Features and Benefits:

- Ⓢ RoHS peak wave solder temperature rating 260°C
- Ⓢ Suitable for CAT 5 & 6 Fast Ethernet Cable or better UTP

Electrical Performance Summary:

- Ⓢ Meets or exceeds IEEE 802.3 standard for 100Base-TX
- Ⓢ 350 µH minimum OCL with 8mA bias current
- Ⓢ Minimum 1500Vrms isolation per IEEE 802.3 requirement

Electrical Specifications @ 25°C — Operating Temperature 0°C to +70°C

RoHS Compliant Part Number	Turns Ratios		Mech. Drawing	EMI Fingers	LEDs ¹ (L/R)	Insertion Loss (dB TYP)	Return Loss (dB TYP) 100W ±15W					Crosstalk (dB TYP)			Common Mode Rejection (dB TYP)		Hipot (VDC)
	TX	RX					1-65 MHz	1-10 MHz	10-30 MHz	30-60 MHz	60-80 MHz	1-30 MHz	30-60 MHz	60-100 MHz	1-50 MHz	50-150 MHz	
JO006D01BNL	1CT:1	1CT:1	A	No	G/Y	-1	-20	-16	-12	-10	-40	-35	-30	-30	-20	2250	
JO006D21N1L	1CT:1	1CT:1	D	YES	N/A	-1	-20	-16	-12	-10	-40	-35	-30	-30	-20	2250	
JO006D21BNL	1CT:1	1CT:1	B	YES	G/Y	-1	-20	-16	-12	-10	-40	-35	-30	-30	-20	2250	
JO011D01N1L	1CT:1	1CT:1	C	No	N/A	-1	-20	-16	-12	-10	-40	-35	-30	-30	-20	2250	
JO011D01BNL	1CT:1	1CT:1	A	No	G/Y	-1	-20	-16	-12	-10	-40	-35	-30	-30	-20	2250	
JO011D21N1L	1CT:1	1CT:1	D	YES	N/A	-1	-20	-16	-12	-10	-40	-35	-30	-30	-20	2250	
JO011D21BNL	1CT:1	1CT:1	B	YES	G/Y	-1	-20	-16	-12	-10	-40	-35	-30	-30	-20	2250	
JO011D21E1N1L	1CT:1	1CT:1	B	YES	G/G	-1	-20	-16	-12	-10	-40	-35	-30	-30	-20	2250	
JO012D21N1L	1CT:1	1CT:1	D	YES	N/A	-1	-20	-16	-12	-10	-40	-35	-30	-30	-20	2250	
JO018D21N1L	1CT:1.414	1CT:1	D	YES	N/A	-1	-20	-16	-12	-10	-40	-35	-30	-30	-20	2250	
JO018D21E1N1L	1CT:1.414	1CT:1	B	YES	G/G	-1	-20	-16	-12	-10	-40	-35	-30	-30	-20	2250	
JO026D01N1L	1CT:1	1CT:1	C	No	N/A	-1	-20	-16	-12	-10	-40	-35	-30	-30	-20	2250	
JO026D01BNL	1CT:1	1CT:1	A	No	G/Y	-1	-20	-16	-12	-10	-40	-35	-30	-30	-20	2250	
JO026D01E1N1L	1CT:1	1CT:1	A	No	G/G	-1	-20	-16	-12	-10	-40	-35	-30	-30	-20	2250	
JO026D21N1L	1CT:1	1CT:1	D	YES	N/A	-1	-20	-16	-12	-10	-40	-35	-30	-30	-20	2250	
JO026D21BNL	1CT:1	1CT:1	B	YES	G/Y	-1	-20	-16	-12	-10	-40	-35	-30	-30	-20	2250	
JO026D21E1N1L	1CT:1	1CT:1	B	YES	G/G	-1	-20	-16	-12	-10	-40	-35	-30	-30	-20	2250	
JO026D21F1N1L ²	1CT:1	1CT:1	B	YES	G/Y	-1	-20	-16	-12	-10	-40	-35	-30	-30	-20	2250	
JO026D21G1N1L ³	1CT:1	1CT:1	B	YES	YG/G	-1	-20	-16	-12	-10	-40	-35	-30	-30	-20	2250	
JO0-0014N1L	1CT:1	1CT:1	C	No	N/A	-1	-20	-16	-12	-10	-40	-35	-30	-30	-20	2250	
JO0-0045N1L	1CT:1	1CT:1	A	No	G/Y	-1	-20	-16	-12	-10	-40	-35	-30	-30	-20	2250	
JO0-0061N1L	1CT:1	1CT:1	F	YES	N/A	-1	-20	-16	-12	-10	-40	-35	-30	-30	-20	2250	
JO0-0065N1L	1CT:1	1CT:1	E	YES	G/Y	-1	-20	-16	-12	-10	-40	-35	-30	-30	-20	2250	

Notes: 1. LEDs Left/right: G=green, Y=yellow, N/A=none, YG=Bi-color LED Yellow Green. 2. LEDs with internal resistor. 3. Bi-color Left LED.

RJ45 Durability Testing Rating

Part Number	Mating Force (MAX)	Unmating Force (MAX)	Durability	Plug to Jack Retention (MIN)
JO Series	5 lbs./2.268 kgs.	5 lbs./2.268 kgs.	750 Insertions	20 lbs./9.072 kgs.

RJ45 Material Specification

Part Number	Shield		Contact			Housing		MSL ³ Rating
	Material	Finish	Material	Plating Area	Solder Area ²	Material	Specification	
JO Series	Brass	10-20m inches Nickel over 10-20m inches Brass	Phosphor Bronze	Nickel underplating and selective gold plating 15µ inches	120µ inches Sn100 over 50µ inches nickel	Thermoplastic	UL 94 V-0	1

Notes: 1. Connector dimensions comply with FCC dimension requirements. 2. RoHS parts are tin matte finish over nickel. 3. MSL = Moisture Sensitivity Level rating from 1 to 5 (highest = 1, lowest = 5)

J0 Series Mechanicals

A

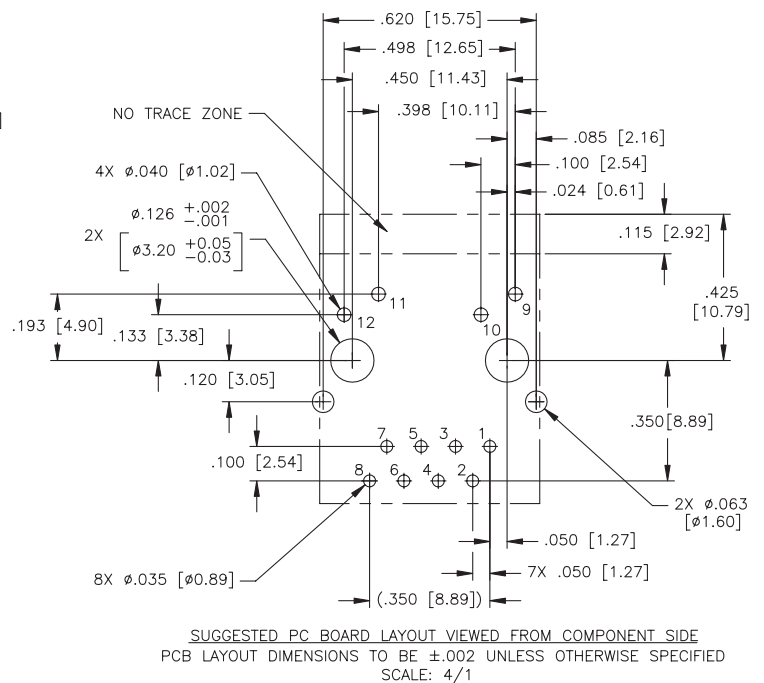
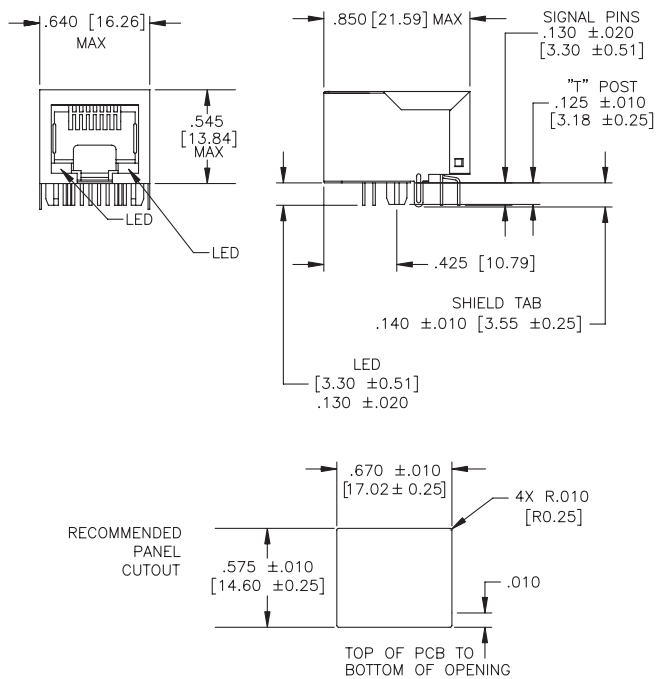

B

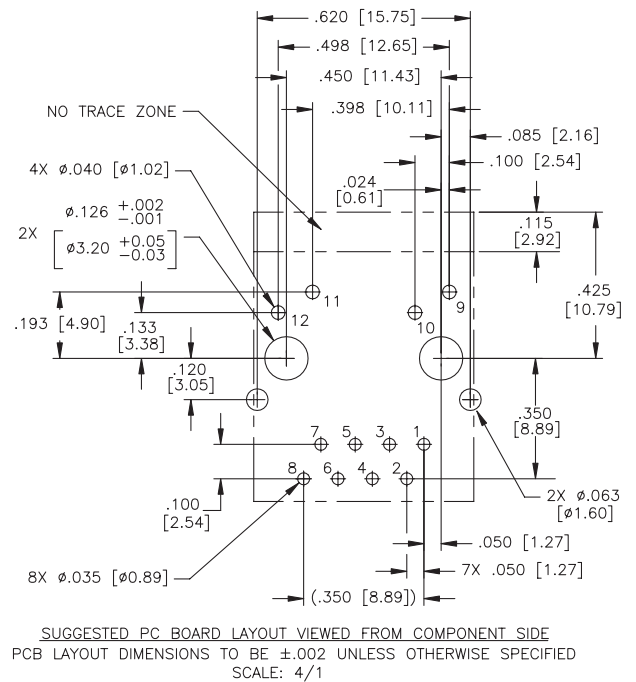
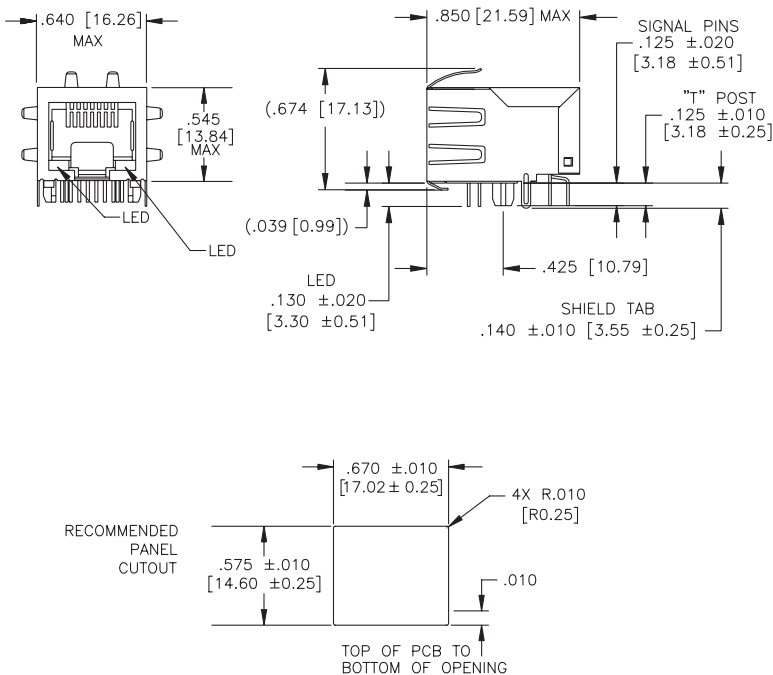

Dimensions: $\frac{\text{Inches}}{\text{mm}}$

Unless otherwise specified, all tolerances are ±.010/0.25

J0 Series Mechanicals (continued)

C

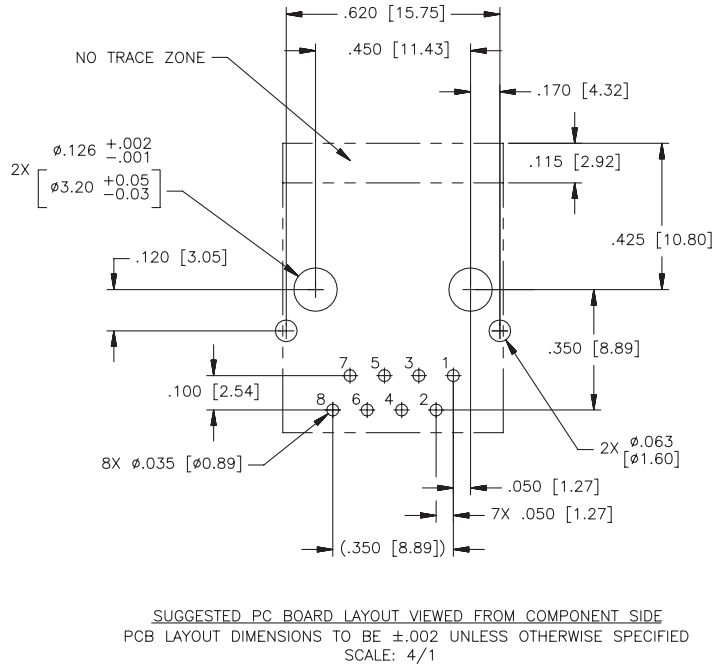
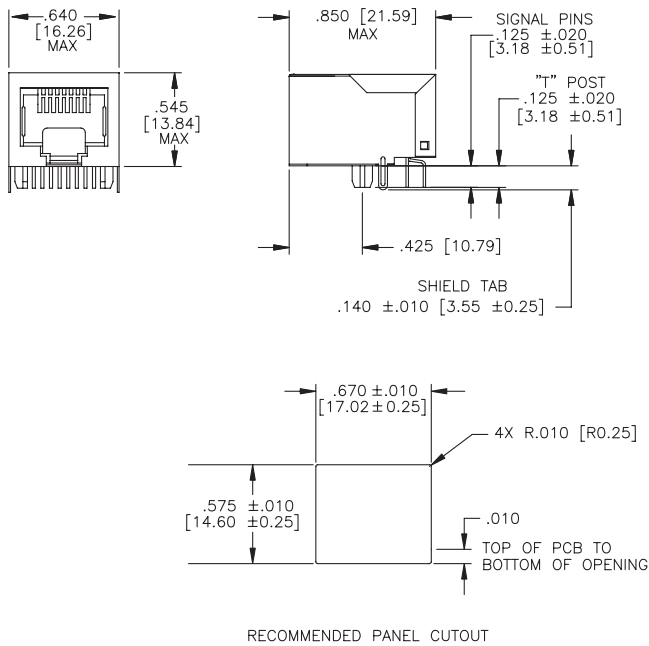

Dimensions: Inches
mm

Unless otherwise specified, all tolerances are ±.010 / 0.25

D

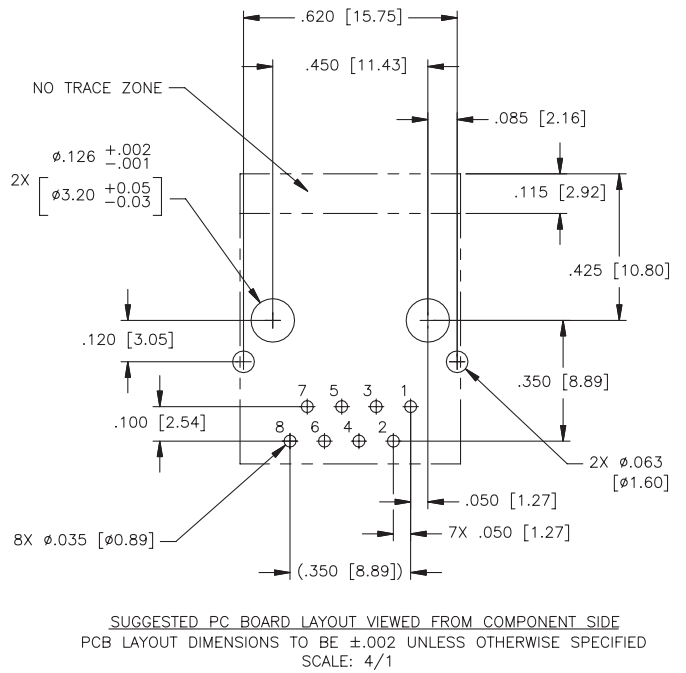
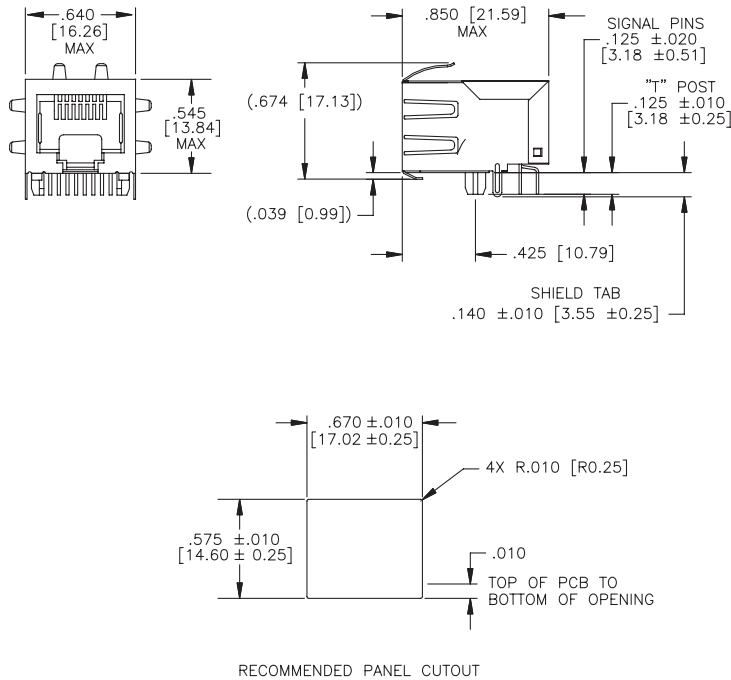

J0 Series Mechanicals (continued)

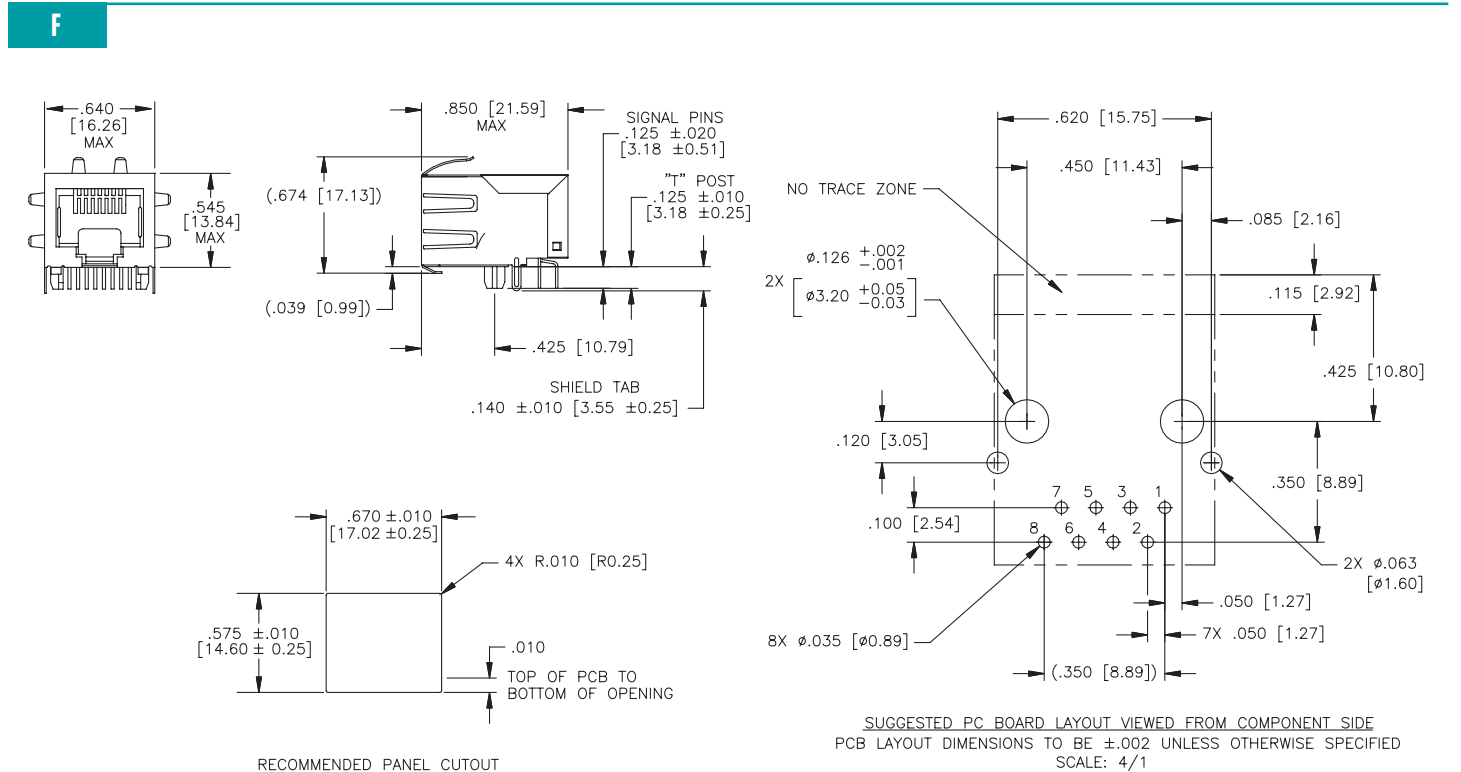
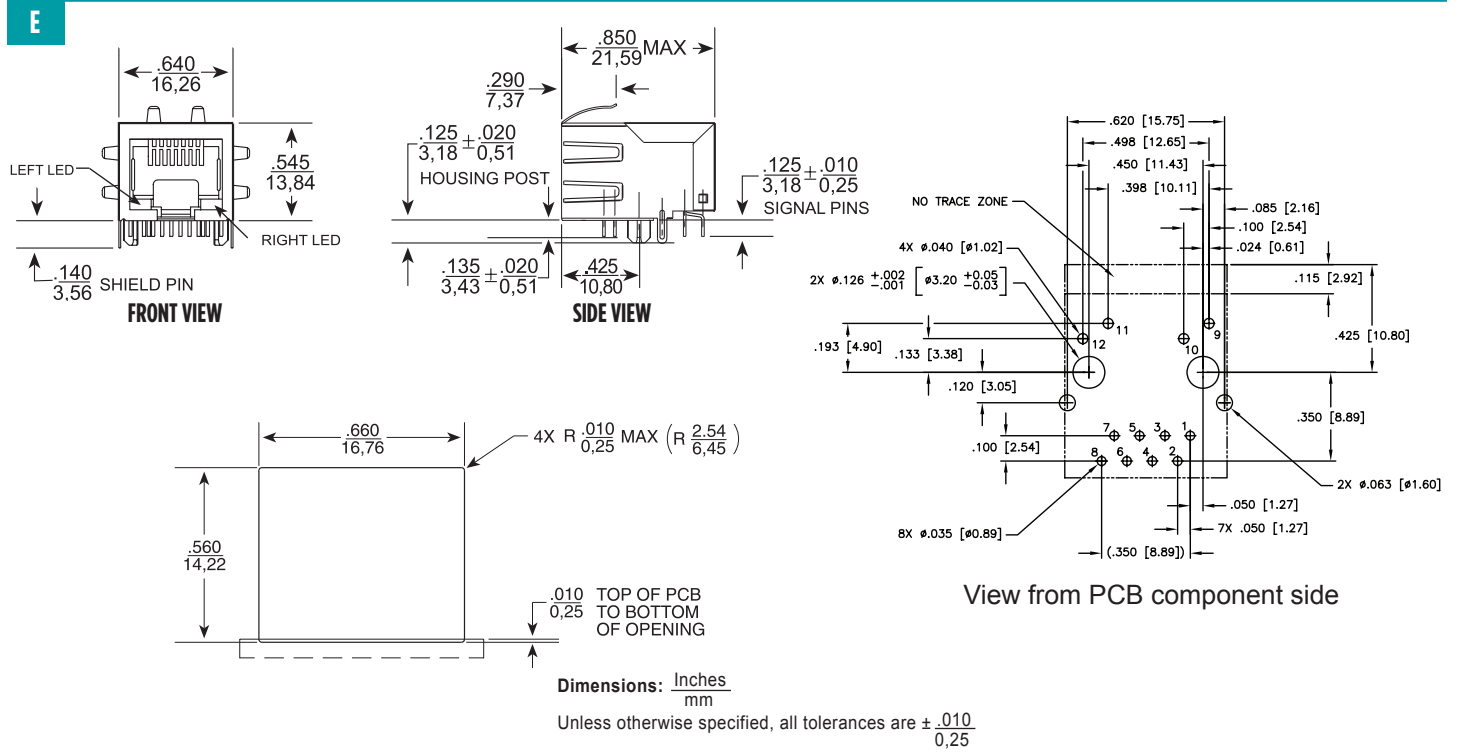

J0 Series Electrical Schematics

J0006

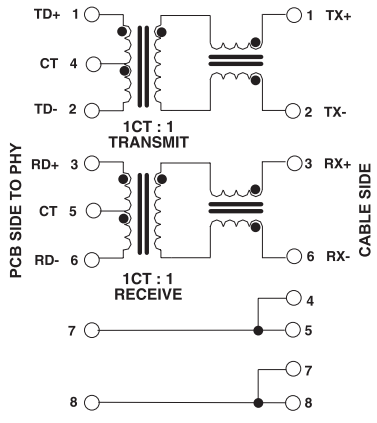

J0011/J00-0014NL/45NL/61NL/65NL

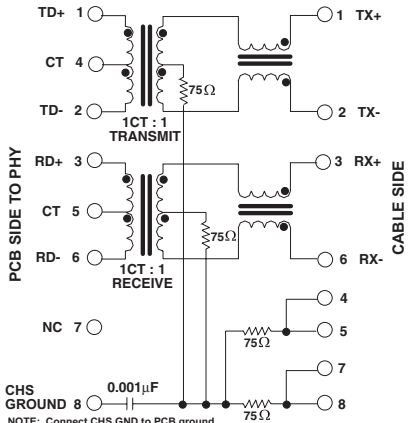

J0012

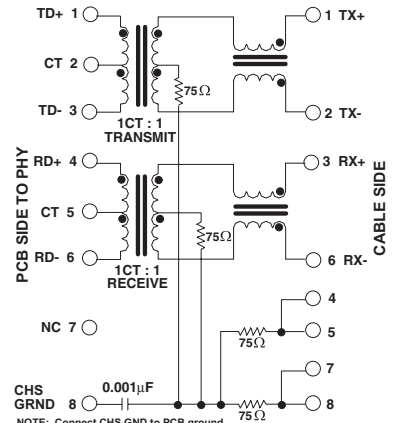

J0018

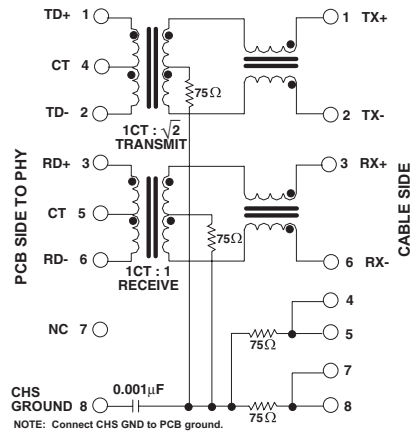

J0026

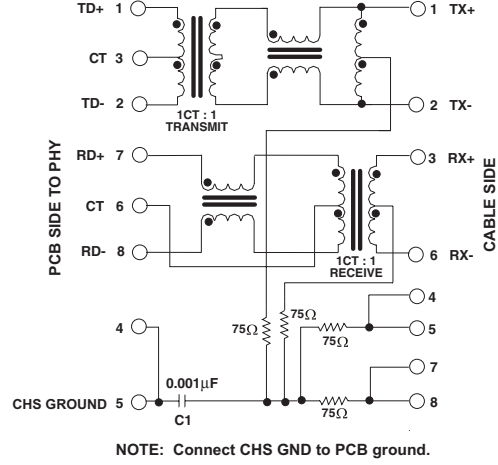

LED Configuration

LEDs without internal resistors

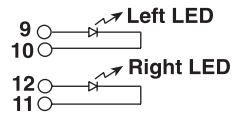

LEDs with internal resistors

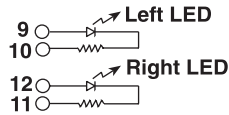

Bi-color LED option with internal resistors

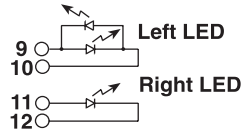

Standard LED	Wavelength	Forward* V(MAX)	(TYP)
Yellow	585 nm	2.5 V	2.1 V
Green	565 nm	2.5 V	2.2

* Using an internal resistor within the LED increases the voltage rating of the diode from 2.5 V to 5.0 V (assumes bias current = 20 mA).

For More Information:

Americas - prodinfonetworkamericas@pulseelectronics.com | Europe - comms-Apps-Europe@pulseelectronics.com | Asia - prodinfonetworkapac@pulseelectronics.com

Performance warranty of products offered on this data sheet is limited to the parameters specified. Data is subject to change without notice. Other brand and product names mentioned herein may be trademarks or registered trademarks of their respective owners. © Copyright, 2019. Pulse Electronics, Inc. All rights reserved.

单击下面可查看定价，库存，交付和生命周期等信息

[>>Pulse\(普思\)](#)