

3-Axis Single Chip Magnetic Sensor



QMC5883P

The QMC5883P is a three-axis magnetic sensor, which integrates magnetic sensors and signal condition ASIC into one silicon chip. This Land Grid Array package (LGA) is targeted for applications such as e-compass, map rotation, gaming and personal navigation in mobile and wearable devices.

The QMC5883P is based on state-of-the-art, high resolution, magneto-resistive technology. Along with the custom-designed 16-bit ADC ASIC, it offers the advantages of low noise, high accuracy, low power consumption, offset cancellation and temperature compensations. QMC5883P enables 1° to 2° compass heading accuracy. The I²C serial bus allows for easy interface.

The QMC5883P is in a 3.0x3.0x0.9mm³ surface mount 16-pin LGA package.

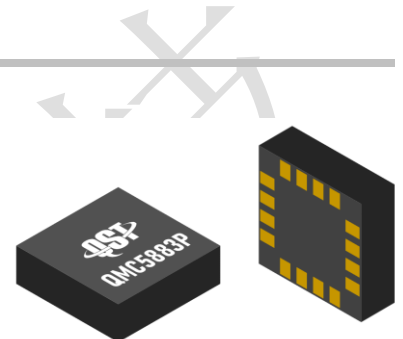

FEATURES

- ▶ 3-Axis Magneto-Resistive Sensors in a 3.0x3.0x0.9 mm³ LGA, Guaranteed to Operate Over an Extended Temperature Range of -40 °C to +85 °C.
- ▶ 16 Bit ADC With Low Noise AMR Sensors Achieves 2 milli-Gauss Field Resolution
- ▶ Wide Magnetic Field Range (±30 Gauss)
- ▶ Temperature Compensated Data Output
- ▶ I²C Interface with Standard and Fast Modes
- ▶ Built-In Self-Test
- ▶ Wide Range Operation Voltage (2.5V to 3.6V) and Low Power Consumption (35µA)
- ▶ Lead Free Package Construction
- ▶ Software and Algorithm Support Available

BENEFIT

- ▶ Small Size for Highly Integrated Products. Signals Have Been Digitized and Calibrated.
- ▶ Enables 1° To 2° Degree Compass Heading Accuracy, Allows for Pedestrian Navigation and LBS Applications
- ▶ Maximizes Sensor's Full Dynamic Range and Resolution
- ▶ Automatically Maintains Sensor's Sensitivity Under Wide Operating Temperature Range
- ▶ High-Speed Interfaces for Fast Data Communications. Maximum 1.5KHz Data Output Rate
- ▶ Enables Low-Cost Functionality Test After Assembly in Production
- ▶ Compatible with Battery Powered Applications
- ▶ RoHS Compliance
- ▶ Compassing Heading, Hard Iron, Soft Iron, and Auto Calibration Libraries Available

CONTENTS

CONTENTS.....	3
1 INTERNAL SCHEMATIC DIAGRAM.....	4
1.1 Internal Schematic Diagram.....	4
2 SPECIFICATIONS AND I/O CHARACTERISTICS.....	5
2.1 Product Specifications.....	5
2.2 Absolute Maximum Ratings.....	6
2.3 I/O Characteristics.....	6
3 PACKAGE PIN CONFIGURATIONS.....	6
3.1 Package 3-D View.....	6
3.2 Package Outlines.....	7
4 EXTERNAL CONNECTION.....	8
4.1 Recommended External Connection.....	8
4.2 Mounting Considerations.....	8
4.3 Layout Considerations.....	9
5 BASIC DEVICE OPERATION.....	9
5.1 Anisotropic Magneto-Resistive Sensors.....	9
5.2 Power Management.....	10
5.3 Power On/Off Time.....	10
5.4 Communication Bus Interface I ² C and Its Addresses.....	11
5.5 Internal Clock.....	11
5.6 Temperature Compensation.....	11
6 MODES OF OPERATION.....	11
6.1 Modes Transition.....	11
6.2 Description of Modes.....	11
7 APPLICATION EXAMPLES.....	12
7.1 Normal Mode Setup Example.....	12
7.2 Continuous Mode Setup Example.....	12
7.3 Self-test Example.....	12
7.4 Suspend Mode Example.....	12
7.5 Measurement Example.....	12
7.6 Soft Reset Example.....	12
8 I ² C COMMUNICATION PROTOCOL.....	13
8.1 I ² C Timings.....	13
8.2 I ² C R/W Operation.....	14
9 REGISTERS.....	15
9.1 Register Map.....	15
9.2 Register Definition.....	15

1 INTERNAL SCHEMATIC DIAGRAM

1.1 Internal Schematic Diagram

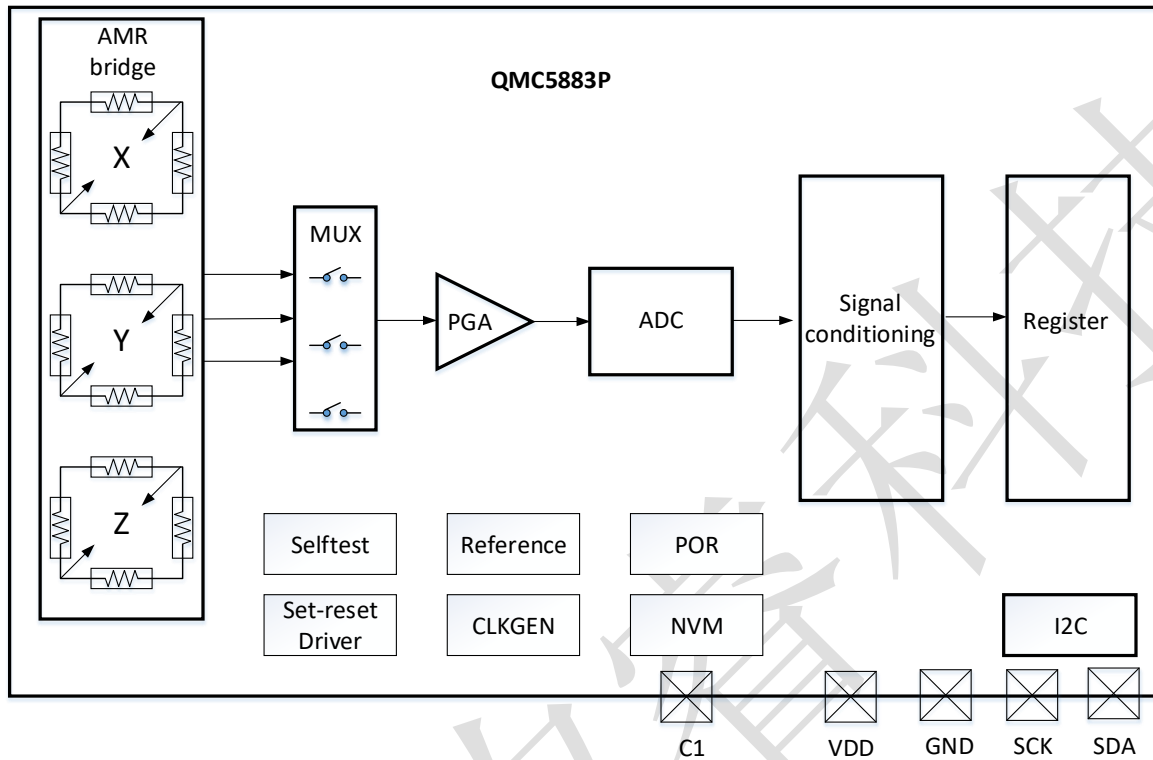

Figure 1. Block Diagram

Table 1. Block Function

Block	Function
AMR bridge	3-axis magnetic sensor
MUX	Multiplexer for sensor channels
PGA	Programmable gain amplifier for sensor signals
ADC	Analog-to-Digital converter
Signal conditioning	Digital blocks for magnetic signal calibration and compensations
I ² C	Interface logic data I/O
NVM	Non-volatile memory
Register	Internal register
Self test	Internal driver to generate self-test stimulus
Set-reset Driver	Internal driver to initialize magnetic sensor
Reference	Voltage/current reference for internal biasing
CLKGEN.	Internal oscillator for internal operation
POR	Power on reset

2 SPECIFICATIONS AND I/O CHARACTERISTICS

2.1 Product Specifications

Table 2. Specifications (Tested and specified at 25°C except stated otherwise.)

Parameter	Conditions	Min	Typ	Max	Unit
Supply Voltage	VDD	2.5		3.6	V
Suspend Mode Current	Total Current on VDD		22		μA
Normal Mode Current ^[1]	Low power and high power mode	ODR=10Hz	35/78		μA
		ODR=50Hz	85/310		
		ODR=100Hz	150/600		
		ODR=200Hz	280/1180		
Continuous Mode Current	Maximum ODR: 1500Hz		2200		μA
Sensor Field Range	Full Scale	-30		+30	Gauss
Sensitivity ^[2]	Field Range = ±30G		1000		LSB/G
	Field Range = ±12G		2500		LSB/G
	Field Range = ±8G		3750		LSB/G
	Field Range = ±2G		15000		LSB/G
Linearity	Field Range = ±30G Applied= ±15G		0.5		%FS
Hysteresis	3 sweeps across ±30G		0.03		%FS
Offset			±10		mG
Sensitivity Tempco	Ta = -40°C~85°C		±0.05		%/°C
Digital Resolution	Field Range = ±30G		1.0		mGauss
Field Resolution	Standard deviation	X/Y axis	2		mGauss
		Z axis	3		
X-Y-Z Orthogonality	Sensitivity Directions		90±1		Degree
Operating Temperature		-40		85	°C
ESD	HBM	4000			V
	CDM	1000			

Note [1]: The Normal Mode Current differs at different OSR1 setting. The value of low power mode is measured at OSR1=1 setting, and the value of high power mode is measured at OSR1=8.

Note [2]: Sensitivity is calibrated at zero field; it is slightly decreased at high fields.

2.2 Absolute Maximum Ratings

Table 3. Absolute Maximum Ratings (Tested at 25°C except stated otherwise.)

Parameter	MIN.	MAX.	Units
VDD	-0.3	5.4	V
Storage Temperature	-40	125	°C
Exposed to Magnetic Field (all directions)		50000	Gauss
Reflow Classification	MSL 1, 260 °C Peak Temperature		

2.3 I/O Characteristics

Table 4. I/O Characteristics (VDDIO=3.3V)

Symbol	Parameter(Units)	Minimum	Typical	Maximum
V _{IH}	High Level Input Voltage(V)	0.7*VDDIO		
V _{IL}	Low Level Input Voltage(V)			0.3*VDDIO
V _{HYS}	Hysteresis of Schmitt Trigger Input(V)	0.1		
I _{IL}	Input Leakage, ALL Inputs(uA)	-10		10
V _{OH}	High Level output Voltage(V)	0.8*VDDIO		
V _{OL}	Low Level output Voltage(V)			0.2*VDDIO

3 PACKAGE PIN CONFIGURATIONS

3.1 Package 3-D View

Arrow indicates direction of magnetic field that generates a positive output reading in normal measurement configuration.

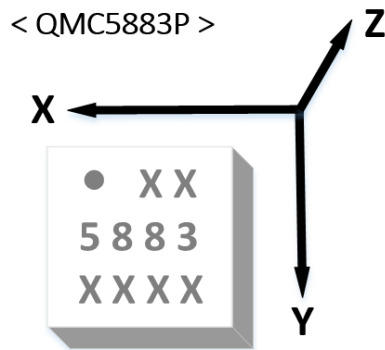

Figure 2. Package 3-D View

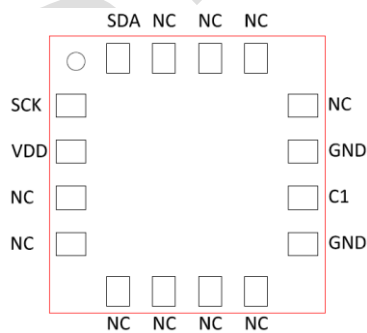

Figure 3. Package Top View

Table 5. Pin Configurations

<p>The information contained herein is the exclusive property of QST, and shall not be distributed, reproduced, or disclosed in whole or in part without prior written permission of QST.</p>	<p>6 / 18</p>
---	---------------

PIN No.	PIN NAME	I/O	TYPE	Function
1	SCK	I	CMOS	I2C clock
2	VDD		Power	Supply Power
3~8	NC		NC	Not connected
9	GND		VSS	Ground
10	C1		CMOS	Reservoir capacitor connection
11	GND		VSS	Ground
12~15	NC		NC	Not connected
16	SDA	I/O	CMOS	I2C data

3.2 Package Outlines

3.2.1 Package Type

LGA 16-pin

3.2.2 Package Size:

3.0mm (Length)*3.0mm (Width)*0.9mm (Height)

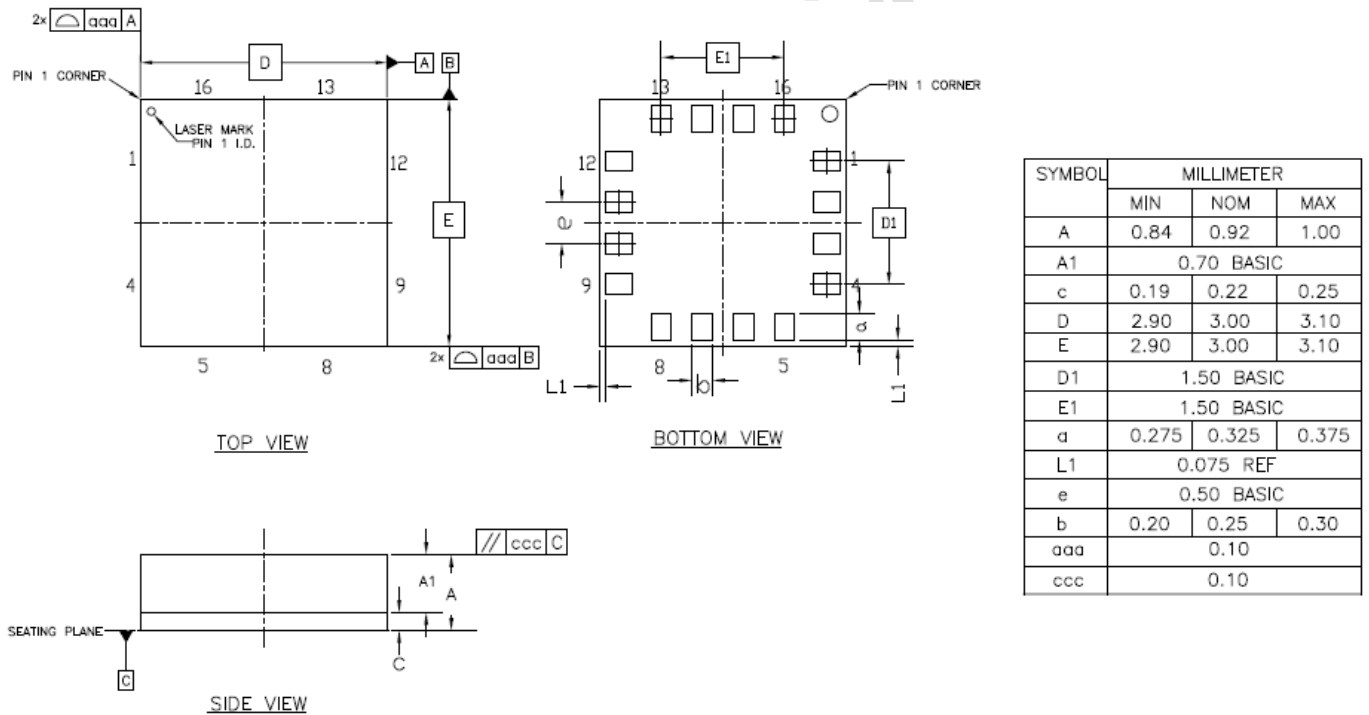
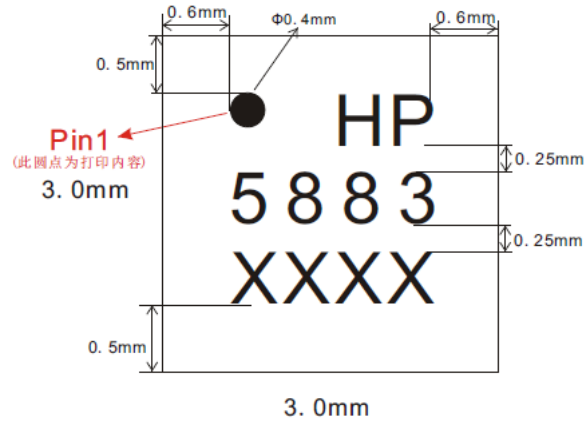

Figure 4. Package Size

3.2.3 Marking:

- H: supplier code; P:Fixed code, to denote QMC5883P
- 3rd line text: mass production trace-code
- = Pin1 Identifier

Figure 5. Chip Marking

4 EXTERNAL CONNECTION

4.1 Recommended External Connection

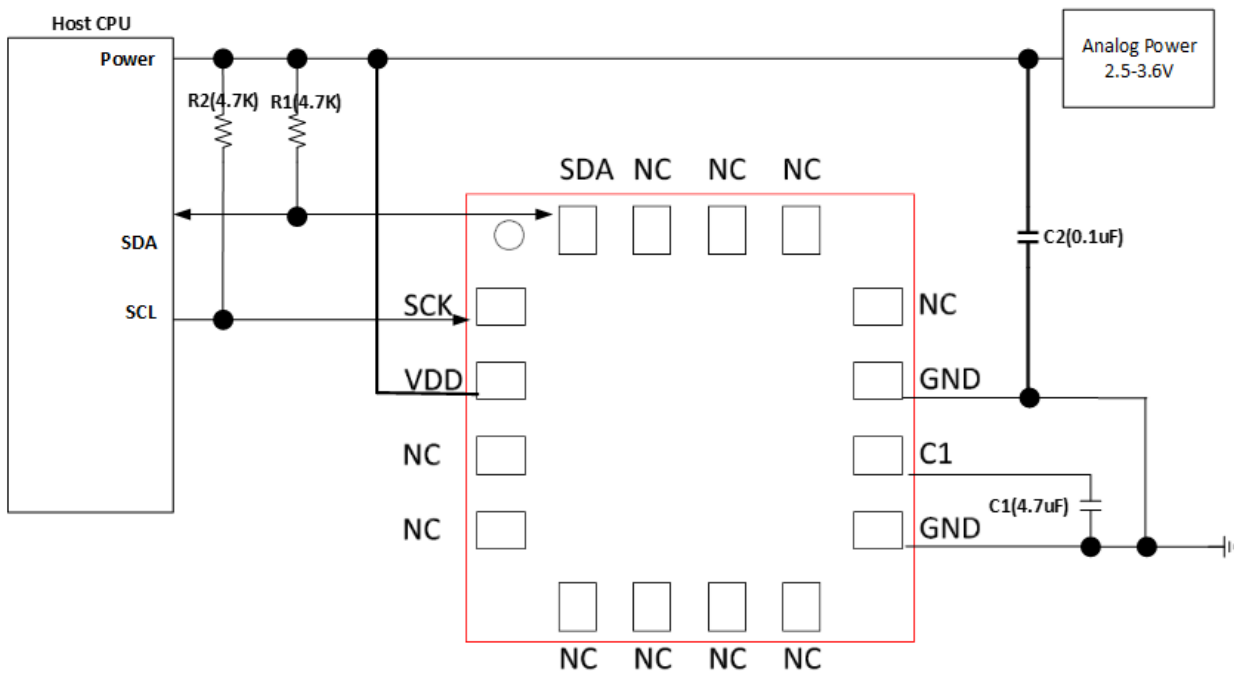
Figure 6. External Connection

Note: R1/R2 selection guide: 2.7Kohm for a short I2C bus length (less than 10 cm), and 4.7Kohm for a bus length less than 5 cm.

4.2 Mounting Considerations

The following is the recommend printed circuit board (PCB) footprint for the QMC5883P. Due to the fine pitch of the pads, the footprint should be properly centered in the PCB.

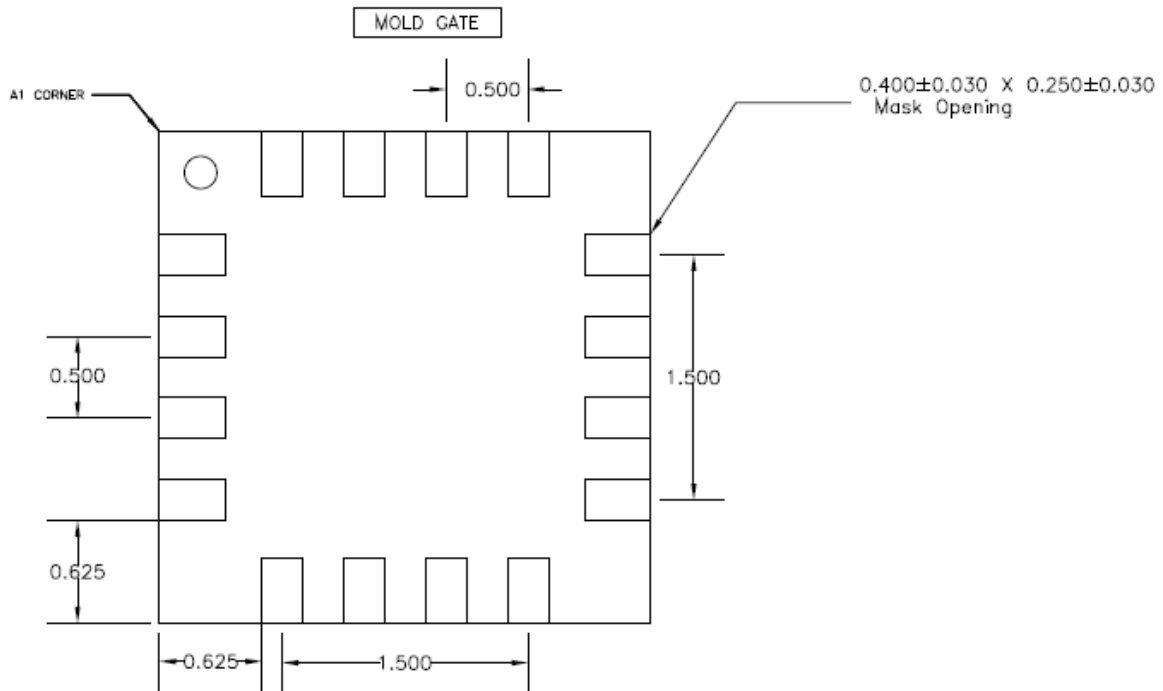

Figure 7. QMC5883P PCB footprint

4.3 Layout Considerations

Besides keeping all components that may contain ferrous materials (nickel, etc.) away from the sensor on both sides of the PCB, it is also recommended that there is no conducting copper line under/near the sensor in any of the PCB layers.

4.3.1 Solder Paste

A 4-mil stencil and 100% paste coverage is recommended for the electrical contact pads.

4.3.2 Reflow Assembly

This device is classified as MSL 3 with 260°C peak reflow temperature. As specified by JEDEC, parts with an MSL 3 rating require baking prior to soldering, if the part is not kept in a continuously dry (>10% RH) environment before assembly. Reference IPC/JEDEC standard J-STD-033 for additional information.

No special reflow profile is required for QMC5883P, which is compatible with lead eutectic and lead-free solder paste reflow profiles. QST recommends adopting solder paste manufacturer's guidelines. Hand soldering is not recommended.

4.3.3 External Capacitors

The external capacitors C1 should be ceramic type with low ESR characteristics. The exact ESR value is not critical, but values less than 200 milli-ohms are recommended. Reservoir capacitor C1 is nominally 4.7 μ F in capacitance. Low ESR characteristics may not be in many small SMT ceramic capacitors (0402), so be prepared to up-size the capacitors to gain low ESR characteristics.

5 BASIC DEVICE OPERATION

5.1 Anisotropic Magneto-Resistive Sensors

The QMC5883P magneto-resistive sensor circuit consists of tri-axial sensors and application specific support circuits to measure magnetic fields. With a DC power supply is applied to the sensor two terminals, the sensor converts any incident magnetic field in the sensitive axis directions to a differential voltage output.

The device has an offset cancellation function to eliminate sensor and ASIC offsets. It also applies a self-aligned magnetic field to restore magnetic state before each measurement to ensure high accuracy. Because of these features, the QMC5883P doesn't need to calibrate every time in most of application situations. It may need to be calibrated once in a new system or a system changes a new battery.

5.2 Power Management

There are only one power supply pins to the device. VDD provides power for all the internal analog and digital functional blocks and I/O.

When the device is powered on, all registers are reset by POR (Power-On-Reset), then the device transits to the suspend mode and waits for further commands.

Table 6 provides references for two power states.

Table 6: Power States

Power State	VDD	Power State description
1	0V	Device Off, No Power Consumption
2	2.5V~3.6V	Device On, Enters Suspend Mode after POR, waiting for further commands

5.3 Power On/Off Time

After the device is powered on, some time periods are required for the device fully functional. The external power supply requires a time period for voltage to ramp up (PSUP), it is typically 50 milli-second. However, it isn't controlled by the device. The Power-On-Reset time period (PORT) includes time to reset all the logics, load values in NVM to proper registers, enter the standby mode and get ready for analogy measurements. The power on/off time related to the device is in Table 7.

Table 7. Time Required for Power On/Off

Parameter	Symbol	Condition	Min.	Typ.	Max.	Unit
POR Completion Time	PORT	Time Period After VDD at Operating Voltage to Ready for I ² C Command			250	uS
Power off Voltage	SDV	Voltage that Device Considered to be Power Down.			0.2	V
Power on Interval	PINT	Time Period Required for Voltage Lower Than SDV to Enable Next POR	100			uS

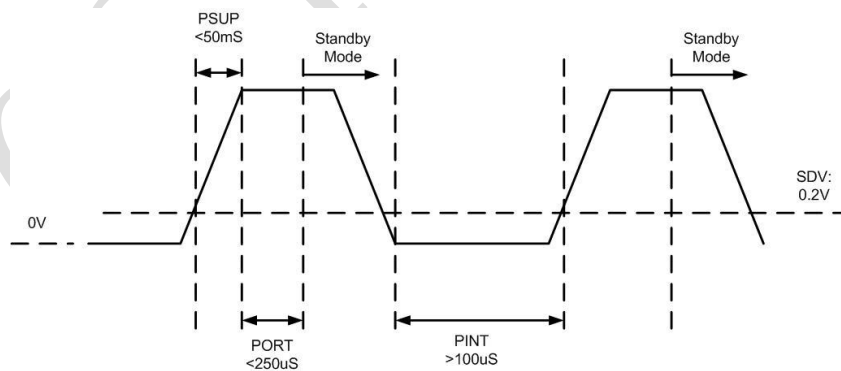

Power On/Off Timing

Figure 8. Power On/Off Timing

5.4 Communication Bus Interface I²C and Its Addresses

This device will be connected to a serial interface bus as a slave device under the control of a master device, such as the processor. Control of this device is carried out via I²C.

This device is compliant with I²C Bus Specification. As an I²C compatible device, this device has a 7-bit serial address and supports I²C protocols. This device supports standard and fast speed modes, 100kHz and 400kHz, respectively. External pull-up resistors are required to support all these modes.

The default I²C address for QMC5883P is 2CH.

If more I²C address options are required, please contact factory.

5.5 Internal Clock

The device has an internal clock for internal digital logic functions and timing management. This clock is not available to external usage.

5.6 Temperature Compensation

The Device has built-in Temperature compensation function. The compensated magnetic sensor data is placed in the Output Data Registers automatically.

6 MODES OF OPERATION

6.1 Modes Transition

The device has three different modes, controlled by register (0x0A), mode bits Mode<1:0>. The main purpose of these modes is for power management. The modes can be transitioned from one to another, as shown below, through I²C commands of changing mode bits. The default mode is Suspend Mode.

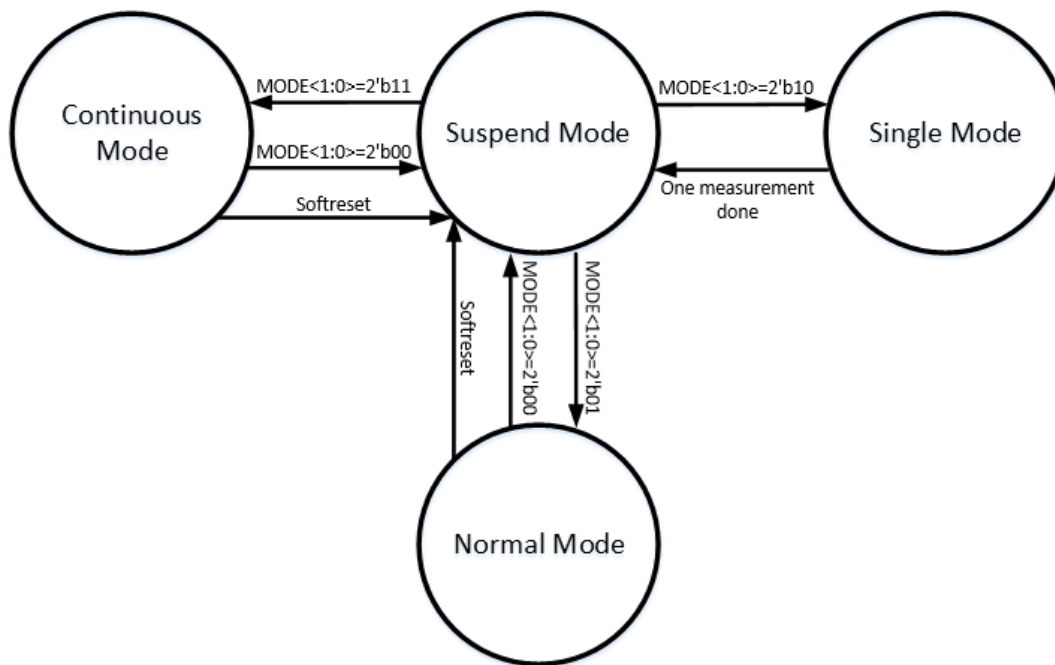

Figure 9. Modes Transition

6.2 Description of Modes

6.2.1 Normal Mode

During the Normal mode (MODE bits= 2'b01), the magnetic sensor continuously makes measurements and places measured data in data output registers. The field range register is controlled by RNG<1:0> in register 0BH and data output rate is controlled by ODR<1:0> in register 0AH. They should be set up properly for your applications in the normal mode.

6.2.2 Single Mode

During the Single Mode (MODE bits=2'b10), the whole chip runs only once and enter in the suspend mode after 1 measurement is finished.

6.2.3 Continuous Mode

During the Continuous Mode (MODE bits=2'b11), the whole chip runs all the time without sleep time, so the maximum ODR can be got at this mode. The self-test function can only be enabled in Continuous Mode and enters in Suspend Mode after the data is updated.

6.2.4 Suspend Mode

Suspend mode is the default magnetometer state upon POR and soft reset. Only few function blocks are activated in this mode which keeps power consumption as low as possible. In this state, register values are hold on by a lower power LDO, I2C interface is active and all register read and write are allowed. There is no magnetometer measurement in this Mode.

7 APPLICATION EXAMPLES

7.1 Normal Mode Setup Example

- ✧ Write Register 29H by 0x06 (Define the sign for X Y and Z axis)
- ✧ Write Register 0BH by 0x08 (Define Set/Reset mode, with Set/Reset On, Field Range 8Guass)
- ✧ Write Register 0AH by 0xCD (set normal mode, set ODR=200Hz)

7.2 Continuous Mode Setup Example

- ✧ Write Register 29H by 0x06 (Define the sign for X Y and Z axis)
- ✧ Write Register 0BH by 0x08 (Define Set/Reset mode, with Set/Reset On, Field Range 8Guass)
- ✧ Write Register 0AH by 0xC3 (set continuous mode)

7.3 Self-test Example

- ✧ Write Register 29H by 0x06 (Define the sign for X Y and Z axis)
- ✧ Write Register 0AH by 0x03 (set continuous mode)
- ✧ Check status register 09H[0] , "1" means ready
- ✧ Read data Register 01H ~ 06H, recording as datax1/datay1/dataz1
- ✧ Write Register 0BH by 0x40(enter self-test function)
- ✧ Waiting 5 millisecond until measurement ends
- ✧ Read data Register 01H ~ 06H, recording as datax2/datay2/dataz2
- ✧ Calculate the delta (datax1-datax2), (datay2-datay1), (dataz2-dataz1)

7.4 Suspend Mode Example

- ✧ Write Register 0AH by 0x00

7.5 Measurement Example

- ✧ Check status register 09H[0] , "1" means ready
- ✧ Read data register 01H ~ 06H

7.6 Soft Reset Example

- ✧ Write Register 0BH by 0x80

8 I²C COMMUNICATION PROTOCOL

8.1 I²C Timings

Below table and graph describe the I²C communication protocol times

Table 8. I²C Timings

Symbol	Parameter	Conditions	Standard-mode		Fast-mode		Unit
			Min	Max	Min	Max	
fSCL	SCL clock frequency		0	100	0	400	kHz
t _{HD;STA}	hold time (repeated) START condition	After this period, the first clock pulse is generated.	4.0		0.6		uS
t _{LOW}	LOW period of the SCL clock		4.7		1.3		uS
t _{HIGH}	HIGH period of the SCL clock		4.0		0.6		uS
t _{SU;STA}	set-up time for a repeated START condition		4.7		0.6		uS
t _{HD;DAT}	data hold time		0		0		uS
t _{SU;DAT}	data set-up time		250		100		nS
t _r	rise time of both SDA and SCL signals			300		300	nS
t _f	fall time of both SDA and SCL signals			300		300	nS
t _{SU;STO}	set-up time for STOP condition		4.0		0.6		uS
t _{BUF}	bus free time between a STOP and START condition		4.7		1.3		uS
C _b	capacitive load for each bus line			200		200	pF
t _{VD;DAT}	data valid time			0.8		0.8	uS
t _{VD;ACK}	data valid acknowledge time			0.8		0.8	uS

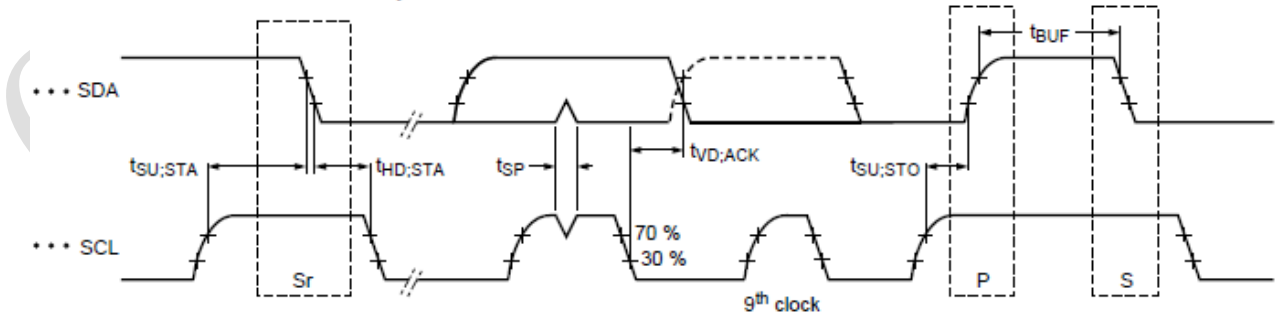
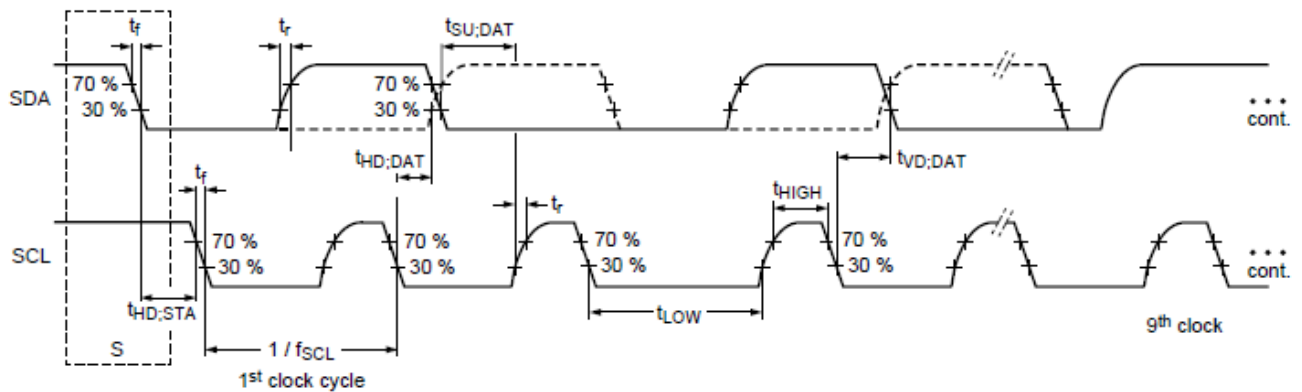

Figure 10. I²C Timing Diagram

8.2 I²C R/W Operation

8.2.1 Abbreviation

Table 9. Abbreviation

SACK	Acknowledged by slave
MACK	Acknowledged by master
NACK	Not acknowledged by master
RW	Read/Write

8.2.2 Start/Stop/Ack

START: Data transmission begins with a high to transition on SDA while SCL is held high. Once I²C transmission starts, the bus is considered busy.

STOP: STOP condition is a low to high transition on SDA line while SCL is held high.

ACK: Each byte of data transferred must be acknowledged. The transmitter must release the SDA line during the acknowledge pulse while the receiver must then pull the SDA line low so that it remains stable low during the high period of the acknowledge clock cycle.

NACK: If the receiver doesn't pull down the SDA line during the high period of the acknowledge clock cycle, it's recognized as NACK by the transmitter.

8.2.3 I²C Write

I²C write sequence begins with start condition generated by master followed by 7 bits slave address and a write bit (R/W=0). The slave sends an acknowledge bit (ACK=0) and releases the bus. The master sends the one-byte register address. The slave again acknowledges the transmission and waits for 8 bits data which shall be written to the specified register address. After the slave acknowledges the data byte, the master generates a stop signal and terminates the writing protocol.

Table 10. I²C Write for QMC5883P

START	Slave Address							R W	SACK	Register Address (0x0A)								SACK	Data (0x03)								SACK	STOP
	0	1	0	1	1	0	0	0		0	0	0	0	1	0	1	0		0	0	0	0	0	0	1	1		
	0	1	0	1	1	0	0	0	SACK	0	0	0	0	1	0	1	0	SACK	0	0	0	0	0	0	1	1	SACK	STOP

8.2.4 I²C Read

I²C read sequence consists of a one-byte I²C write phase followed by the I²C read phase. A start condition must be generated between two phases. The I²C write phase addresses the slave and sends the register address to be read. After slave acknowledges the transmission, the master generates again a start condition and sends the slave address together with a read bit (R/W=1). Then master releases the bus and waits for the data bytes to be read out from slave. After each data byte, the master has to generate an acknowledge bit (ACK = 0) to enable further data transfer. A NACK from the master stops the data being transferred from the slave. The slave releases the bus so that the master can generate a STOP condition and terminate the transmission.

Table 12. I²C Read for QMC5883P

START	Slave Address							R W	SACK	Register Address (0x00)								SACK	STOP
	0	1	0	1	1	0	0	0		0	0	0	0	0	0	0	0		
	0	1	0	1	1	0	0	0	SACK	0	0	0	0	0	0	0	0	SACK	STOP
START	Slave Address							R W	SACK	Data (0x80)								NACK	STOP
	0	1	0	1	1	0	0	1		1	0	0	0	0	0	0	0		
	0	1	0	1	1	0	0	1	SACK	1	0	0	0	0	0	0	0	NACK	STOP
	0	1	0	1	1	0	0	1	SACK	1	0	0	0	0	0	0	0	NACK	STOP

9 REGISTERS

9.1 Register Map

The table below provides a list of the 8-bit registers embedded in the device and their respective function and addresses

Table 14. Register Map

Addr.	7	6	5	4	3	2	1	0	Access
00H	CHIPID[7:0]								Read only
01H	Data Output X LSB Register XOUT[7:0]								Read only
02H	Data Output X MSB Register XOUT[15:8]								Read only
03H	Data Output Y LSB Register YOUT[7:0]								Read only
04H	Data Output Y MSB Register YOUT[15:8]								Read only
05H	Data Output Z LSB Register ZOUT[7:0]								Read only
06H	Data Output Z MSB Register ZOUT[15:8]								Read only
09H	RFU						OVFL	DRDY	Read only
0AH	OSR2<1:0>		OSR1<1:0>		ODR<1:0>		MODE<1:0>		Read/Write
0BH	SOFT_ RST	SELF_ TEST	RFU			RNG<1:0>		SET/RESET MODE<1:0>	Read/Write

9.2 Register Definition

9.2.1 Output Data Register

Register 00H stores the chip ID. The default value is 80H.

Registers 01H ~ 06H store the measurement data from each axis magnetic sensor in each working mode. In the normal mode, the output data is refreshed periodically based on the data update rate ODR setup in control registers 0AH. The data stays the same, regardless of reading status through I²C, until new data replaces them. Each axis has 16-bit data width in 2's complement, i.e., MSB of 02H/04H/06H indicates the sign of each axis. The output data of each channel saturates at -32768 and 32767.

Table 15. Output Data Register

Addr.	7	6	5	4	3	2	1	0
00H	CHIPID[7:0]							
01H	Data Output X LSB Register XOUT[7:0]							
02H	Data Output X MSB Register XOUT[15:8]							
03H	Data Output Y LSB Register YOUT[7:0]							
04H	Data Output Y MSB Register YOUT[15:8]							
05H	Data Output Z LSB Register ZOUT[7:0]							
06H	Data Output Z MSB Register ZOUT[15:8]							

9.2.2 Status Register

There is one status register located in address 09H.

Register 09H has two bits indicating for status flags, the rest are reserved for factory use. The status registers are read only bits.

Table 16. Status Register 1

Addr.	7	6	5	4	3	2	1	0
09H							OVFL	DRDY

Data Ready Register (DRDY), it is set when all three-axis data is ready and loaded to the output data registers in each mode. It is reset to "0" by reading the status register through I²C commands

DRDY: "0": no new data, "1": new data is ready

OVFL bit set high when either axis code output exceeds the range of [-30000,30000] LSB and reset to “0” after this bit is read.

OVFL: “0”: no data overflow occurs, “1”: data overflow occurs.

9.2.3 Control Registers

Two 8-bits registers are used to control the device configurations.

Control register 1 is located in address 0AH, it sets the operational modes (MODE) and over sampling rate (OSR). Control register 2 is located in address 0BH. It controls soft reset, self-test and set/reset mode.

Two bits of MODE registers can transfer mode of operations in the device, the four modes are Suspend Mode, Normal mode, Single Mode and Continuous Mode. The default mode after Power-On-Reset (POR) is Suspend Mode. Suspend Mode should be added in the middle of mode shifting between Continuous Mode、Single Mode and Normal Mode.

The Output data rate is controlled by ODR registers. Four data update frequencies can be selected: 10Hz, 50Hz, 100Hz or 200Hz.

Over sample Rate (OSR1) registers are used to control bandwidth of an internal digital filter. Larger OSR value leads to smaller filter bandwidth, less in-band noise and higher power consumption. It could be used to reach a good balance between noise and power. Four over sample ratios can be selected, 8,4,2 or 1.

Another filter is added for better noise performance; the depth can be adjusted through OSR2.

Table 17. Control Register 1

Addr	7	6	5	4	3	2	1	0
0AH	OSR2<1:0>		OSR1<1:0>		ODR<1:0>		MODE<1:0>	
Reg.	Definition		00	01	10	11		
Mode	Mode Control		Suspend	Normal Mode	Single	Continuous Mode		
ODR	Output Data Rate		10Hz	50Hz	100Hz	200Hz		
OSR1	Over sample Ratio1		8	4	2	1		
OSR2	Down sampling rate		1	2	4	8		

Set/Reset Mode can be control by the register SET/RESET MODE. There are 3 modes for selection: SET AND RESET ON, SET ONLY ON and SET AND RESET OFF. In SET ONLY ON or SET AND RESET OFF mode, the offset is not renewed during measuring.

Field ranges of the magnetic sensor can be selected through the register RNG. The full-scale range is determined by the application environments. The lowest field range has the highest sensitivity, therefore, higher resolution.

Self-test function is added for verification of the signal-chain. When the function is enabled through the bit SELF_TEST, an inner-built current is generated and an additional signal is added to the sensor, generating a difference in the 3 axis' value. User should record the value before and after the self-test and compare with threshold value.

Soft Reset can be done by changing the register SOFT_RST. Soft reset can be invoked at any time of any mode.

Table 18. Control Register 2

Addr.	7	6	5	4	3	2	1	0
0BH	SOFT_RST	SELF_TEST	-	-	RNG<1:0>		SET/RESET MODE<1:0>	
Reg.	Definition		00	01	10		11	

SET/RESET MODE	Set and reset mode ctrl	Set and reset on	Set only on	Set and reset off	Set and reset off
RNG	Full Range	30Guass	12Guass	8Guass	2Guass
SELF_TEST	Self_test	1: self_test enable, auto clear after the data is updated			
SOFT_RST	Soft reset	1: Soft reset, restore default value of all registers, 0: no reset			

QST 钰家科技

ORDERING INFORMATION

Ordering Number	Operating Temperature	Package	Packaging
QMC5883P-TR	-40°C ~ 85°C	LGA-16	Tape and Reel: 3k pieces/reel

Caution

This part is sensitive to damage by electrostatic discharge. Use ESD precautionary procedures when touching, removing or inserting.

CAUTION: ESDS CAT. 1B

FIND OUT MORE

For more information on QST's Magnetic Sensors contact us at 86-21-69517300.

The application circuits herein constitute typical usage and interface of QST product. QST does not provide warranty or assume liability of customer-designed circuits derived from this description or depiction.

QST reserves the right to make changes to improve reliability, function or design. QST does not assume any liability arising out of the application or use of any product or circuit described herein; neither does it convey any license under its patent rights nor the rights of others.

U.S. Patents 4,441,072, 4,533,872, 4,569,742, 4,681,812, 4,847,584 and 6,529,114 apply to the technology described.

China Patents 201210563667.3, 201210563956.3, 201210563952.5, 201210563687.0, 201310403912.9, 201410027189.3, 201410027240.0, 201410027085.2 and 201410085278.3 apply to the technology described.

单击下面可查看定价，库存，交付和生命周期等信息

[>>qst](#)