



RF360
Europe GmbH

SAW Components

SAW Duplexer

Cellular/ WCDMA Band 5

Series/type:	B8576
Ordering code:	B39881B8576P810
Date:	September 23, 2015
Version:	2.2

RF360 products mentioned within this document are products of RF360 Europe GmbH and other subsidiaries of RF360 Holdings Singapore Pte. Ltd. (collectively, the "RF360 Subsidiaries").

RF360 Europe GmbH, Anzinger Str. 13, München, Germany

© 2019 RF360 Europe GmbH and/or its affiliated companies. All rights reserved.

These materials, including the information contained herein, may be used only for informational purposes by the customer. The RF360 Subsidiaries assume no responsibility for errors or omissions in these materials or the information contained herein. The RF360 Subsidiaries reserve the right to make changes to the product(s) or information contained herein without notice. The materials and information are provided on an AS IS basis, and the RF360 Subsidiaries assume no liability and make no warranty or representation, either expressed or implied, with respect to the materials, or any output or results based on the use, application, or evaluation of such materials, including, without limitation, with respect to the non-infringement of trademarks, patents, copyrights or any other intellectual property rights or other rights of third parties.

No use of this documentation or any information contained herein grants any license, whether express, implied, by estoppel or otherwise, to any intellectual property rights, including, without limitation, to any patents owned by QUALCOMM Incorporated or any of its subsidiaries.

Not to be used, copied, reproduced, or modified in whole or in part, nor its contents revealed in any manner to others without the express written permission of RF360 Europe GmbH.

Qualcomm is a trademark of Qualcomm Incorporated, registered in the United States and other countries. Other product and brand names may be trademarks or registered trademarks of their respective owners.

This technical data may be subject to U.S. and international export, re-export, or transfer ("export") laws. Diversion contrary to U.S. and international law is strictly prohibited.

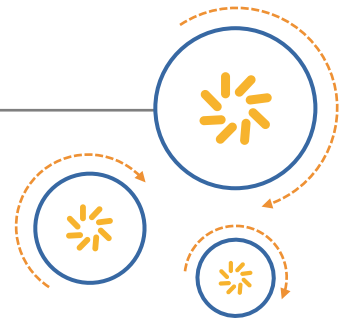

RF360 Europe GmbH

A Qualcomm – TDK Joint Venture

SAW Components

SAW Duplexer

Cellular/ WCDMA Band 5

Series/type:	B8576
Ordering code:	B39881B8576P810
Date:	September 23, 2015
Version:	2.2

RF360 products mentioned within this document are offered by RF360 Europe GmbH and other subsidiaries of RF360 Holdings Singapore Pte. Ltd. (collectively, the “RF360 Subsidiaries”). RF360 Holdings Singapore Pte. Ltd. is a joint venture of Qualcomm Global Trading Pte. Ltd. and EPCOS AG. References in this documentation to EPCOS AG should properly reference, and shall be read to reference, the RF360 Subsidiaries.

RF360 Europe GmbH, Anzinger Str. 13, München, Germany

© 2016 RF360 Europe GmbH and/or its affiliated companies. All rights reserved.

These materials, including the information contained herein, may be used only for informational purposes by the customer. The RF360 Subsidiaries assume no responsibility for errors or omissions in these materials or the information contained herein. The RF360 Subsidiaries reserve the right to make changes to the product(s) or information contained herein without notice. The materials and information are provided on an AS IS basis, and the RF360 Subsidiaries assume no liability and make no warranty or representation, either expressed or implied, with respect to the materials, or any output or results based on the use, application, or evaluation of such materials, including, without limitation, with respect to the non-infringement of trademarks, patents, copyrights or any other intellectual property rights or other rights of third parties.

No use of this documentation or any information contained herein grants any license, whether express, implied, by estoppel or otherwise, to any intellectual property rights, including, without limitation, to any patents owned by QUALCOMM Incorporated or any of its subsidiaries.

Not to be used, copied, reproduced, or modified in whole or in part, nor its contents revealed in any manner to others without the express written permission of RF360 Europe GmbH.

Qualcomm and Qualcomm RF360 are trademarks of Qualcomm Incorporated, registered in the United States and other countries. RF360 is a trademark of Qualcomm Incorporated. Other product and brand names may be trademarks or registered trademarks of their respective owners.

This technical data may be subject to U.S. and international export, re-export, or transfer ("export") laws. Diversion contrary to U.S. and international law is strictly prohibited.



SAW Components

SAW Duplexer

Cellular/ WCDMA Band 5

Series/type:	B8576
Ordering code:	B39881B8576P810
Date:	September 23, 2015
Version:	2.2

© EPCOS AG 2015. Reproduction, publication and dissemination of this data sheet, enclosures hereto and the information contained therein without EPCOS' prior express consent is prohibited.

EPCOS AG is a TDK Group Company.

Data sheet

Table of contents

1 Application	3
2 Features	3
3 Package	4
4 Pin configuration	4
5 Matching circuit	5
6 Characteristics	6
7 Maximum ratings	11
8 Transmission coefficients	12
9 Reflection coefficients	15
10 Packing material	16
11 Marking	19
12 Soldering profile	21
13 Annotations	22
14 Cautions and warnings	22
Contact and Important notes	23

Data sheet

1 Application

- Multimode SAW duplexer for mobile telephone Cellular / WCDMA Band 5 systems.
- Low insertion attenuation.
- Low amplitude ripple.
- High Tx band isolation.
- Single ended to balanced transformation in Antenna - Rx path.
- Impedance transformation from 50Ω to 100Ω in Antenna - Rx path.

2 Features

- Package size 1.8 mm × 1.4 mm.
- Max. package height 0.475 mm.
- Approximate weight 0.0042 g.
- RoHS compatible.
- Package for Surface Mount Technology (SMT).
- Ni, Au-plated terminals.
- Electrostatic Sensitive Device (ESD).
- Moisture Sensitivity Level 3 (MSL3).



Figure 1: Picture of component with example of marking.

Data sheet

3 Package

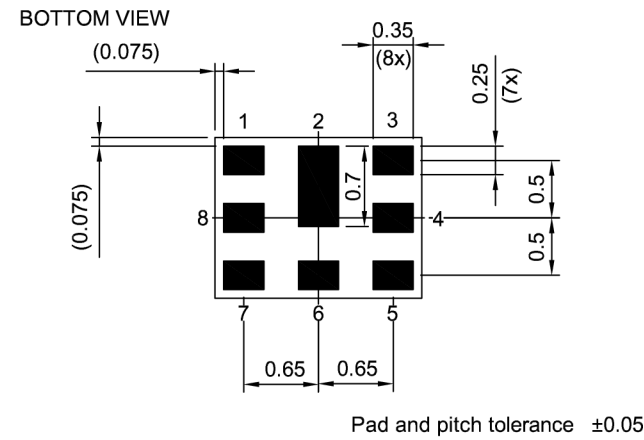

SIDE VIEW

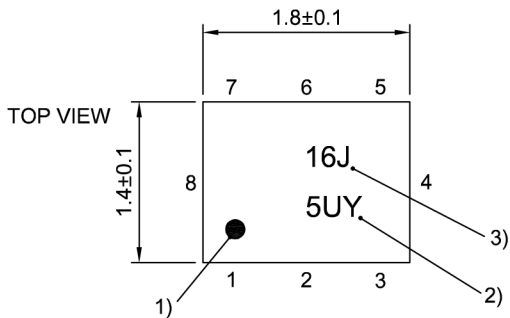
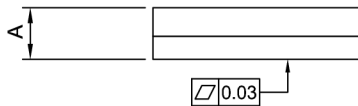

- 1) Marking for pad number 1
- 2) Example of encoded lot number
- 3) Example of encoded filter type number

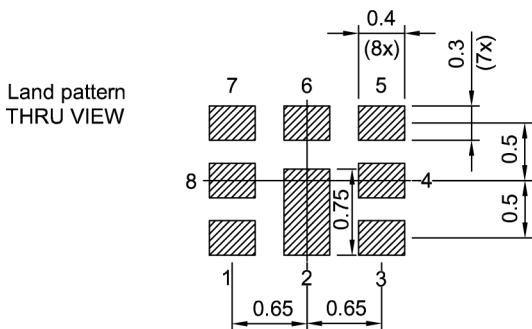

4 Pin configuration

- 1, 8 RX balanced
- 3 TX
- 6 ANT
- 2, 4, 5, 7 Ground

Figure 2: Drawing of package with package height A = 0.475 mm (max.). See Simplified drawings (p. 23).

Data sheet

5 Matching circuit

- $L_{p6} = 8.2 \text{ nH}$

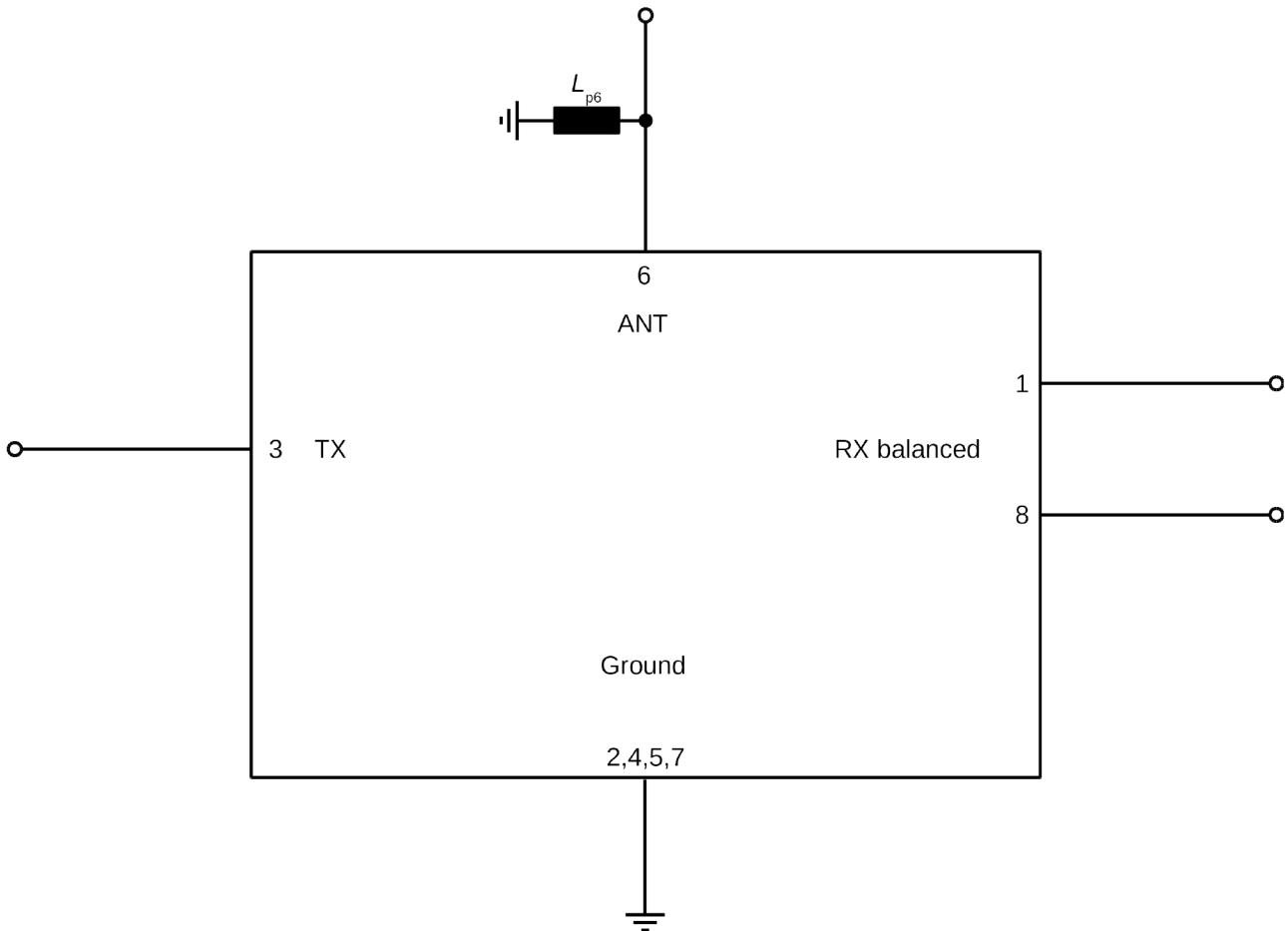

Figure 3: Schematic of matching circuit.

SAW Components	B8576
SAW Duplexer	836.5 / 881.5 MHz

Data sheet

6 Characteristics

6.1 TX – ANT

Temperature range for specification	T	= -30 °C to +90 °C
TX terminating impedance	Z_{TX}	= 50 Ω
ANT terminating impedance	Z_{ANT}	= 50 Ω with par. 8.2 nH
RX terminating impedance	Z_{RX}	= 100 Ω (balanced)

Characteristics TX – ANT			min.	typ. @+25 °C	max.	
Center frequency	f_C		—	836.5	—	MHz
Maximum insertion attenuation						
		824... 849 MHz	α_{max}	1.5	2.3	dB
	@ $f_{carrier}$	826.4... 846.6 MHz	$\alpha_{WCDMA,max}^{1)}$	1.3	2.1	dB
Amplitude ripple (p-p)						
		824... 849 MHz	$\Delta\alpha$	0.6	1.4	dB
Maximum error vector magnitude						
		826.4... 846.6 MHz	$EVM_{max}^{2)}$	2.1	4.0	%
Maximum VSWR						
		824... 849 MHz	$VSWR_{max}$	1.5	2.0	
		824... 849 MHz	$VSWR_{max}$	1.4	2.0	
Minimum attenuation						
		10... 420 MHz	α_{min}	40	45	dB
		420... 494 MHz	α_{min}	38	42	dB
		494... 701 MHz	α_{min}	35	39	dB
		701... 728 MHz	α_{min}	35	40	dB
		728... 764 MHz	α_{min}	35	41	dB
		764... 804 MHz	α_{min}	30	37	dB
		860... 869 MHz	α_{min}	3	10	dB
		869... 894 MHz	α_{min}	45	52	dB
	@ $f_{carrier}$	871.4... 891.6 MHz	$\alpha_{WCDMA,min}^{1)}$	48	53	dB
		1236... 1341 MHz	α_{min}	40	47	dB
		1574... 1577 MHz	α_{min}	35	39	dB
		1638... 1708 MHz	α_{min}	33	36	dB
		1844.9... 1879.9 MHz	α_{min}	30	34	dB
		1884.5... 1919.6 MHz	α_{min}	30	34	dB

Data sheet

Characteristics TX – ANT				min.	typ. @+25 °C	max.	
	1930... 1990	MHz	α_{min}	30	33	—	dB
	2110... 2170	MHz		28	31	—	dB
	2400... 2557	MHz		25	28	—	dB
	3286... 3406	MHz		20	25	—	dB
	4110... 4255	MHz		20	24	—	dB
	4934... 5350	MHz		10	14	—	dB
	5725... 5953	MHz		5	10	—	dB

¹⁾ Attenuation of WCDMA signal ("power transfer function"). Please refer to definition of Power Transfer Function (PTF) of WCDMA signal (p. 22).

²⁾ Error Vector Magnitude (EVM) based on definition given in 3GPP TS 25.141.

SAW Components	B8576
SAW Duplexer	836.5 / 881.5 MHz

Data sheet

6.2 ANT – RX

Temperature range for specification	T	= -30 °C to +90 °C
TX terminating impedance	Z_{TX}	= 50 Ω
ANT terminating impedance	Z_{ANT}	= 50 Ω with par. 8.2 nH
RX terminating impedance	Z_{RX}	= 100 Ω (balanced)

Characteristics ANT – RX	min.	typ. @+25 °C	max.	
Center frequency	—	881.5	—	MHz
Maximum balanced insertion attenuation				
869... 894 MHz	—	1.7	2.4	dB
@ $f_{carrier}$ 871.4... 891.6 MHz	—	1.5	2.2	dB
Amplitude ripple (p-p)				
869... 894 MHz	—	0.5	1.2	dB
Maximum error vector magnitude				
871.4... 891.6 MHz	—	1.7	3.5	%
Maximum VSWR				
@ ANT port	—	1.7	2.0	
@ RX port	—	1.6	2.0	
Minimum common-mode rejection ratio				
869... 894 MHz	23	27	—	dB
Minimum balanced attenuation				
10... 447 MHz	45	75	—	dB
447... 824 MHz	45	61	—	dB
824... 849 MHz	50	60	—	dB
@ $f_{carrier}$ 826.4... 846.6 MHz	55	61	—	dB
849... 854 MHz	10	56	—	dB
854... 871.5 MHz	0.9	1.3	—	dB
909... 914 MHz	10	20	—	dB
914... 940 MHz	20	27	—	dB
940... 1000 MHz	40	49	—	dB
1000... 1693 MHz	40	53	—	dB
1693... 1850 MHz	45	54	—	dB
1850... 1920 MHz	40	54	—	dB
1920... 5000 MHz	40	46	—	dB

Data sheet

Characteristics ANT – RX	min.	typ. @+25 °C	max.	
5000... 6000 MHz α_{min}	30	41	—	dB
IMD product levels²⁾				
IMD2				
Blocker 1 45 MHz	—	-125	-109	dBm
Blocker 3 1718 MHz	—	-106	-96	dBm
IMD3				
Blocker 2 791.5 MHz	—	-106	-96	dBm
Blocker 4 2554.5 MHz	—	-115	-105	dBm

- ¹⁾ Error Vector Magnitude (EVM) based on definition given in 3GPP TS 25.141.
- ²⁾ Power levels: 21.5 dBm Tx signal, -15dBm blocker at antenna port.
- ³⁾ Attenuation of WCDMA signal ("power transfer function"). Please refer to definition of Power Transfer Function (PTF) of WCDMA signal (p. 22).
- ⁴⁾ A combination of 10` phase balance and 1 dB amplitude balance corresponds to 19.6 dB CMRR.

SAW Components	B8576
SAW Duplexer	836.5 / 881.5 MHz

Data sheet

6.3 TX – RX

Temperature range for specification	T	= -30 °C to +90 °C
TX terminating impedance	Z_{TX}	= 50 Ω
ANT terminating impedance	Z_{ANT}	= 50 Ω with par. 8.2 nH
RX terminating impedance	Z_{RX}	= 100 Ω (balanced)

Characteristics TX – RX				min.	typ. @+25 °C	max.	
Differential Mode Isolation							
		α_{min}					
	824... 849	MHz		54	63	—	dB
$@f_{carrier}$	826.4... 846.6	MHz	$\alpha_{WCDMA,min}^{1)}$	57	63	—	dB
	869... 894	MHz		50	55	—	dB
$@f_{carrier}$	871.4... 891.6	MHz	$\alpha_{WCDMA,min}^{1)}$	52	56	—	dB
	1574... 1577	MHz		40	64	—	dB
	1638... 1708	MHz		40	62	—	dB
	2462... 2557	MHz		40	56	—	dB
Common Mode Isolation							
	824... 849	MHz		42	47	—	dB
$@f_{carrier}$	826.4... 846.6	MHz	$\alpha_{WCDMA,min}^{1)}$	42	48	—	dB

¹⁾ Attenuation of WCDMA signal ("power transfer function"). Please refer to definition of Power Transfer Function (PTF) of WCDMA signal (p. 22).

SAW Components	B8576
SAW Duplexer	836.5 / 881.5 MHz

Data sheet

7 Maximum ratings

Storage temperature	$T_{STG} = -40\text{ °C to }+85\text{ °C}$	
DC voltage	$V_{DC} = 5.0\text{ V (max.)}^{1)}$	
ESD voltage	$V_{ESD}^{2)} = 100\text{ V (max.)}$	Machine model.
Input power	P_{IN}	
@ TX port: elsewhere MHz (min.)	10 dBm	Continuous wave for 5000 h @ 50 °C.
@ TX port: 824 ... 849 MHz	29 dBm	Continuous wave for 5000 h @ 50 °C.

¹⁾ 168h Damp Heat Steady State acc. IEC 60068-2-67 Cy.

²⁾ According to JESD22-A115B (MM – Machine Model), 10 negative & 10 positive pulses.

Data sheet

8 Transmission coefficients

8.1 TX – ANT

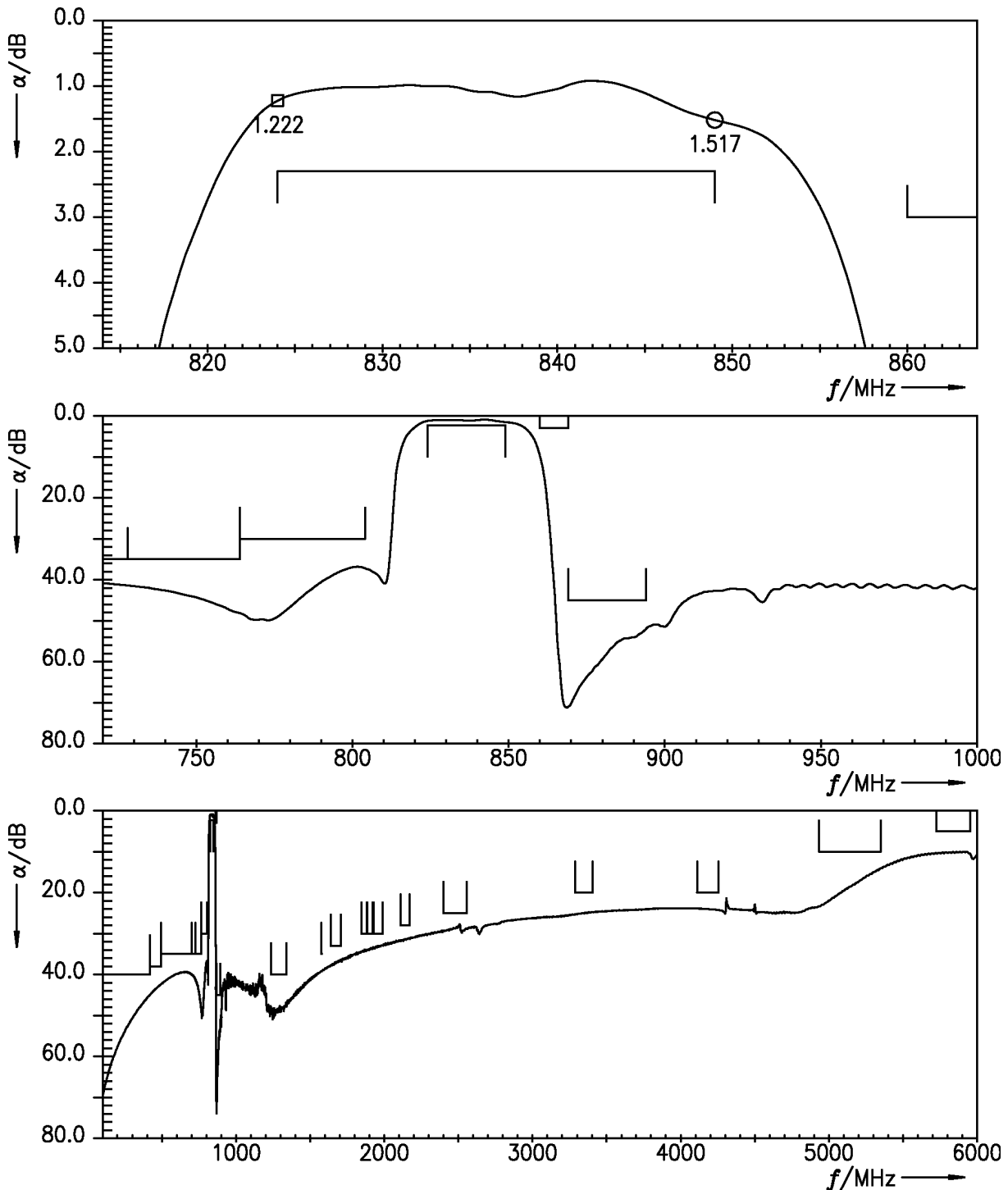

Figure 4: Attenuation TX – ANT.

Data sheet

8.2 ANT – RX

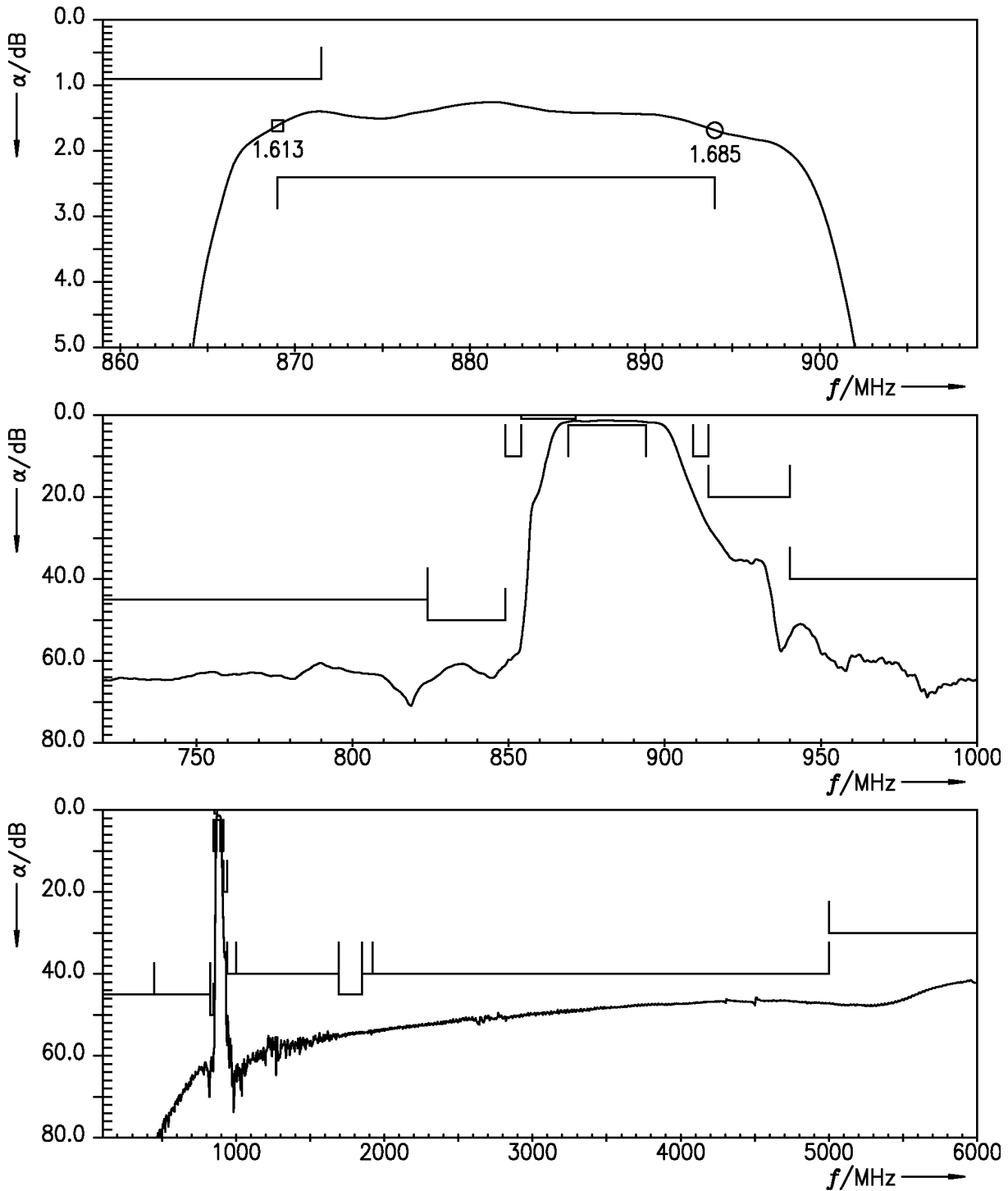

Figure 5: Balanced attenuation ANT – RX.

Data sheet

8.3 TX – RX

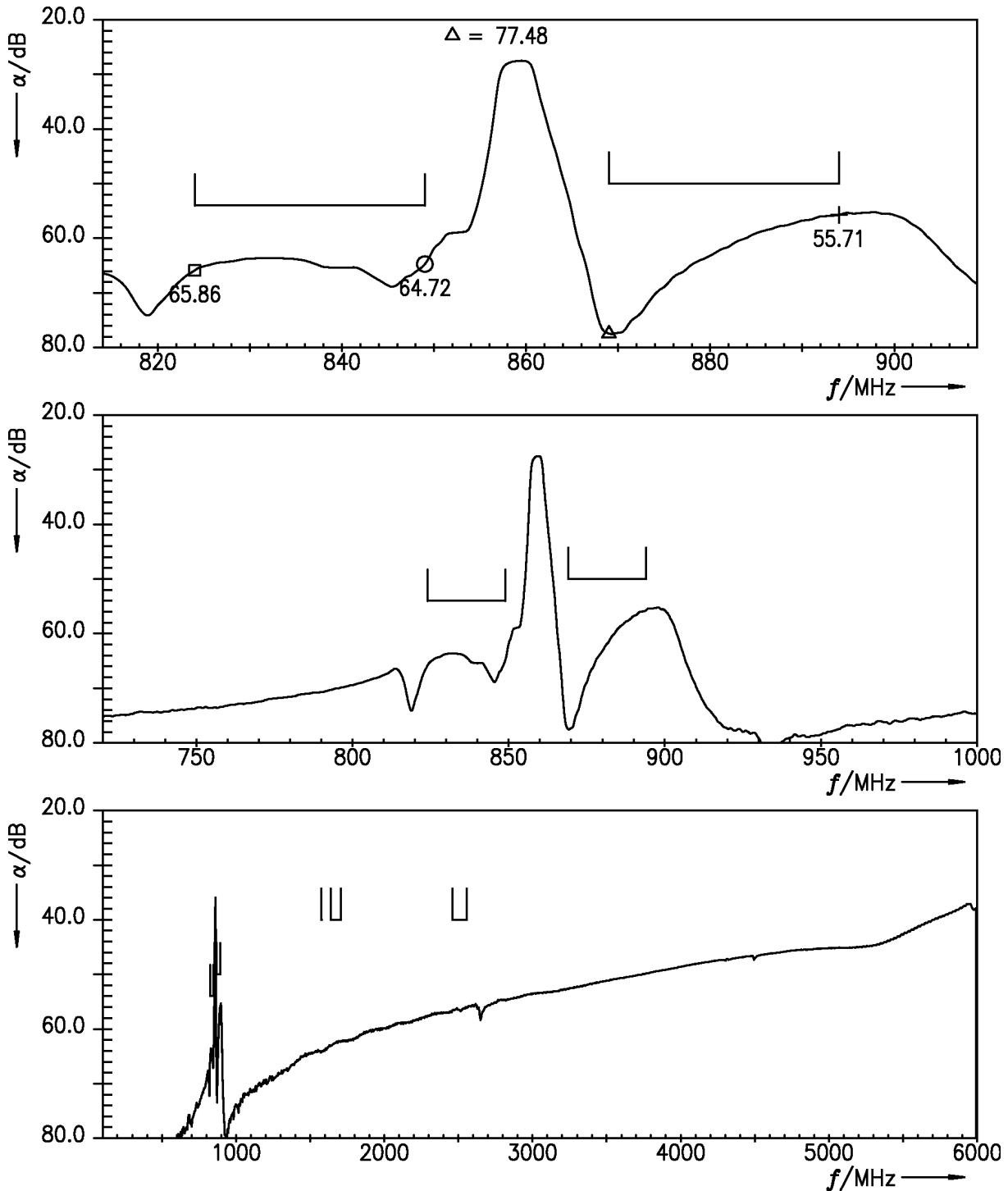

Figure 6: Balanced isolation TX – RX.

Data sheet

9 Reflection coefficients

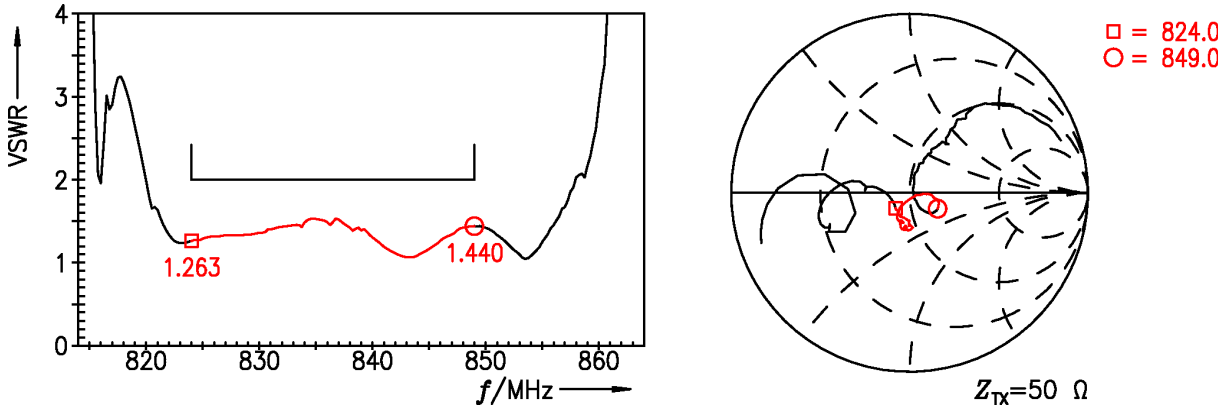

Figure 7: Reflection coefficient at TX port.

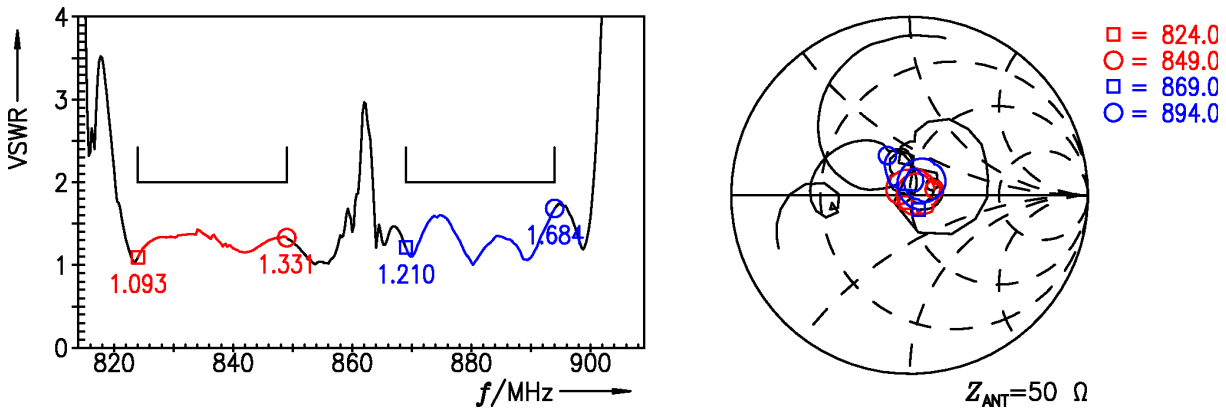

Figure 8: Reflection coefficient at ANT port (TX and RX frequencies).

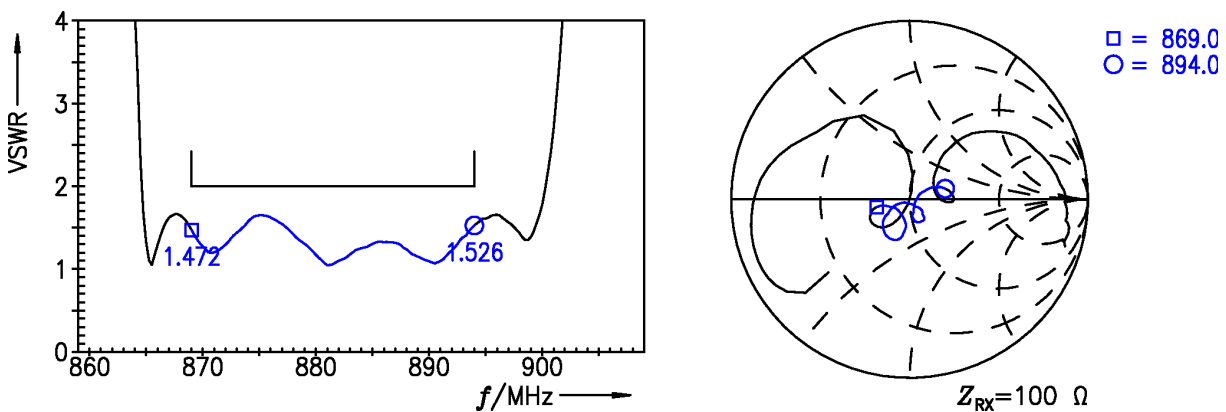

Figure 9: Reflection coefficient at RX port.

Data sheet

10 Packing material

10.1 Tape

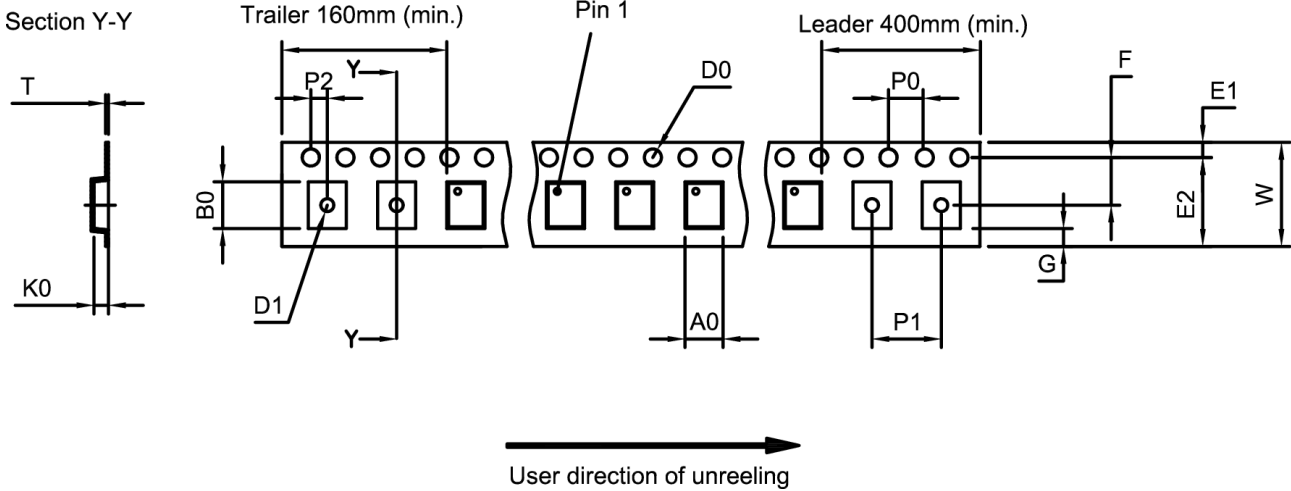

Figure 10: Drawing of tape (first-angle projection) with tape dimensions according to Table 1.

A ₀	1.62±0.05 mm
B ₀	2.04±0.05 mm
D ₀	1.5±0.05 mm
D ₁	0.8±0.05 mm
E ₁	1.75±0.1 mm

E ₂	6.25 mm (min.)
F	3.5±0.05 mm
G	0.75 mm (min.)
K ₀	0.62±0.05 mm
P ₀	4.0±0.1 mm

P ₁	4.0±0.1 mm
P ₂	2.0±0.05 mm
T	0.25±0.02 mm
W	8.0±0.1 mm

Table 1: Tape dimensions.

10.2 Reel with diameter of 180 mm

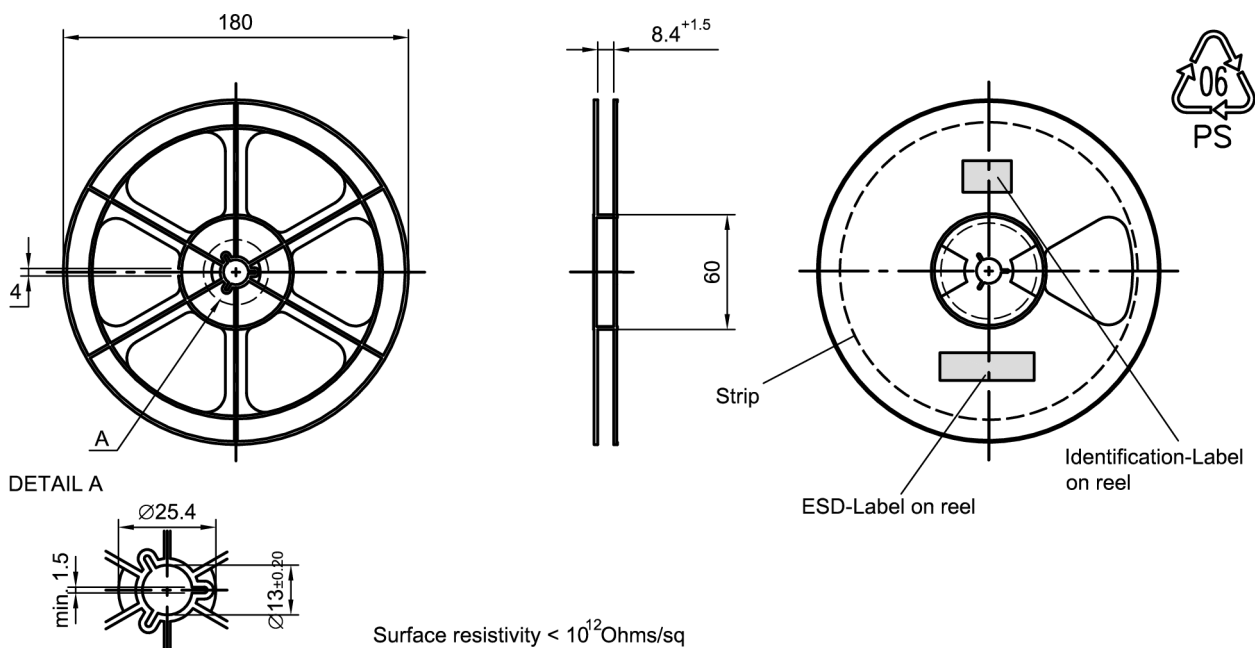

Figure 11: Drawing of reel (first-angle projection) with diameter of 180 mm.

Data sheet

Dimensions [mm]

X = 220+5

Y = 235+5

Sealing area 10 ±3

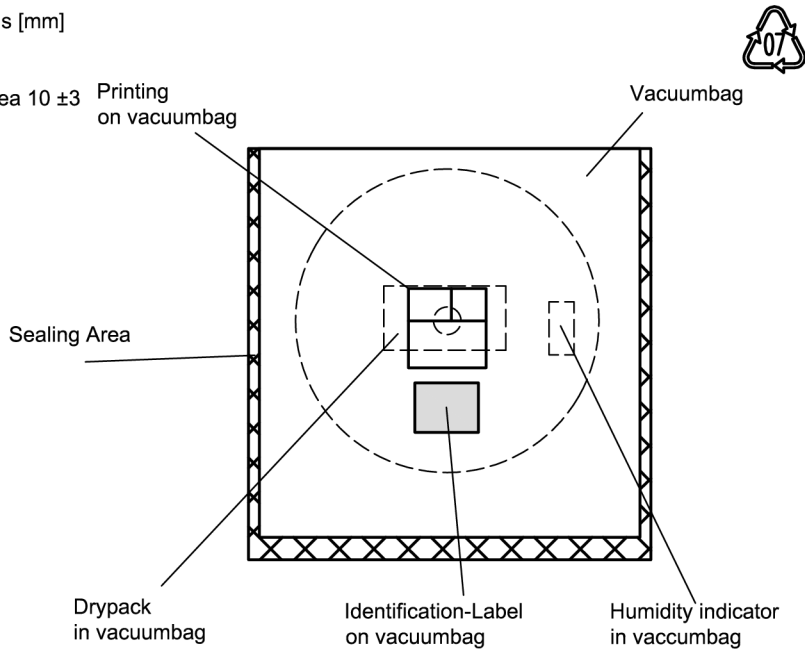

Figure 12: Drawing of moisture barrier bag (MBB) for reel with diameter of 180 mm.

Dimensions [mm]

L = 188

B = 188

H = 30

Tolerance ±5

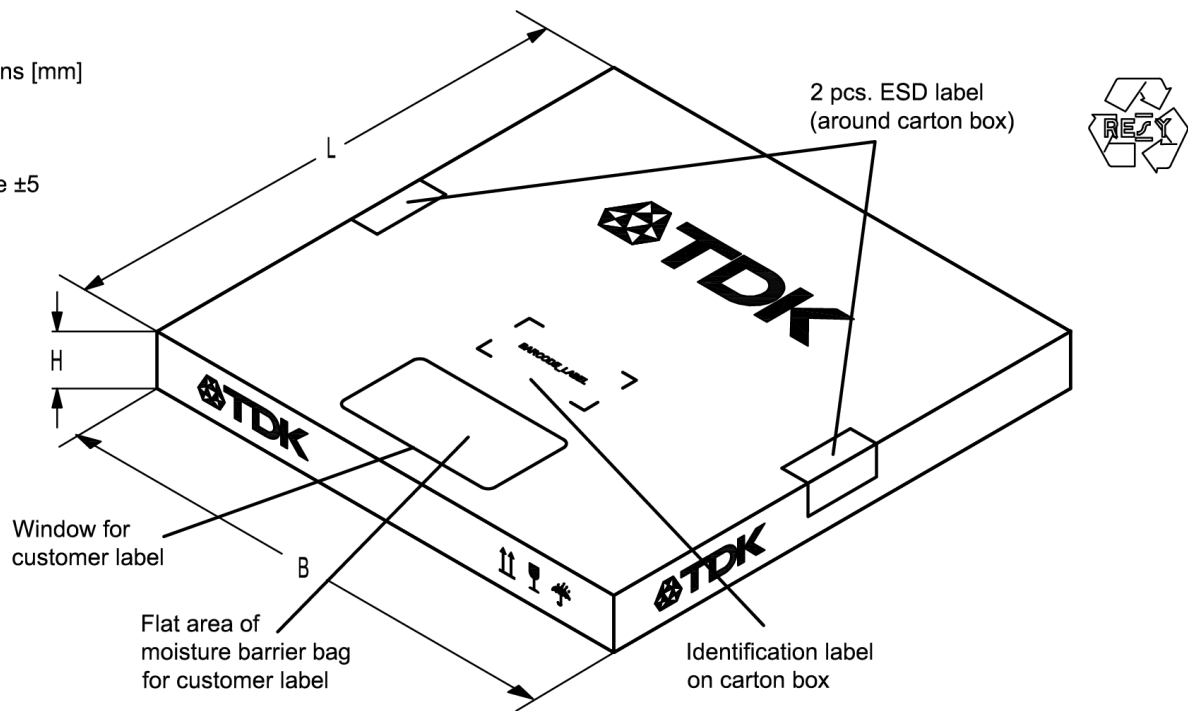

Figure 13: Drawing of folding box for reel with diameter of 180 mm.

Data sheet

10.3 Reel with diameter of 330 mm

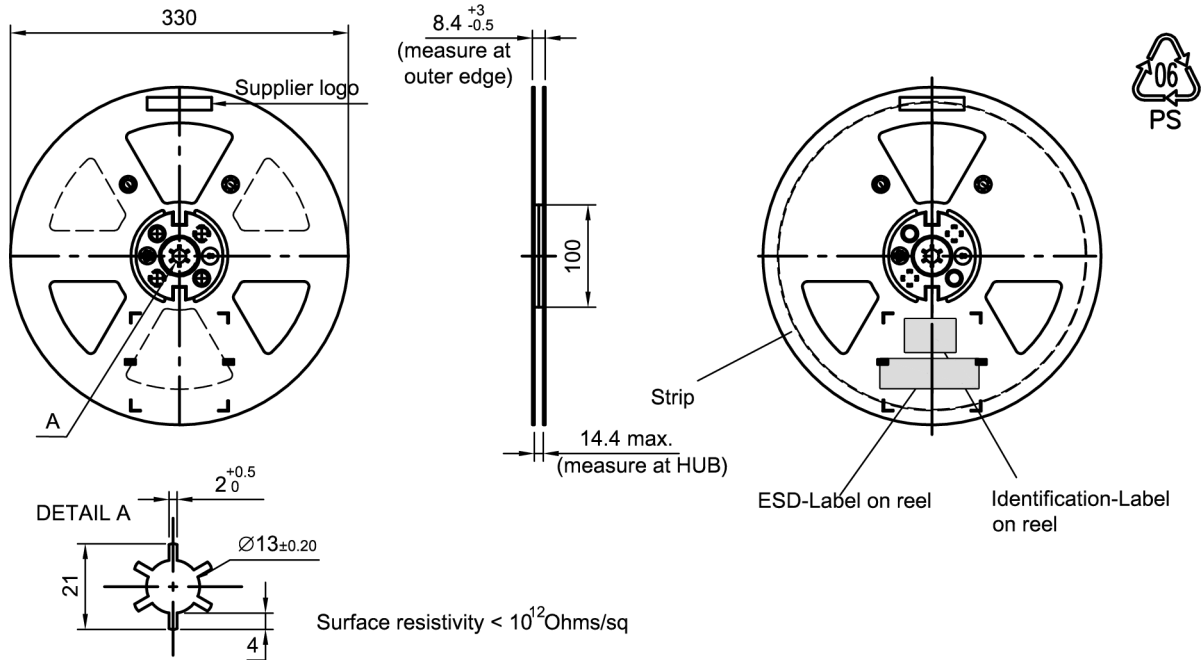

Figure 14: Drawing of reel (first-angle projection) with diameter of 330 mm.

Dimensions [mm]

X = 400+5

Y = 418+5

Sealing area 10 ± 3

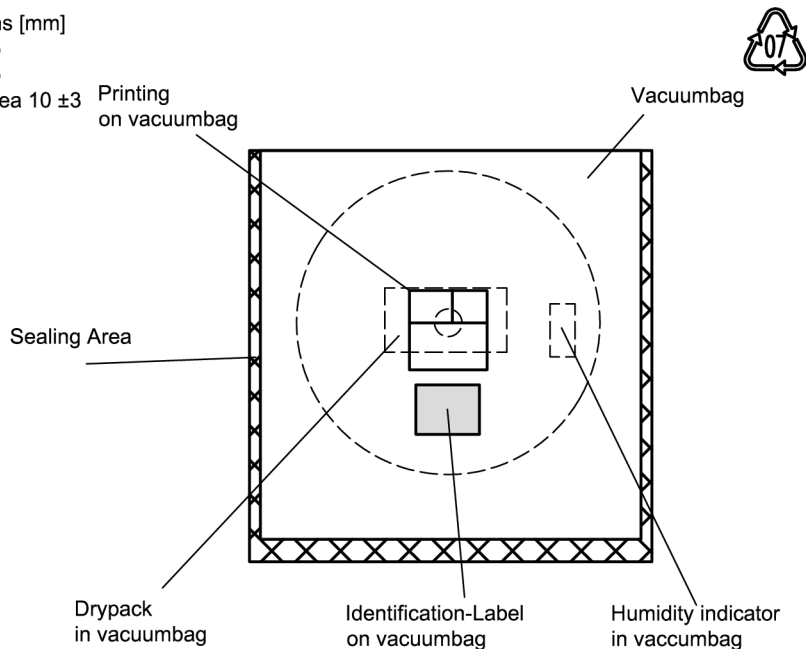
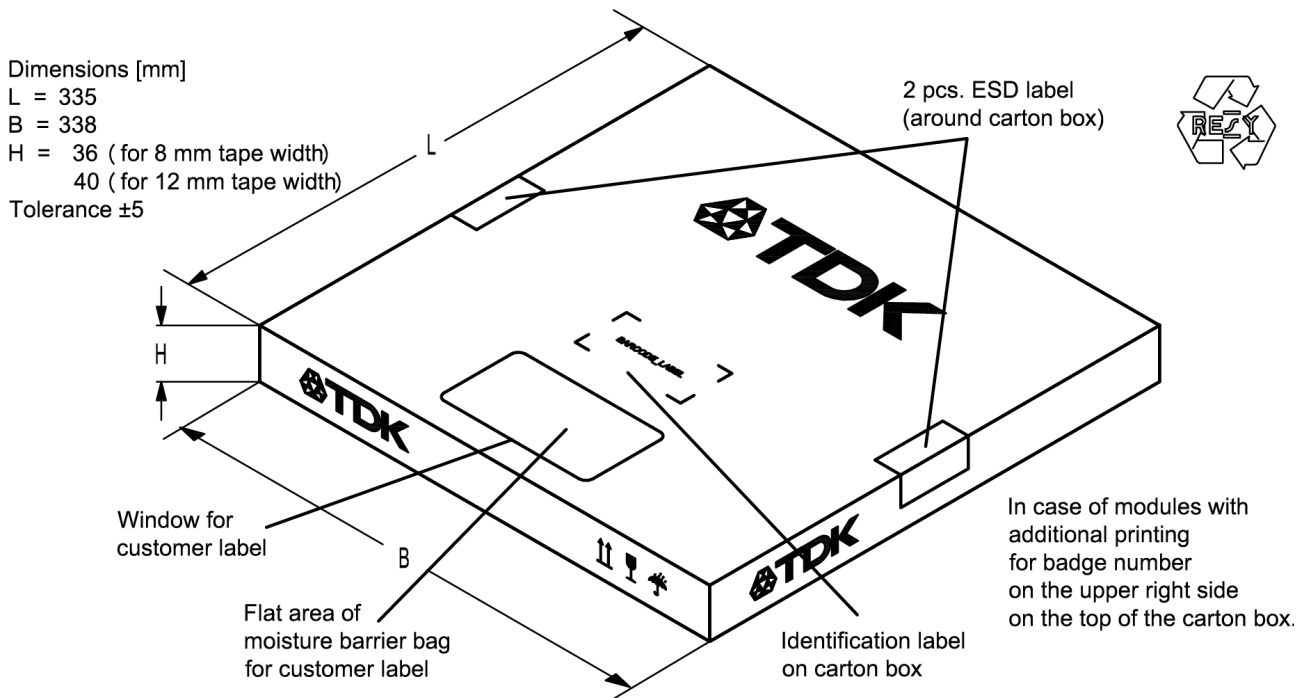

Figure 15: Drawing of moisture barrier bag (MBB) for reel with diameter of 330 mm.

Data sheet

Figure 16: Drawing of folding box for reel with diameter of 330 mm.

11 Marking

Products are marked with product type number and lot number encoded according to Table 2:

■ Type number:

The 4 digit type number of the ordering code, is encoded by a special BASE32 code into a 3 digit marking.

 e.g., B3xxxxB**1234**xxxx,

Example of decoding type number marking on device

in decimal code.

$$\begin{array}{rcl} \mathbf{16J} & \Rightarrow & \mathbf{1234} \\ \mathbf{1 \times 32^2 + 6 \times 32^1 + 18 (=J) \times 32^0} & = & \mathbf{1234} \end{array}$$

The BASE32 code for product type B8576 is 8C0.

■ Lot number:

The last 5 digits of the lot number, are encoded based on a special BASE47 code into a 3 digit marking.

 e.g., **12345**,

Example of decoding lot number marking on device

in decimal code.

$$\begin{array}{rcl} \mathbf{5UY} & \Rightarrow & \mathbf{12345} \\ \mathbf{5 \times 47^2 + 27 (=U) \times 47^1 + 31 (=Y) \times 47^0} & = & \mathbf{12345} \end{array}$$

Data sheet

Adopted BASE32 code for type number			
Decimal value	Base32 code	Decimal value	Base32 code
0	0	16	G
1	1	17	H
2	2	18	J
3	3	19	K
4	4	20	M
5	5	21	N
6	6	22	P
7	7	23	Q
8	8	24	R
9	9	25	S
10	A	26	T
11	B	27	V
12	C	28	W
13	D	29	X
14	E	30	Y
15	F	31	Z

Adopted BASE47 code for lot number			
Decimal value	Base47 code	Decimal value	Base47 code
0	0	24	R
1	1	25	S
2	2	26	T
3	3	27	U
4	4	28	V
5	5	29	W
6	6	30	X
7	7	31	Y
8	8	32	Z
9	9	33	b
10	A	34	d
11	B	35	f
12	C	36	h
13	D	37	n
14	E	38	r
15	F	39	t
16	G	40	v
17	H	41	\
18	J	42	?
19	K	43	{
20	L	44	}
21	M	45	<
22	N	46	>
23	P		

Table 2: Lists for encoding and decoding of marking.

Data sheet

12 Soldering profile

The recommended soldering process is in accordance with IEC 60068-2-58 – 3rd edit and IPC/JEDEC J-STD-020B.

ramp rate	≤ 3 K/s
preheat	125 °C to 220 °C, 150 s to 210 s, 0.4 K/s to 1.0 K/s
$T > 220\text{ °C}$	30 s to 70 s
$T > 230\text{ °C}$	min. 10 s
$T > 245\text{ °C}$	max. 20 s
$T \geq 255\text{ °C}$	–
peak temperature T_{peak}	250 °C +0/-5 °C
wetting temperature T_{min}	230 °C +5/-0 °C for 10 s ± 1 s
cooling rate	≤ 3 K/s
soldering temperature T	measured at solder pads

Table 3: Characteristics of recommended soldering profile for lead-free solder (Sn95.5Ag3.8Cu0.7).

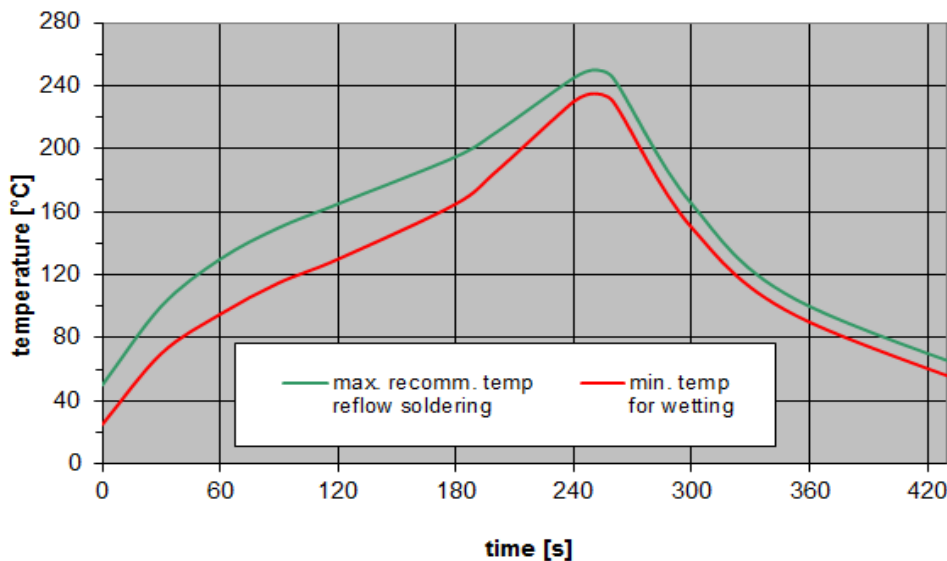

Figure 17: Recommended reflow profile for convection and infrared soldering – lead-free solder.

Data sheet

13 Annotations

13.1 Matching coils

See TDK inductor pdf-catalog <http://www.tdk.co.jp/tefe02/coil.htm#aname1> and Data Library for circuit simulation <http://www.tdk.co.jp/etvcl/index.htm>.

13.2 Power Transfer Function (PTF) of WCDMA signal

Attenuation of WCDMA signal, α_{WCDMA} , is defined by

$$\alpha_{\text{WCDMA}}(f_{\text{carrier}}) = 10 \log_{10} \left| \frac{1}{\text{PTF}(f_{\text{carrier}})} \right| \text{dB}$$

and

$$\text{PTF}(f_{\text{carrier}}) = \int_{-\infty}^{+\infty} |S_{21}(f) H_{\text{RRC}}(f - f_{\text{carrier}})|^2 df$$

with f_{carrier} according to 3GPP TS 25.101 (e.g., for the WCDMA B8 pass band, f_{carrier} ranges from 882.4 MHz to 912.6 MHz which correspond to the lowest and highest TX channels, respectively). $H_{\text{RRC}}(f)$ is the transfer function of the root-raised cosine transmit pulse shaping filter according to 3GPP TS 25.101 using the normalization

$$\int_{-\infty}^{+\infty} |H_{\text{RRC}}(f)|^2 df = 1 \quad .$$

13.3 RoHS compatibility

ROHS-compatible means that products are compatible with the requirements according to Art. 4 (substance restrictions) of Directive 2011/65/EU of the European Parliament and of the Council of June 8th, 2011, on the restriction of the use of certain hazardous substances in electrical and electronic equipment ("Directive") with due regard to the application of exemptions as per Annex III of the Directive in certain cases.

13.4 Scattering parameters (S-parameters)

The pin/port assignment is available in the headers of the S-parameter files. Please contact your local EPCOS sales office.

13.5 Ordering code and packing units

Ordering code	Packing units
B39881B8576P810	15000 pcs
B39881B8576P810S 5	5000 pcs

Table 4: Ordering codes and packing units.

14 Cautions and warnings

14.1 Moldability

Before using in overmolding environment, please contact your local EPCOS sales office.

Data sheet

14.2 Simplified drawings

Landing area

The printed circuit board (PCB) land pattern (landing area) shown is based on EPCOS internal development and empirical data and illustrated for example purposes, only. As customers' SMD assembly processes may have a plenty of variants and influence factors which are not under control or knowledge of EPCOS, additional careful process development on customer side is necessary and strongly recommended in order to achieve best soldering results tailored to the particular customer needs.

Dimensions

Unless otherwise specified all dimensions are understood using unit millimeter (mm).

Projection method

Unless otherwise specified first-angle projection is applied.

Contact and Important notes

For further information please contact your local EPCOS sales office or visit our web page at www.epcos.com.

Published by EPCOS AG
Systems, Acoustics, Waves Business Group
P.O. Box 80 17 09, 81617 Munich, GERMANY

© EPCOS AG 2015. This brochure replaces the previous edition.

For questions on technology, prices and delivery please contact the sales offices of EPCOS AG or the international representatives.

Due to technical requirements components may contain dangerous substances. For information on the type in question please also contact one of our sales offices.

Important notes

The following applies to all products named in this publication:

1. Some parts of this publication contain **statements about the suitability of our products for certain areas of application**. These statements are based on our knowledge of typical requirements that are often placed on our products in the areas of application concerned. We nevertheless expressly point out **that such statements cannot be regarded as binding statements about the suitability of our products for a particular customer application**. As a rule, EPCOS is either unfamiliar with individual customer applications or less familiar with them than the customers themselves. For these reasons, it is always ultimately incumbent on the customer to check and decide whether an EPCOS product with the properties described in the product specification is suitable for use in a particular customer application.
2. We also point out that **in individual cases, a malfunction of electronic components or failure before the end of their usual service life cannot be completely ruled out in the current state of the art, even if they are operated as specified**. In customer applications requiring a very high level of operational safety and especially in customer applications in which the malfunction or failure of an electronic component could endanger human life or health (e.g. in accident prevention or life-saving systems), it must therefore be ensured by means of suitable design of the customer application or other action taken by the customer (e.g. installation of protective circuitry or redundancy) that no injury or damage is sustained by third parties in the event of malfunction or failure of an electronic component.
3. **The warnings, cautions and product-specific notes must be observed.**
4. In order to satisfy certain technical requirements, **some of the products described in this publication may contain substances subject to restrictions in certain jurisdictions (e.g. because they are classed as hazardous)**. Useful information on this will be found in our Material Data Sheets on the Internet (www.epcos.com/material). Should you have any more detailed questions, please contact our sales offices.
5. We constantly strive to improve our products. Consequently, **the products described in this publication may change from time to time**. The same is true of the corresponding product specifications. Please check therefore to what extent product descriptions and specifications contained in this publication are still applicable before or when you place an order. We also **reserve the right to discontinue production and delivery of products**. Consequently, we cannot guarantee that all products named in this publication will always be available.
The aforementioned does not apply in the case of individual agreements deviating from the foregoing for customer-specific products.
6. Unless otherwise agreed in individual contracts, **all orders are subject to the current version of the “General Terms of Delivery for Products and Services in the Electrical Industry” published by the German Electrical and Electronics Industry Association (ZVEI)**.
7. The trade names EPCOS, Alu-X, CeraDiode, CeraLink, CeraPad, CeraPlas, CSMP, CSSP, CTVS, DeltaCap, DigiSiMic, DSSP, ExoCore, FilterCap, FormFit, LeaXield, MiniBlue, MiniCell, MKD, MKK, MotorCap, PCC, PhaseCap, PhaseCube, PhaseMod, PhiCap, PQSine, SIFERRIT, SIFI, SIKOREL, SilverCap, SIMDAD, SiMic, SIMID, SineFormer, SIOV, SIP5D, SIP5K, TFAP, ThermoFuse, WindCap are **trademarks registered or pending** in Europe and in other countries. Further information will be found on the Internet at www.epcos.com/trademarks.

单击下面可查看定价，库存，交付和生命周期等信息

[>>RF360 / Qualcomm](#)