

1 Scope:

- 1.1 This specification is applicable to lead free and halogen free for LRH series low-inductance metal alloy low-resistance resistor.
- 1.2 The product is belong to the universal series.

2 Explanation Of Part Numbers:

| Type | Size (inch) | Type of Terminal | Rated Power | Resistance (4~6 Digits) | Tolerance | Packaging |
|--|--|------------------------------------|--|---|--|--|
| Low-Inductance Metal Alloy Low Resistance Resistor | 0402 0603 0805 1206 2010 2512 2725 4527 | 2 : 2 terminals T : wrap around | H=0.20W F=0.33W C=0.5W A=1.5W 1=1W 2=2W 3=3W 4=4W 5=5W | EX: R003 = 3mΩ R0015 = 1.50mΩ R0005 = 0.50mΩ R00075= 0.75mΩ R100 = 100mΩ | D=±0.5% F=±1.0% G=±2.0% J=±5.0% | A=500pcs 1=1,000pcs 2=2,000pcs 4=4,000pcs 5=5,000pcs 10=10,000pcs |

3 Product Specifications:

| Type | Type of Terminal | Max. Rating Power | (I _r) Rating Current | (I _o) Overload Current | T.C.R. (ppm/°C) | Inductance | Resistance Range (mΩ) | | Operating Temperature Range | | |
|------|------------------|-------------------|----------------------------------|------------------------------------|-----------------|-------------|-----------------------|-------------------------------|-----------------------------|------------|------------|
| | | | | | | | D (±0.5%) | F (±1%) G (±2%) J (±5%) | | | |
| 0402 | 2 | 1/5W | $I_r = \sqrt{P/R}$ | $I_o = \sqrt{NP/R}$ | | < 5nH | -- | 1.5 ~ 2 | -55~+150°C | | |
| | | | | | | | -- | 3 | | | |
| | | | | | | | -- | 4 ~ 5 | | | |
| 0603 | 2 | 1/3W | | | | | ≤ ±50 | ≤ ±450 | | -- | 1 ≤ R < 4 |
| | | | | | | | ≤ ±50 | ≤ ±50 | | -- | 4 ≤ R ≤ 24 |
| | | | | | | | ≤ ±100 | ≤ ±100 | | -- | 1 ≤ R < 3 |
| 0805 | 2 | 1/2W | | | | | ≤ ±75 | ≤ ±75 | | -- | 3 ≤ R < 5 |
| | | | | | | | ≤ ±50 | ≤ ±50 | | 5 ≤ R ≤ 19 | 5 ≤ R ≤ 19 |
| | | 3/4W | | | | | ≤ ±100 | ≤ ±100 | | -- | 1 ≤ R < 3 |
| | | | | | | | ≤ ±75 | ≤ ±75 | | -- | 3 ≤ R < 5 |
| 1206 | 2 | 1/2W | | | | | ≤ ±50 | ≤ ±400 | | -- | 1 ≤ R < 2 |
| | | | | | | | ≤ ±100 | ≤ ±75 | | -- | 2 ≤ R < 4 |
| | | 1W | | | | | ≤ ±50 | ≤ ±50 | | 4 ≤ R ≤ 21 | 4 ≤ R ≤ 21 |
| | | | | | | | ≤ ±400 | ≤ ±75 | | -- | 1 ≤ R < 2 |
| 0805 | T | 1/2W | | | | | ≤ ±75 | ≤ ±75 | | -- | 2 ≤ R < 4 |
| | | | ≤ ±50 | ≤ ±50 | 4 ≤ R ≤ 10 | 4 ≤ R ≤ 10 | | | | | |
| | | 3/4W | ≤ ±100 | ≤ ±100 | -- | 1.5 ≤ R < 3 | | | | | |
| | | | ≤ ±75 | ≤ ±75 | -- | 3 ≤ R < 5 | | | | | |
| 1206 | T | 1/2W | ≤ ±50 | ≤ ±400 | -- | 1 ≤ R < 2 | | | | | |
| | | | ≤ ±100 | ≤ ±75 | -- | 2 ≤ R < 4 | | | | | |
| | | 1W | ≤ ±50 | ≤ ±50 | 4 ≤ R ≤ 10 | 4 ≤ R ≤ 10 | | | | | |
| | | | ≤ ±400 | ≤ ±75 | -- | 1 ≤ R < 2 | | | | | |
| 2010 | 2 | 1W | ≤ ±50 | ≤ ±50 | -- | 5~90 | | | | | |
| | | 1.5W | ≤ ±50 | ≤ ±50 | -- | 5~60 | | | | | |
| | | 2W | ≤ ±50 | ≤ ±50 | -- | 5~10 | | | | | |
| 2512 | 2 | 1W | ≤ ±50 | | 3~50 | 3~100 | | | | | |
| | | 1.5W | | | 3~50 | 3~100 | | | | | |
| | | 2W | | | 3~50 | 3~70 | | | | | |
| 2725 | 2 | 3W | ≤ ±100 | | 3~10 | 3~10 | | | | | |
| | | 4W | | | -- | 0.2 | | | | | |
| | | 5W | | | -- | 0.25~3 | | | | | |
| | | | ≤ ±100 | ≤ ±100 | -- | 0.2 | | | | | |
| | | | ≤ ±50 | ≤ ±50 | -- | 0.25~3 | | | | | |
| | | | ≤ ±100 | ≤ ±100 | -- | 0.2 | | | | | |
| | | | ≤ ±50 | ≤ ±50 | -- | 0.25~3 | | | | | |
| | | | ≤ ±100 | ≤ ±100 | -- | 0.2 | | | | | |
| | | | ≤ ±50 | ≤ ±50 | -- | 0.25~3 | | | | | |

| Type | Type of Terminal | Max. Rating Power | (Ir) Rating Current | (Io) Overload Current | T.C.R. (ppm/°C) | Inductance | Resistance Range (mΩ) | | | Operating Temperature Range |
|------|------------------|-------------------|---------------------|-----------------------|-----------------|------------|-----------------------|-------------------------------|------------|-----------------------------|
| | | | | | | | D (±0.5%) | F (±1%) G (±2%) J (±5%) | | |
| 4527 | 2 | 5W | $I_r = \sqrt{P/R}$ | $I_o = \sqrt{NP/R}$ | $\leq \pm 50$ | < 5nH | -- | 5~50 | -55~+170°C | |
| | | | | | | < 10nH | -- | 51~100 | | |

I_r = Rating Current(A)

I_o = Overload Current(A)

P= Rating Power(W)

R= Resistance(Ω)

N= LRH2010 / LRH2512 / LRH2725 / LRH4527 : 5

Others : 4

3.1 Power Derating Curve :

| Type | 0402/0603/0805/1206 | 2010/2512/2725/4527 |
|-----------------------------|---|---|
| Operating Temperature Range | -55°C ~ +150°C | -55°C ~ +170°C |
| Explain | For resistors operated in ambient temperatures above 70°C, power rating shall be derated in accordance with figure below. | For resistors operated in ambient temperatures above 70°C, power rating shall be derated in accordance with figure below. |
| Figure | | |

4 Physical Dimensions:

| | | |
|--------------------------------|---------------|---------------|
| <p>0402/0603</p> | <p>0805</p> | <p>1206</p> |
| <p>-Bottom-</p> <p>-Front-</p> | <p>0805-T</p> | <p>1206-T</p> |
| <p>2010</p> | <p>2512</p> | |
| <p>2725</p> | <p>4527</p> | |

| Type | Type of Terminal | Power Rating (Watts) | Resistance Range (mΩ) | Dimensions - in inches (millimeters) | | | | |
|------|------------------|----------------------|-----------------------|--------------------------------------|------------------------------|-------------------------------|------------------------------|------------------------------|
| | | | | L | W | H | T1 | T2 |
| 0402 | 2 | 1/5W | 1.5、2、3 4、5、10 | 0.039±0.004 (1.00±0.100) | 0.020±0.004 (0.50±0.100) | 0.014±0.004 (0.35±0.10) | 0.010±0.004 (0.25±0.100) | --- |
| 0603 | 2 | 1/3W | 1~24 | 0.063±0.008 (1.60±0.20) | 0.031±0.008 (0.80±0.20) | 0.014±0.004 (0.35±0.10) | 0.012±0.006 (0.30±0.15) | --- |
| 0805 | 2 | 1/2W | 1 | 0.08±0.008 (2.0320±0.20) | 0.05±0.008 (1.270±0.20) | 0.014±0.004 (0.50±0.10) | 0.023±0.006 (0.60±0.15) | --- |
| | | | 1.5、2、2.5 | 0.08±0.008 (2.0320±0.20) | 0.05±0.008 (1.270±0.20) | 0.014±0.004 (0.35±0.10) | 0.02±0.006 (0.50±0.15) | |
| | | | 3~19 | 0.08±0.008 (2.0320±0.20) | 0.05±0.008 (1.270±0.20) | 0.014±0.004 (0.35±0.10) | 0.014±0.008 (0.35±0.20) | |
| | | 3/4W | 1 | 0.08±0.008 (2.0320±0.20) | 0.05±0.008 (1.270±0.20) | 0.014±0.004 (0.50±0.10) | 0.023±0.006 (0.60±0.15) | |
| | | | 1.5、2、2.5 | 0.08±0.008 (2.0320±0.20) | 0.05±0.008 (1.270±0.20) | 0.014±0.004 (0.35±0.10) | 0.02±0.006 (0.50±0.15) | |
| | | | 3~10 | 0.08±0.008 (2.0320±0.20) | 0.05±0.008 (1.270±0.20) | 0.014±0.004 (0.35±0.10) | 0.014±0.008 (0.35±0.20) | |
| 1206 | 2 | 1/2W | 1 ≤ R < 3 | 0.126±0.008 (3.20±0.20) | 0.063±0.008 (1.60±0.20) | 0.016±0.008 (0.40±0.20) | 0.035±0.008 (0.90±0.20) | --- |
| | | | 3 ≤ R < 4 | | | | 0.028±0.008 (0.70±0.20) | |
| | | | 4 ≤ R ≤ 21 | | | | 0.014±0.008 (0.35±0.20) | |
| | | 1W | 1 ≤ R < 3 | 0.126±0.008 (3.20±0.20) | 0.063±0.008 (1.60±0.20) | 0.016±0.008 (0.40±0.20) | 0.035±0.008 (0.90±0.20) | |
| | | | 3 ≤ R < 4 | | | | 0.028±0.008 (0.70±0.20) | |
| | | | 4 ≤ R ≤ 10 | | | | 0.014±0.008 (0.35±0.20) | |
| 0805 | T | 1/2W | 1.5、2、2.5 | 0.08±0.008 (2.0320±0.20) | 0.05±0.008 (1.270±0.20) | 0.014±0.004 (0.35±0.10) | 0.02±0.006 (0.50±0.15) | 0.010±0.008 (0.25±0.20) |
| | | | 3~19 | | | | 0.014±0.008 (0.35±0.20) | |
| | | 3/4W | 1.5、2、2.5 | 0.08±0.008 (2.0320±0.20) | 0.05±0.008 (1.270±0.20) | 0.014±0.004 (0.35±0.10) | 0.02±0.006 (0.50±0.15) | |
| | | | 3~10 | | | | 0.014±0.008 (0.35±0.20) | |
| 1206 | T | 1/2W | 1 ≤ R < 3 | 0.126±0.008 (3.20±0.20) | 0.063±0.008 (1.60±0.20) | 0.016±0.008 (0.40±0.20) | 0.035±0.008 (0.90±0.20) | 0.010±0.008 (0.25±0.20) |
| | | | 3 ≤ R < 4 | | | | 0.028±0.008 (0.70±0.20) | |
| | | | 4 ≤ R ≤ 21 | | | | 0.014±0.008 (0.35±0.20) | |
| | | 1W | 1 ≤ R < 3 | 0.126±0.008 (3.20±0.20) | 0.063±0.008 (1.60±0.20) | 0.016±0.008 (0.40±0.20) | 0.035±0.008 (0.90±0.20) | |
| | | | 3 ≤ R < 4 | | | | 0.028±0.008 (0.70±0.20) | |
| | | | 4 ≤ R ≤ 10 | | | | 0.014±0.008 (0.35±0.20) | |
| 2010 | 2 | 1W | 5~90 | 0.200±0.010 (5.080±0.254) | 0.100±0.010 (2.540±0.254) | 0.031±0.010 (0.787±0.254) | 0.031±0.010 (0.787±0.254) | --- |
| | | 1.5W | 5~60 | | | | | |
| | | 2W | 5~10 | | | | | |
| 2512 | 2 | 1W | 3~70 | 0.246±0.010 (6.248±0.254) | 0.126±0.010 (3.202±0.254) | 0.0254±0.010 (0.645±0.254) | 0.044±0.010 (1.118±0.254) | 0.044±0.010 (1.118±0.254) |
| | | | 71~100 | | | | 0.034±0.010 (0.868±0.254) | 0.034±0.010 (0.868±0.254) |

| Type | Type of Terminal | Power Rating (Watts) | Resistance Range (mΩ) | Dimensions - in inches (millimeters) | | | | |
|------|------------------|----------------------|-----------------------|--------------------------------------|------------------------------|-------------------------------|------------------------------|------------------------------|
| | | | | L | W | H | T1 | T2 |
| 2512 | 2 | 1.5W | 3~70 | 0.246±0.010 (6.248±0.254) | 0.126±0.010 (3.202±0.254) | 0.0254±0.010 (0.645±0.254) | 0.044±0.010 (1.118±0.254) | 0.044±0.010 (1.118±0.254) |
| | | | 71~100 | | | | 0.034±0.010 (0.868±0.254) | 0.034±0.010 (0.868±0.254) |
| | | 2W | 3~70 | | | | 0.044±0.010 (1.118±0.254) | 0.044±0.010 (1.118±0.254) |
| | | 3W | 3~10 | | | | 0.044±0.010 (1.118±0.254) | 0.044±0.010 (1.118±0.254) |
| 2725 | 2 | 4W 5W | 0.2~0.3 | 0.268±0.010 (6.807±0.254) | 0.254±0.010 (6.452±0.254) | 0.039±0.010 (0.991±0.254) | 0.085±0.010 (2.159±0.254) | --- |
| | | | 0.35 | | | | 0.075±0.010 (1.900±0.254) | |
| | | | 0.40~0.45 | | | | 0.051±0.010 (1.300±0.254) | |
| | | | 0.5 | | | | 0.085±0.010 (2.159±0.254) | |
| | | | 0.6 | | | | 0.071±0.010 (1.803±0.254) | |
| | | | 0.75 | | | | 0.065±0.010 (1.651±0.254) | |
| | | | 1~1.5 | | | | 0.051±0.010 (1.300±0.254) | |
| | | | 2 | | | | 0.085±0.010 (2.159±0.254) | |
| | | | 3 | | | | 0.065±0.010 (1.651±0.254) | |
| 4527 | 2 | 5W | 5 | 0.450±0.010 (11.430±0.254) | 0.270±0.010 (6.850±0.254) | 0.059±0.010 (1.500±0.254) | 0.127±0.010 (3.215±0.254) | 0.038±0.010 (0.965±0.254) |
| | | | 5.1~100 | | | | 0.071±0.010 (1.815±0.254) | |

4.1 Material of Alloy

| Type | Material | Resistance |
|------|---------------------------------|-----------------------|
| 0402 | Manganese-Copper Alloy | 1.5mΩ / 2mΩ~5mΩ /10mΩ |
| 0603 | Manganese-Copper Alloy | 1mΩ- 24mΩ |
| 0805 | Manganese-Copper Alloy | 1mΩ- 19mΩ |
| 1206 | Manganese-Copper Alloy | 1mΩ- 21mΩ |
| 2010 | Manganese-Copper Alloy | 5mΩ- 10mΩ |
| | Nickel-Chromium- Aluminum Alloy | 11mΩ- 90mΩ |
| 2512 | Manganese-Copper Alloy | 3mΩ- 5mΩ |
| | Nickel-Chromium- Aluminum Alloy | 6mΩ- 100mΩ |
| 2725 | Manganese-Copper Alloy | 0.2mΩ~1.5mΩ |
| | Nickel-Chromium- Aluminum Alloy | 2mΩ~3mΩ |
| 4527 | Nickel-Chromium- Aluminum Alloy | 5mΩ~100mΩ |

5 Reliability Performance:

5.1 Electrical Performance :

| Test Item | Conditions of Test | Test Limits | | | | | | | | | | | | | | | | | | | | | | | | | | |
|---|--|---|-----------|------------------|------|-----|---------|------|------|---------|------|-----|---------|------|---------|---------|------|-------------|---------|------|-----------------|---------|------|---------|---------|------|-----|---------|
| Temperature Coefficient of Resistance (TCR) | <ul style="list-style-type: none"> TCR (ppm/°C) = $\frac{(R2-R1)}{R1 (T2-T1)} \times 10^6$ R1: resistance of room temperature R2: resistance of 150 °C T1: Room temperature T2: Temperature at 150 °C Refer to JIS C 5201-1 4.8 | Refer to Paragraph 3. general specifications | | | | | | | | | | | | | | | | | | | | | | | | | | |
| Short Time Overload | Applied Overload for 5 seconds and release the load for about 30 minutes, then measure its resistance variance rate. (Overload condition refer to below): | 0402、0805、1206、2010、2725 : $\leq \pm 0.5\%$ 2512、4527 : $\leq \pm 2\%$ | | | | | | | | | | | | | | | | | | | | | | | | | | |
| | <table border="1"> <thead> <tr> <th>Type</th> <th>Power (W)</th> <th># of rated power</th> </tr> </thead> <tbody> <tr> <td>0402</td> <td>0.2</td> <td>4 times</td> </tr> <tr> <td>0603</td> <td>0.33</td> <td>4 times</td> </tr> <tr> <td>0805</td> <td>0.5</td> <td>4 times</td> </tr> <tr> <td>1206</td> <td>0.5、1.0</td> <td>4 times</td> </tr> <tr> <td>2010</td> <td>1.0&1.5&2.0</td> <td>5 times</td> </tr> <tr> <td>2512</td> <td>1.0&1.5&2.0&3.0</td> <td>5 times</td> </tr> <tr> <td>2725</td> <td>4.0&5.0</td> <td>5 times</td> </tr> <tr> <td>4527</td> <td>5.0</td> <td>5 times</td> </tr> </tbody> </table> <p>Refer to JIS C 5201-1 4.13</p> | Type | Power (W) | # of rated power | 0402 | 0.2 | 4 times | 0603 | 0.33 | 4 times | 0805 | 0.5 | 4 times | 1206 | 0.5、1.0 | 4 times | 2010 | 1.0&1.5&2.0 | 5 times | 2512 | 1.0&1.5&2.0&3.0 | 5 times | 2725 | 4.0&5.0 | 5 times | 4527 | 5.0 | 5 times |
| Type | Power (W) | # of rated power | | | | | | | | | | | | | | | | | | | | | | | | | | |
| 0402 | 0.2 | 4 times | | | | | | | | | | | | | | | | | | | | | | | | | | |
| 0603 | 0.33 | 4 times | | | | | | | | | | | | | | | | | | | | | | | | | | |
| 0805 | 0.5 | 4 times | | | | | | | | | | | | | | | | | | | | | | | | | | |
| 1206 | 0.5、1.0 | 4 times | | | | | | | | | | | | | | | | | | | | | | | | | | |
| 2010 | 1.0&1.5&2.0 | 5 times | | | | | | | | | | | | | | | | | | | | | | | | | | |
| 2512 | 1.0&1.5&2.0&3.0 | 5 times | | | | | | | | | | | | | | | | | | | | | | | | | | |
| 2725 | 4.0&5.0 | 5 times | | | | | | | | | | | | | | | | | | | | | | | | | | |
| 4527 | 5.0 | 5 times | | | | | | | | | | | | | | | | | | | | | | | | | | |
| Insulation Resistance | Put the resistor in the fixture, add 100 VDC in +, - terminal for 60secs then measured the insulation resistance between electrodes and insulating enclosure or between electrodes and base material. Refer to JIS-C5201-1 4.6 | $\geq 10^8\Omega$ | | | | | | | | | | | | | | | | | | | | | | | | | | |
| Dielectric Withstanding Voltage | Applied 300VAC for 1 minute, and Limit surge current 50 mA (max.) Refer to JIS-C5201-1 4.7 | No short or burned on the appearance. | | | | | | | | | | | | | | | | | | | | | | | | | | |

5.2 Mechanical /Constructional Performance :

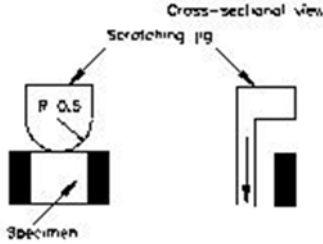
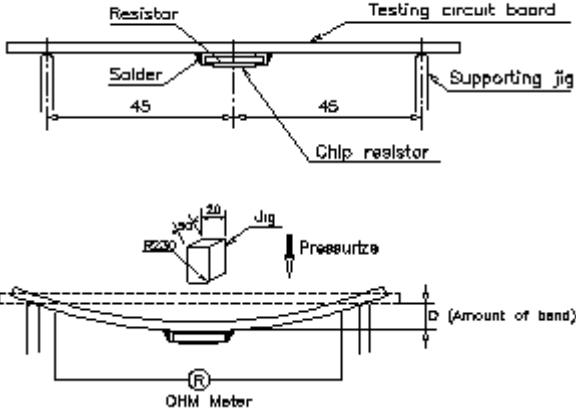
| Test Item | Conditions of Test | Test Limits |
|---|---|---|
| <p>Joint Strength of Solder</p> | <p>Test method: ◎Test item 1 (Adhesion): A static load using a R0.1 scratch tool shall be applied on the core of the component and in the direction of the arrow and held for 10 seconds and under 20N load measured its resistance variance rate.</p>  <p>Refer to JIS-C5201-1 4.32 ◎Test item 2 (Bending Strength): Solder tested resistor on to PC board add force in the middle down, and under load measured its resistance variance rate. 2512, 1206, 0805,D=3mm, 0603 D=5mm</p>  <p>Refer to JIS-C5201-1 4.33</p> | <p>Test item 1: (1).Variance rate on resistance : $\pm 1.0\%$ (2).No evidence of mechanical damage. No terminal peeling off.</p> <p>Test item 2: (1).Variance rate on resistance : $\pm 1.0\%$ (2).No evidence of mechanical damage. No terminal peeling off and core body cracked.</p> |
| <p>Resistance to Solder Heat</p> | <p>The tested resistor be immersed 25 mm/sec into molten solder of $260\pm 5^\circ\text{C}$ for 10 ± 1secs. Then the resistor is left in the room for 1 hour, and measured its resistance variance rate. Refer to JIS-C5201-1 4.18</p> | <p>$\leq \pm 0.5\%$ No evidence of mechanical damage</p> |
| <p>Solder ability</p> | <p>Add flux into tested resistors, immersion into solder bath in temperature $245\pm 5^\circ\text{C}$ for 3 ± 0.5secs. Refer to JIS-C5201-1 4.17</p> | <p>Solder coverage over 95%</p> |
| <p>Core Body Strength (1206 ((included)) above applies)</p> | <p>Applied R0.5 test probe at its central part then pushing 5N force on the sample for 10 sec. Refer to JIS-C5201-1 4.15</p> | <p>$\leq \pm 0.5\%$ No evidence of mechanical damage</p> |
| <p>Vibration</p> | <p>The resistor shall be mounted by its terminal leads to the supporting terminals on the solid table. The entire frequency range :from 10 Hz to 55 Hz and return to 10 Hz, shall be transferred in 1 min. Amplitude : 1.5mm This motion shall be applied for a period of 4 hours in each 3 mutually perpendicular directions (a total of 12hrs) Refer to JIS-C5201-1 4.22</p> | <p>$\leq \pm 0.5\%$ No evidence of mechanical damage</p> |

| Test Item | Conditions of Test | Test Limits |
|-----------------------|--|--|
| Resistance to solvent | The tested resistor be immersed into isopropyl alcohol of 20~25°C for 60secs, then the resistor is left in the room for 48 hrs. Refer to JIS-C5201-1 4.29 | ≤±0.5% No evidence of mechanical damage |

5.3 Environmental Performance :

| Test Item | Conditions of Test | Test Limits | | | | | | | | | | |
|---|---|--|--|-----------------------------|--------------|-----------------------------|--------------|--|---------|------------------------------|-------|------------|
| Low Temperature Exposure (Storage) | Put the tested resistor in chamber under temperature -55±2°C for 1,000 hours. Then leaving the tested resistor in room temperature for 60 minutes, and measure its resistance variance rate. Refer to JIS-C5201-1 4.23.4 | ≤±0.5% No evidence of mechanical damage | | | | | | | | | | |
| High Temperature Exposure (Storage) | Put tested resistor in chamber under temperature 2512:170±5°C (Others:150±5°C) for 1,000 hours. Then leaving the tested resistor in room temperature for 60 minutes, and measure its resistance variance rate. Refer to JIS-C5201-1 4.23.2 | ≤±1.0% No evidence of mechanical damage | | | | | | | | | | |
| Temperature Cycling (Rapid Temperature Change) | Put the tested resistor in the chamber under the temperature cycling which shown in the following table shall be repeated 300 times consecutively. Then leaving the tested resistor in the room temperature for 60 minutes, and measure its resistance variance rate. <table border="1" style="margin-left: 20px;"> <thead> <tr> <th colspan="2">Testing Condition</th> </tr> </thead> <tbody> <tr> <td>Lowest Temperature</td> <td>-55 +0/-10°C</td> </tr> <tr> <td>Highest Temperature</td> <td>150 +10/-0°C</td> </tr> </tbody> </table> Refer to JIS-C5201-1 4.19 | Testing Condition | | Lowest Temperature | -55 +0/-10°C | Highest Temperature | 150 +10/-0°C | 0402、0603、0805、1206 : ≤±1.0% 2010、2512、2725、4527 : ≤±0.5% No evidence of mechanical damage | | | | |
| | | Testing Condition | | | | | | | | | | |
| Lowest Temperature | -55 +0/-10°C | | | | | | | | | | | |
| Highest Temperature | 150 +10/-0°C | | | | | | | | | | | |
| Moisture Resistance (Climatic Sequence) | Put the tested resistor in chamber and subject to 10 cycles of damp heat and without power. Each one of which consists of the steps 1 to 7 (Figure 1). Then leaving the tested resistor in room temperature for 24 hr, and measure its resistance variance rate. Refer to MIL-STD 202 Method 106 | ≤±0.5% No evidence of mechanical damage | | | | | | | | | | |
| Bias Humidity | Put the tested resistor in chamber under 85±5°C and 85±5%RH with 10% bias and load the rated Power for 90 minutes on, 30 minutes off, total 1,000 hours. Then leaving the tested resistor in room temperature for 60 minutes, and measure its resistance variance rate. Refer to MIL-STD 202 Method 103 | 0402、0603 : ≤±1.0% 0805、1206、2010、2512、2725、4527 : ≤±0.5% No evidence of mechanical damage | | | | | | | | | | |
| | | Max. 50 μm | | | | | | | | | | |
| Whisker Test | ◎Test item (Thermal Shock test): <table border="1" style="margin-left: 20px;"> <thead> <tr> <th colspan="2">Testing Condition</th> </tr> </thead> <tbody> <tr> <td>Minimum storage temperature</td> <td>-55+0/-10°C</td> </tr> <tr> <td>Maximum storage temperature</td> <td>85+10/-0°C</td> </tr> <tr> <td>Temperature-retaining time</td> <td>10 min.</td> </tr> <tr> <td>Number of temperature cycles</td> <td>1,500</td> </tr> </tbody> </table> | Testing Condition | | Minimum storage temperature | -55+0/-10°C | Maximum storage temperature | 85+10/-0°C | Temperature-retaining time | 10 min. | Number of temperature cycles | 1,500 | Max. 50 μm |
| | Testing Condition | | | | | | | | | | | |
| Minimum storage temperature | -55+0/-10°C | | | | | | | | | | | |
| Maximum storage temperature | 85+10/-0°C | | | | | | | | | | | |
| Temperature-retaining time | 10 min. | | | | | | | | | | | |
| Number of temperature cycles | 1,500 | | | | | | | | | | | |
| ◎Inspection: Inspect for whisker formation on specimens that underwent the acceleration test specified in subclause 4.2, with a magnifier (stereo microscope) of about 40 or higher magnification. If judgment is hard in this method, use a scanning electron microscope (SEM) of about 1,000 or higher magnification. By JESD Standard NO.22A121 class 2. | | | | | | | | | | | | |

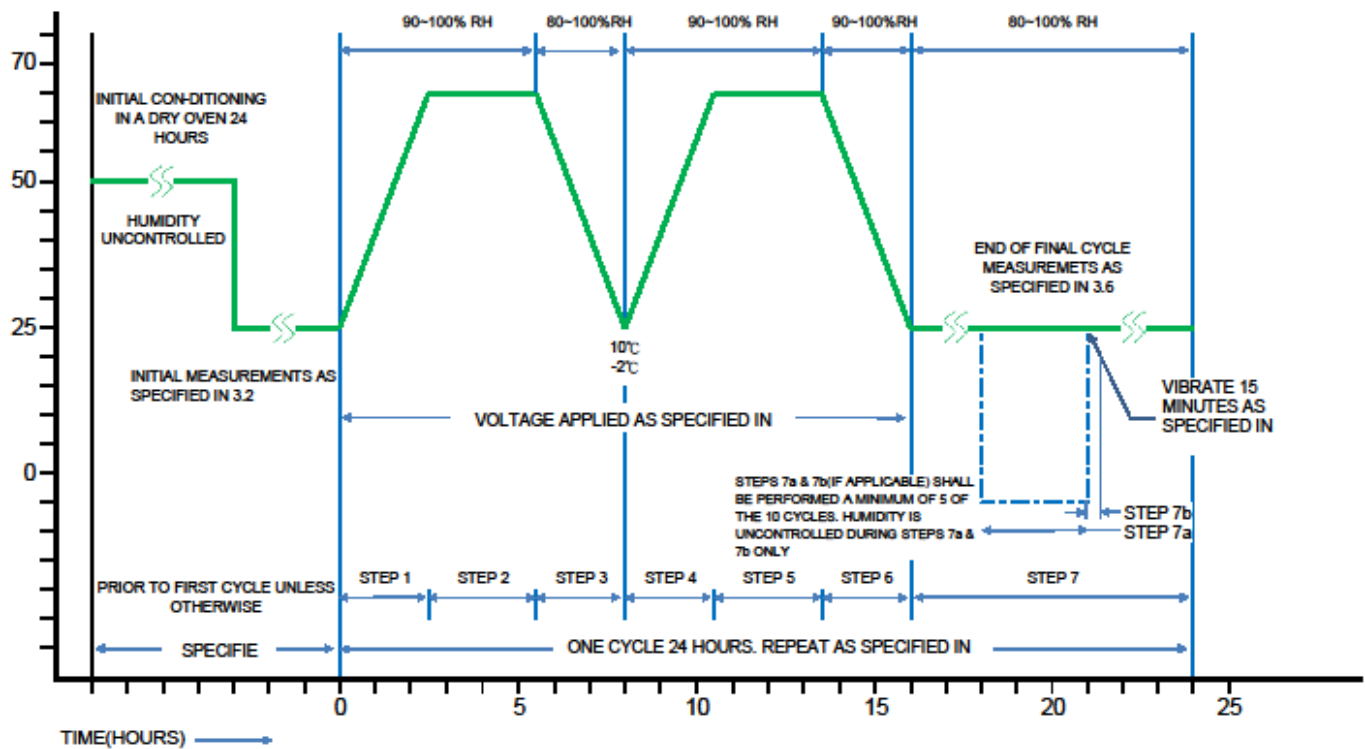

5.4 Operational Life Endurance :

| Test Item | Conditions of Test | Test Limits |
|-----------|--|--|
| Load Life | Put the tested resistor in chamber under temperature $70 \pm 2^\circ\text{C}$ and load the rated voltage for 90 minutes on 30 minutes off, total 1000 hours. Then leaving the tested resistor in room temperature for 60 minutes, and measure its resistance variance rate. Refer to JIS-C5201-1 4.25 | 0402、0603、0805、1206、2010、2725 : $\leq \pm 1.0\%$ 2512、4527 : $\leq \pm 2.0\%$ |
| | | No evidence of mechanical damage |



6 Marking Format:

6.1 Marking Styles by Laser(For LRH0805/LRH1206):

| LRH0805 | LRH1206 |
|---|--|
|  |  |

6.2 LRH1206、LRH2010、LRH2512、LRH4527 Series :

Product resistance is indicated by using two marking notation styles:

- a. “R” designates the decimal location in ohms, e.g.
 - For 1mΩ the product marking is R001;
 - For 25mΩ the product marking is R025;
 - For 100mΩ the product marking is R100.
- b. “m” designates the decimal location in milliohms, e.g.
 - For 0.25mΩ the product marking is 0m25;
 - For 0.5mΩ the product marking is 0m50;
 - For 5.5mΩ the product marking is 5m50;
 - For 25.5mΩ the product marking is 25m5.

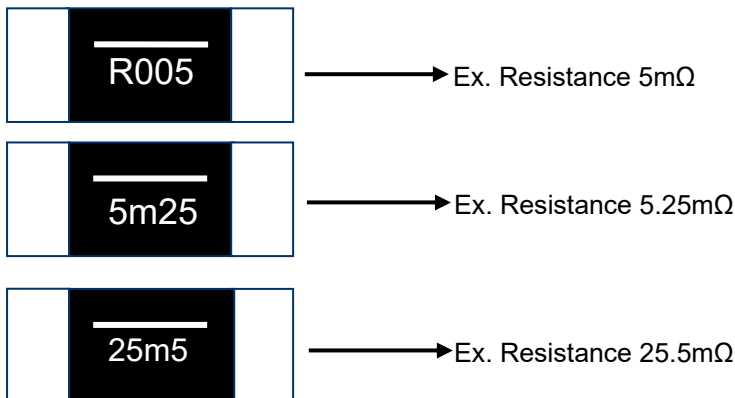

6.3 Marking Styles by Laser(For LRH1206) :

| Type \ Marking | R | m | 1 | 2 | 3 | 4 | 5 | 6 | 7 | 8 | 9 | 0 |
|----------------|------|---|---|---|---|---|---|---|---|---|---|---|
| | 1206 | | | | | | | | | | | |

6.4 Marking Style(For LRH2010/LRH2512) :

| Type \ Marking | R | m | 1 | 2 | 3 | 4 | 5 | 6 | 7 | 8 | 9 | 0 |
|----------------|--------------|---|---|---|---|---|---|---|---|---|---|---|
| | 2010 2512 | | | | | | | | | | | |

6.5 LRH0402 、LRH0603 No Marking.

7 Plating Thickness:

7.1 Ni : $\geq 2 \mu m$

7.2 Sn(Tin) : $\geq 3 \mu m$

7.3 Sn(Tin) : Matte Sn

8 Taping specifications:

8.1 Carrier Tape Dimensions :

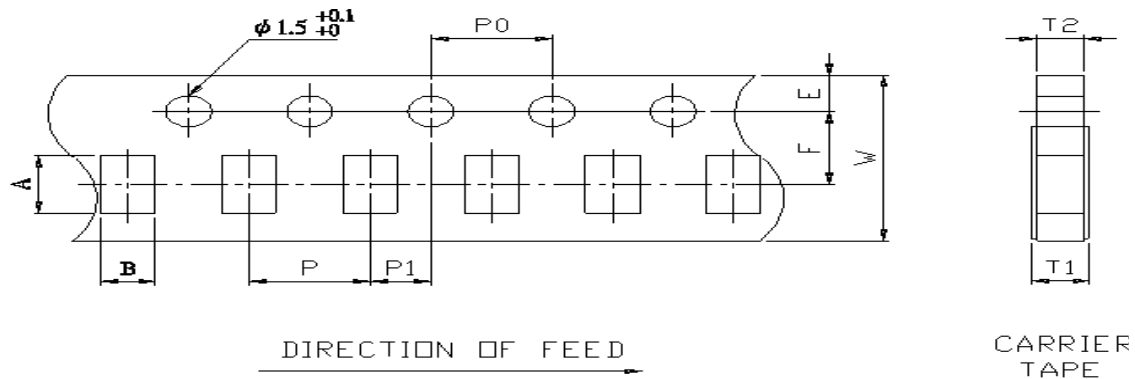

8.2 Embossed Tape Dimensions :

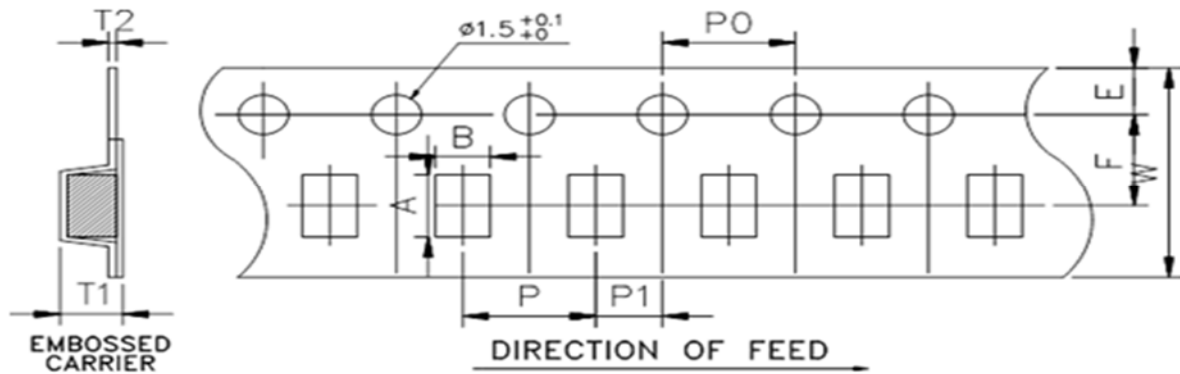

Unit : mm

| Item | DIM | A | B | W | E | F | T1 | T2 | P | P0 | 10*P0 | P1 |
|------|------------|------------|-----------|-----------|-----------|-----------|-------------|-----------|-----------|----------|-----------|----------|
| 0402 | R0015~R010 | 1.15±0.05 | 0.65±0.05 | 8.0±0.20 | 1.75±0.10 | 3.5±0.05 | 0.40+0.2/-0 | 0.40±0.05 | 2.0±0.10 | 4.0±0.05 | 40.0±0.20 | 2.0±0.05 |
| 0603 | R001~R024 | 1.80±0.10 | 1.00±0.10 | 8.0±0.20 | 1.75±0.10 | 3.5±0.05 | 0.40+0.2/-0 | 0.40±0.05 | 4.0±0.10 | 4.0±0.10 | 40.0±0.20 | 2.0±0.05 |
| 0805 | R001 | 2.30±0.10 | 1.55±0.10 | 8.0±0.20 | 1.75±0.10 | 3.5±0.05 | 0.60+0.2/-0 | 0.60±0.05 | 4.0±0.10 | 4.0±0.10 | 40.0±0.20 | 2.0±0.05 |
| | R0015~R019 | 2.30±0.10 | 1.55±0.10 | 8.0±0.20 | 1.75±0.10 | 3.5±0.05 | 0.40+0.2/-0 | 0.40±0.05 | 4.0±0.10 | 4.0±0.10 | 40.0±0.20 | 2.0±0.05 |
| 1206 | R001~R021 | 3.50±0.20 | 1.90±0.20 | 8.0±0.20 | 1.75±0.10 | 3.5±0.05 | 0.60+0.2/-0 | 0.60±0.05 | 4.0±0.10 | 4.0±0.10 | 40.0±0.20 | 2.0±0.05 |
| 2010 | 5~90 | 5.45±0.10 | 2.90±0.10 | 12.0±0.15 | 1.75±0.10 | 5.5±0.10 | 1.33±0.10 | 0.23±0.05 | 4.0±0.10 | 4.0±0.10 | 40.0±0.20 | 2.0±0.10 |
| 2512 | R003~R100 | 6.75±0.10 | 3.50±0.10 | 12.0±0.15 | 1.75±0.10 | 5.5±0.10 | 1.30±0.10 | 0.20±0.05 | 4.0±0.10 | 4.0±0.10 | 40.0±0.20 | 2.0±0.10 |
| 2725 | R0002~R003 | 7.15±0.10 | 6.75±0.10 | 12.0±0.15 | 1.75±0.10 | 5.5±0.10 | 1.95±0.10 | 0.25±0.05 | 8.0±0.10 | 4.0±0.10 | 40.0±0.20 | 2.0±0.10 |
| 4527 | R005~R100 | 11.80±0.10 | 7.20±0.10 | 24.0±0.15 | 1.75±0.10 | 11.5±0.10 | 2.00±0.10 | 0.30±0.10 | 12.0±0.10 | 4.0±0.10 | 40.0±0.20 | 2.0±0.10 |

8.3 Packaging model :

| Type | Tape width | Max. Packaging Quantity (pcs/reel) | | | | |
|------|------------|------------------------------------|-----------|-----------------------|-----------|------------|
| | | Carrier Tape | | Embossed Plastic Type | | |
| | | 2mm pitch | 4mm pitch | 4mm pitch | 8mm pitch | 12mm pitch |
| 0402 | 8mm | 10,000pcs | -- | -- | -- | -- |
| 0603 | 8mm | -- | 5,000pcs | -- | -- | -- |
| 0805 | 8mm | -- | 5,000pcs | -- | -- | -- |
| 1206 | 8mm | -- | 5,000pcs | -- | -- | -- |
| 2010 | 12mm | -- | -- | 2,000pcs | -- | -- |
| 2512 | 12mm | -- | -- | -- | 4,000pcs | -- |
| 2725 | 12mm | -- | -- | -- | 1,000pcs | -- |
| 4527 | 24mm | -- | -- | -- | -- | 500pcs |

8.4 Reel Dimensions :

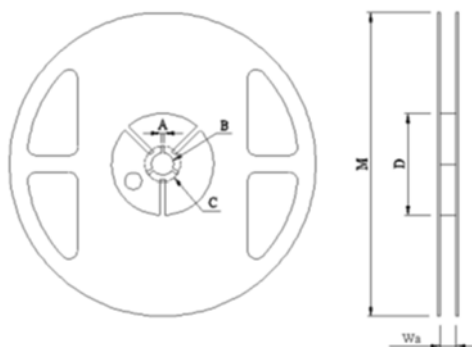

Unit : mm

| Item | Reel Type / Tape | Wa | M | A | B | C | D |
|--------------|------------------------|------------|-----------|-----------|------------|------------|------------|
| 0402 | 7" reel for 8 mm tape | 9.0±0.5 | 178±2.0 | 2.0±0.5 | 13.5±0.5 | 21.0±0.5 | 60.0±1.0 |
| 0603 | 7" reel for 8 mm tape | 9.0±0.5 | 178±2.0 | 2.0±0.5 | 13.5±0.5 | 21.0±0.5 | 60.0±1.0 |
| 0805 1206 | 7" reel for 8 mm tape | 9.0±0.5 | 178±2.0 | 2.0±0.5 | 13.5±0.5 | 21.0±0.5 | 60.0±1.0 |
| 2010 2512 | 7" reel for 12 mm tape | 13.8±0.5 | 178±2.0 | 2.0±0.5 | 13.5±0.5 | 21.0±0.5 | 60.0±1.0 |
| 2725 | 7" reel for 12 mm tape | 13.8±0.5 | 178±2.0 | 2.0±0.5 | 13.5±0.5 | 21.0±0.5 | 80.0±1.0 |
| 4527 | 7" reel for 24 mm tape | 25.0 ± 1.0 | 178 ± 2.0 | 2.0 ± 0.5 | 13.2 ± 0.5 | 17.7 ± 0.5 | 60.0 ± 1.0 |

8.5 Inner Box :

| Reel Number (for 8 mm tape) | Reel Number (for 12 mm tape) | Reel Number (for 24 mm tape) | D Dimension (mm) |
|--------------------------------|----------------------------------|----------------------------------|---------------------|
| 1 | - | - | 12 |
| 2 | 1 | - | 24 |
| 3 | 2 | 1 | 36 |
| 4 | - | - | 48 |
| 5 | 3 | 2 | 60 |
| 6 | 4 | - | 72 |
| 7 | - | 3 | 84 |
| 8 | - | - | 96 |
| 9 | - | - | 108 |
| 10 | - | 4 | 120 |

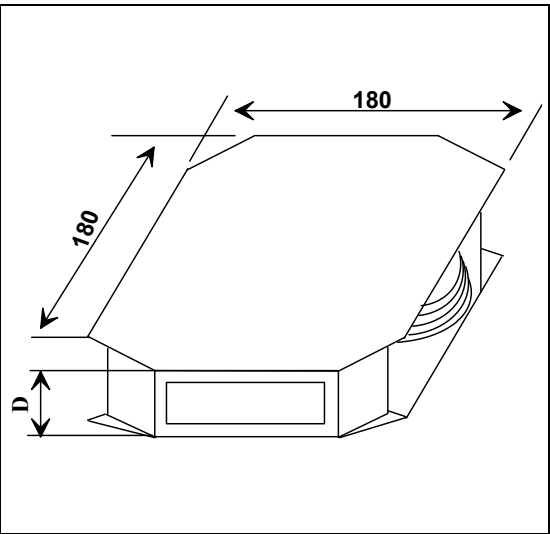

8.6 Box :

| 9R/10R Inner Box Number | L(mm) | W(mm) | H(mm) |
|----------------------------|-------|-------|-------|
| 2 | 272 | 205 | 210 |
| 4 | 375 | 280 | 210 |
| 6 | 395 | 380 | 210 |
| 8 | 544 | 380 | 210 |

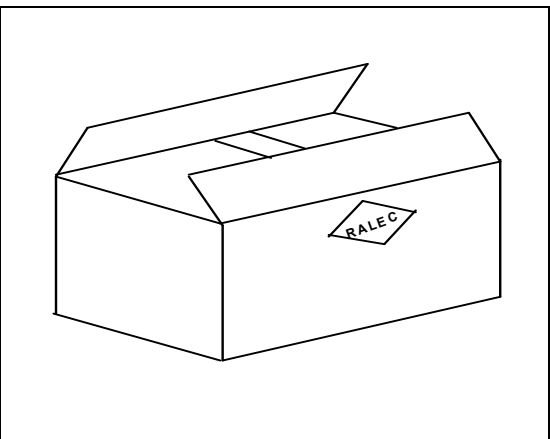

8.7 Box(For China)

| 9R/10R Inner Box Number | L(mm) | W(mm) | H(mm) |
|----------------------------|-------|-------|-------|
| 2 | 272 | 205 | 210 |
| 4 | 375 | 280 | 210 |
| 6 | 395 | 380 | 210 |
| 8 | 544 | 380 | 210 |

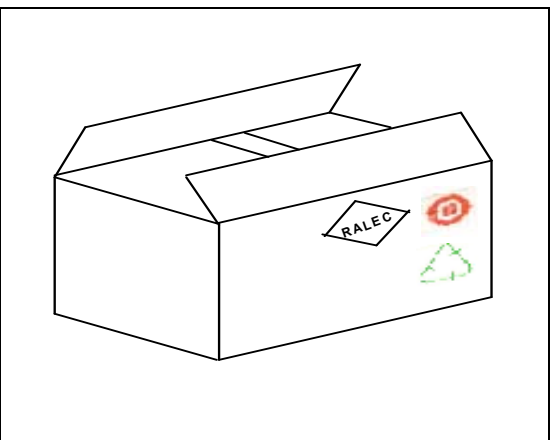

9 Technical application notes: (This is for recommendation, please customer perform adjustment according to actual application)

9.1 Recommend soldering method :

9.1.1 This product is applicable to IR-reflow process only.(Infrared Reflow)

Typical examples of soldering processes that provides reliable joints without any damage are given in below :

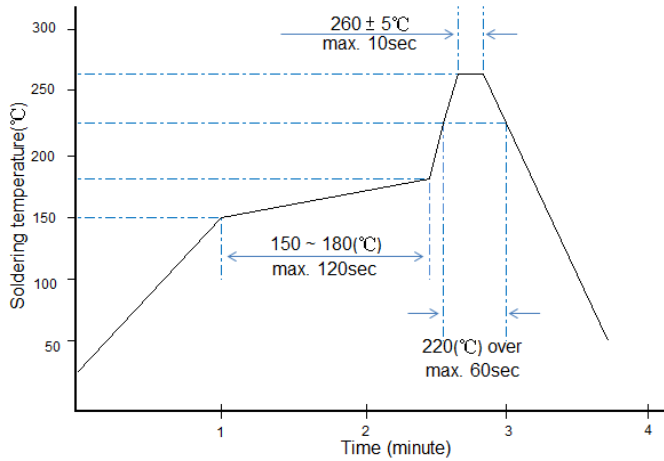

Recommended IR Reflow Soldering Profile
MEET J-STD-020D

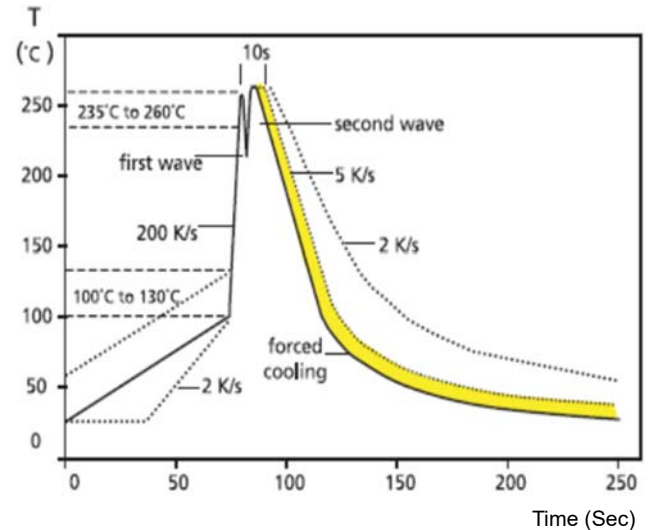

Recommended double-wave Soldering Profile
Typical values (solid line)
Process limits (dotted line)

9.1.2 Soldering Iron: temperature 350°C±10°C , dwell time shall be less than 3 sec.

9.2 Recommend Land Pattern :

When a component is soldered, the resistance after soldering changes slightly depending on the size of the soldering area and the amount of soldering. When designing a circuit, it is necessary to consider the effect of a decrease or increase in its resistance.

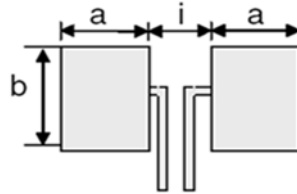

| Type | Power Rating (Watts) | Resistance Range (mΩ) | Dimensions - in millimeters | | |
|------|----------------------|-----------------------|-----------------------------|------|------|
| | | | a | b | i |
| 0402 | 0.2 | 1.5 ~ 2 | 0.65 | 0.50 | 0.50 |
| | | $3 \leq R \leq 4$ | | | |
| | | 5 | | | |
| | | 10 | | | |
| 0603 | 0.33 | 1 ~ 24 | 1.00 | 1.27 | 0.50 |
| 0805 | 0.5 | 1~19 | 1.45 | 1.78 | 0.66 |
| 1206 | 0.5 1 | $1 \leq R < 3$ | 1.65 | 2.18 | 0.60 |
| | | $3 \leq R < 4$ | 1.65 | 2.18 | 0.90 |
| | | $4 \leq R \leq 21$ | 1.65 | 2.18 | 1.00 |
| 2010 | 1 | 5~90 | 2.29 | 2.92 | 2.41 |
| | 1.5 | 5~60 | | | |
| | 2 | 5~10 | | | |
| 2512 | 1&1.5 | 3~100 | 2.11 | 3.68 | 3.18 |
| | 2 | 3 ~ 70 | | | |
| | 3 | 3 ~ 10 | | | |
| 2725 | 4& 5 | 0.20 ~ 3.0 | 3.18 | 6.86 | 1.32 |
| 4527 | 5 | 5 | 5.80 | 8.74 | 3.51 |
| | | 5.1~100 | 4.15 | | 6.81 |

9.3 Recommend dispensing method (for LRH2512)

9.3.1 The structure of RALEC metal alloy resistor that both side of main body would be thinner due to process factor (as the photo below).

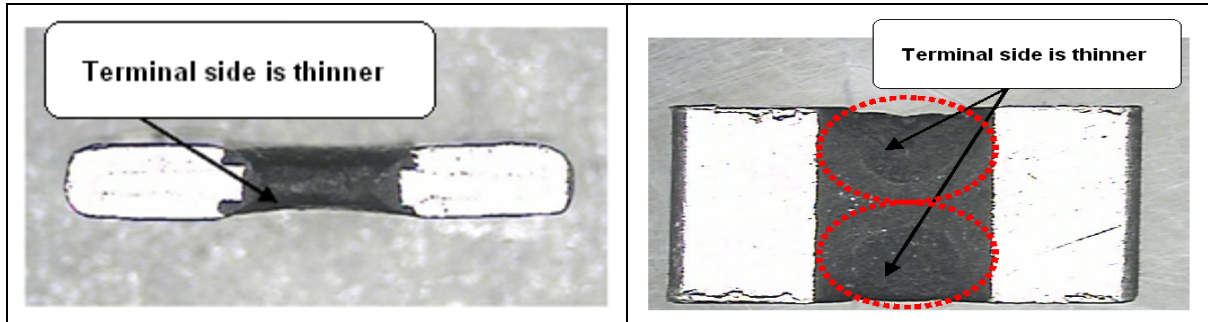

9.3.2 When customer performs wave solder process shall take note on the dispensing gap.

If the gap between two dispensing is over, the red-glue will not adhesive the resistor body and be dropped out (as photo 1). Therefore, we suggest customer to narrow down the dispenser gap (as photo 2), or dispenser on the body center (as photo 3)

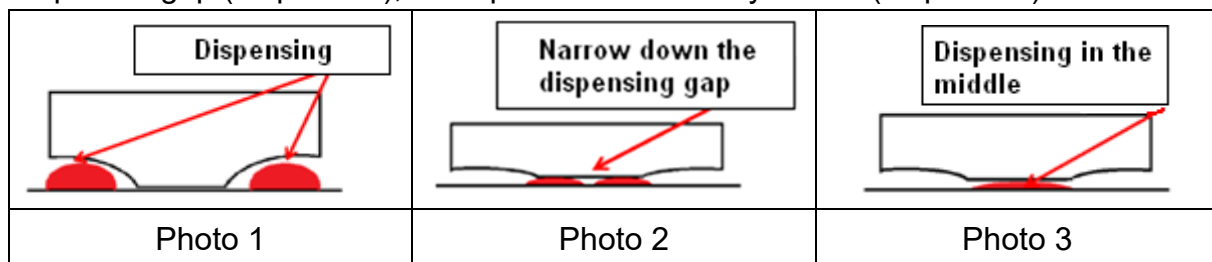

9.4 Product warranted solder area

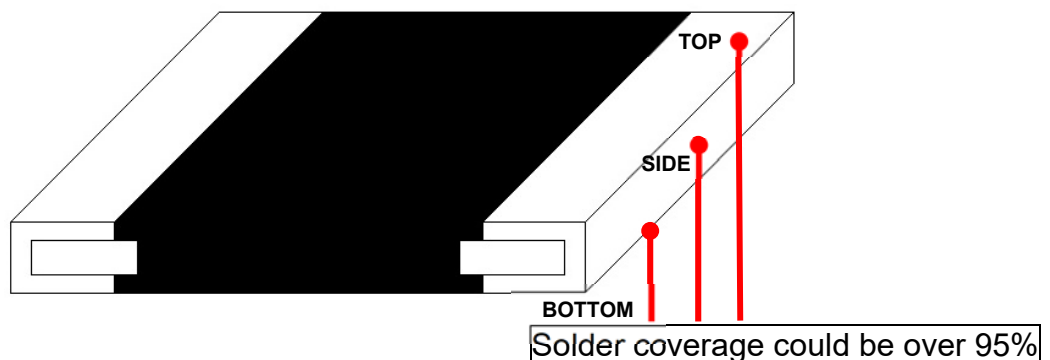

9.5 Environment Precautions :

This specification product is for general electronic use, RALEC will not be responsible for any damage, cost or loss caused by using this specification product in any special environment. If other applications need to confirm with RALEC.

If consumer intends to use our Company product in special environment or condition (including but not limited to those mentioned below), then will need to make individual recognition of product features and reliability accordingly.

- (a) Used in high temperature and humidity environment
- (b) Exposed to sea breeze or other corrosive gas, such as Cl_2 、 H_2S 、 NH_3 、 SO_2 and NO_2 .
- (c) Used in non-verified liquids including water, oil, chemical and organic solvents.
- (d) Using non-verified resin or other coating material to seal or coat our Company product.
- (e) After soldering, it is necessary to use water-soluble detergents to clean residual solder fluxes, even though no-clean fluxes are recommended.

9.6 Momentary Overload Precautions :

The product might be out of function when momentary overloaded. Please make sure to avoid momentary overloading while using and preserving.

9.7 Operation and Processing Precautions :

- (a) Avoid damage to the edge of resistor and protective layer caused by mechanical stress.
- (b) Handle with care when printing circuit board (PCB) is divided or fixed on support body, because bending of printing circuit board (PCB) mounting will make mechanical stress for resistors.
- (c) Make sure the power rating is under the limit when using the resistor. When power rating is over the limit, the resistor will be overloaded. There might be machinery damage due to the climbing temperature.
- (d) If the resistor will be exposed under massive impact load (shock wave) in a short period of time, the working environment must be set up well before use.
- (e) Please make evaluation and confirmation when the product is well used in your company and have a through consideration of it's fail-safe design to ensure the system safety.

10 Storage and transportation requirement:

- 10.1 The temperature condition must be controlled at $25\pm 5^{\circ}\text{C}$, the R.H. must be controlled at $60\pm 15\%$. The stock can maintain quality level in two years.
- 10.2 Please avoid the mentioned harsh environment below when storing to ensure product performance and its' weld ability. Places exposed to sea breeze or other corrosive gas, such as Cl_2 、 H_2S 、 NH_3 、 SO_2 and NO_2 .
- 10.3 When the product is moved and stored, please ensure the correct orientation of the box. Do not drop or squeeze the box. Otherwise, the electrode or the body of the product may be damaged.

11 Inductance

Inductance characteristics: $< 10\text{nH}$ (Circuit frequency is below 1MHz)

12 Stock period:

The temperature condition must be controlled at $25\pm 5^{\circ}\text{C}$, the R.H. must be controlled at $60\pm 15\%$. The stock can maintain quality level in two years.

13 Attachments

- 13.1 Document Revise Record (QA-QR-027)

Legal disclaimer

RALEC, its distributors and agents (collectively, "RALEC"), hereby disclaims any and all liabilities for any errors, inaccuracies or incompleteness contained in any product related information, including but not limited to product specifications, datasheets, pictures and/or graphics. RALEC may make changes, modifications and/or improvements to product related information at any time and without notice.

RALEC makes no representation, warranty, and/or guarantee about the fitness of its products for any particular purpose or the continuing production of any of its products. To the maximum extent permitted by law, RALEC disclaims (i) any and all liability arising out of the application or use of any RALEC product, (ii) any and all liability, including without limitation special, consequential or incidental damages, and (iii) any and all implied warranties, including warranties of fitness for a particular purpose, non-infringement and merchantability.

RALEC defined this product is for general electrical use , not design for any application for automotive electrical ,life-saving or life support equipment, or any application which may inflict casualties if RALEC product failure occurred. When consumer is using or selling products of RALEC without having discussion with the sales representatives and specifically stated the applicability mentioned above in a written form, then the client need to take a full responsibility and agree to protect RALEC from punishment and damage.

Information provided here is intended to indicate product specifications only. RALEC reserves all the rights for revising this content without further notification, as long as products are unchanged. Any product change will be announced by ECN.

单击下面可查看定价，库存，交付和生命周期等信息

[>>RALEC\(旺途\)](#)