

<b>VDS</b>	<b>RDS(on)</b>	<b>ID@25°C</b>
1200V	25mΩ	90A

**Applications:**

- Solar Inverters
- Switch Mode Power Supplies
- High Voltage DC/DC Converters
- EV Charging
- Motor Drives

**Features:**

- High Blocking Voltage with Low On-Resistance
- High Speed Switching with Low Capacitances
- Easy to Parallel and Simple to Drive
- Avalanche Ruggedness

**Benefits:**

- Higher System Efficiency
- Reduced Cooling Requirements
- Increased Power Density
- Increased System Switching Frequency

**Ordering Information**

Part Number	Package	Marking	Packing	Qty.
RSM120025Z	TO-247-4	RSM120025Z	Tube	30 PCS

**Maximum Ratings** (T<sub>J</sub>= 25°C unless otherwise specified)

Symbol	Parameter	Value	Unit	Test Conditions	Note
VDSmax	Drain - Source Voltage	1200	V	VGS=0V, ID =100μA	
VGSmax	Gate - Source Voltage	-10/+2 5	V	Absolute maximum values	
VGSop	Gate - Source Voltage	-5/+20	V	Recommended operational values	
ID	Continuous Drain Current	90 60	A	VGS=20V, TC =25°C VGS=20V, TC =100°C	
ID(pulse)	Pulsed Drain Current	200	A	Pulse width tp limited by TJmax	
PD	Power Dissipation	370	W	TC =25°C, TJ =150°C	
TL	Solder Temperature	260	°C		
TJ, Tstg	Operating Junction and Storage Temperature	-40 to + 150	°C		

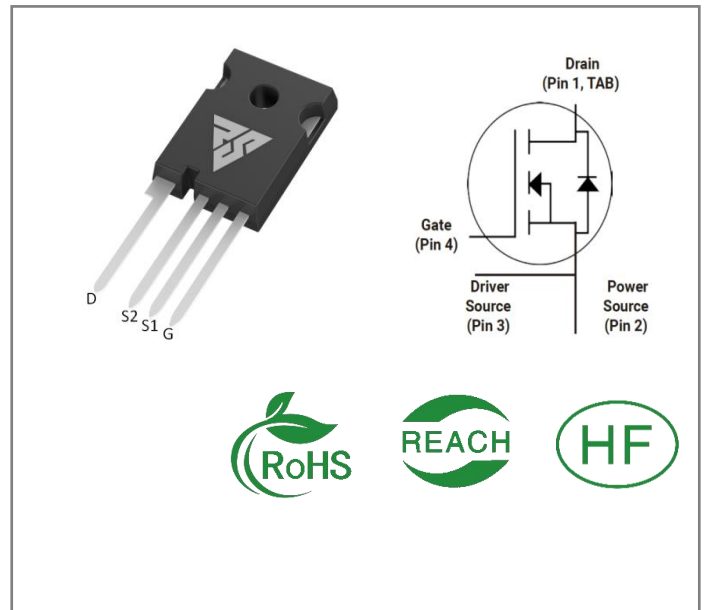

**Electrical Characteristics** (T<sub>J</sub>= 25°C unless otherwise specified)

Symbol	Parameter	Min.	Typ.	Max.	Unit	Test Conditions	Note
V(BR)DSS	Drain-Source Breakdown Voltage	1200			V	VGS=0V, ID =100μA	
VGS(th)	Gate Threshold Voltage	2.0	2.4	4.0	V	VGS= VDS, IDS=15mA, TC =25°C	
			1.8		V	VGS= VDS, IDS=15mA, TC =150°C	
IDSS	Zero Gate Voltage Drain Current		1	100	μA	VDS= 1200V, VGS=0V	
IGSS	Gate-Source Leakage Current			250	nA	VGS=20V, VDS= 0V	
RDS(on)	Drain-Source on-state Resistance		25	34	mΩ	VGS=20V, ID =50A, TC =25°C	
			43			VGS=20V, ID =50A, TC =150°C	
Ciss	Input Capacitance		3600		pF	VGS=0V, VDS=1000 V, f=1MHz, VAC=25 mV	
Coss	Output Capacitance		24				
Crss	Reverse Transfer Capacitance		16				
EON	Turn-On Switching Energy		1800		μJ	VDS =800V, VGS =-5/20V, ID = 30A, RG(ext) = 2.5Ω, L= 200μH	
EOFF	Turn-Off Energy		1500				
td(on)	Turn-On Delay Time		16		ns	VDS =800V, VGS =-5/20 V ID = 30A, RG(ext)=2.5 Ω , RL =2.5Ω	
tr	Rise Time		16.2				
td(off)	Turn-Off Delay Time		33				
tf	Fall Time		7.8				
RG(int)	Internal Gate Resistance		2.0		Ω	f=1 MHz, VAC=25mV	
Qgs	Gate to Source Charge		54		nC	VDS=800V, VGS=-5/20V ID =30A	
Qgd	Gate to Drain Charge		29		nC		
Qg	Total Gate Charge		195				

**Reverse Diode Characteristics** (T<sub>J</sub>= 25°C unless otherwise specified)

Symbol	Parameter	Typ.	Max	Unit	Test Conditions	Note
VSD	Diode Forward Voltage	3.6		V	V <sub>GS</sub> =-5V, I <sub>SD</sub> =25 A, T <sub>J</sub> = 25°C	
		3.3		V	V <sub>GS</sub> =-5V, I <sub>SD</sub> =25 A, T <sub>J</sub> = 150°C	
I <sub>S</sub>	Continuous Diode Forward Current		90	A	V <sub>GS</sub> =-5V, T <sub>C</sub> = 25°C	
t <sub>rr</sub>	Reverse Recovery time	55		ns	I <sub>SD</sub> = 25A, V <sub>R</sub> = 800V	
Q <sub>rr</sub>	Reverse Recovery Charge	320		nC		
I <sub>rrm</sub>	Peak Reverse Recovery Current	10.7		A		

**Thermal Characteristics** (T<sub>J</sub>= 25°C unless otherwise specified)

Symbol	Parameter	Typ.	Unit	Test Conditions	Note
R <sub>θJC</sub>	Thermal Resistance from Junction to Case	0.25	°C/W		
R <sub>θJA</sub>	Thermal Resistance From Junction to Ambient	40			

**Typical Feature Curve**

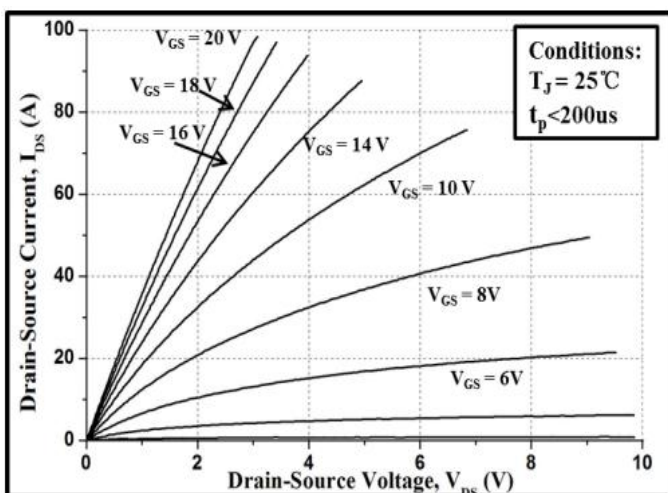

Figure 1. Typical Output Characteristics T<sub>J</sub>=25°C

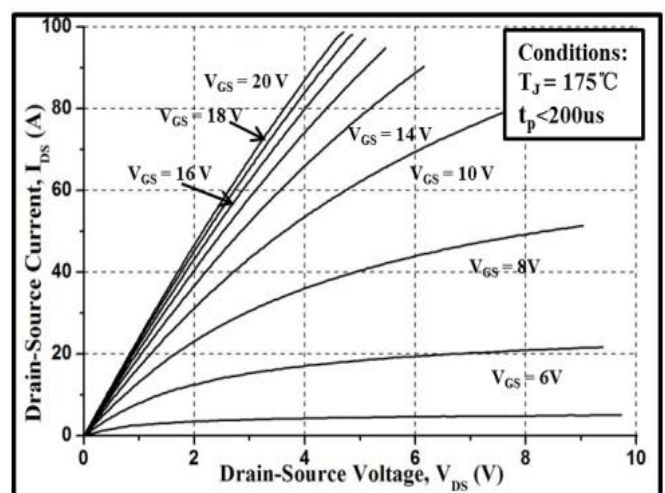

Figure 2. Typical Output Characteristics T<sub>J</sub>=175°C

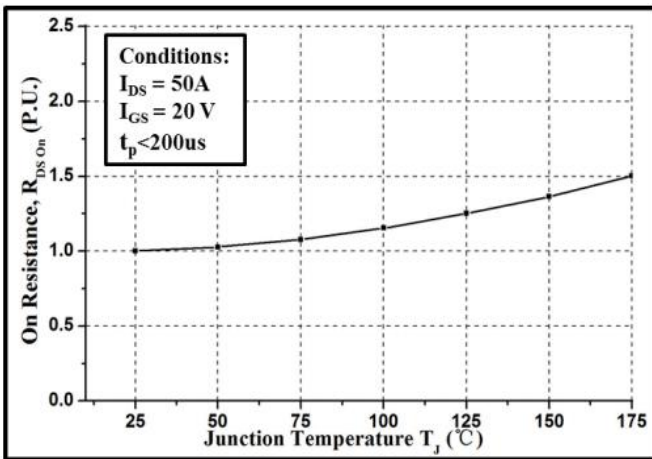

Figure 3. Normalized On-Resistance vs. Temperature

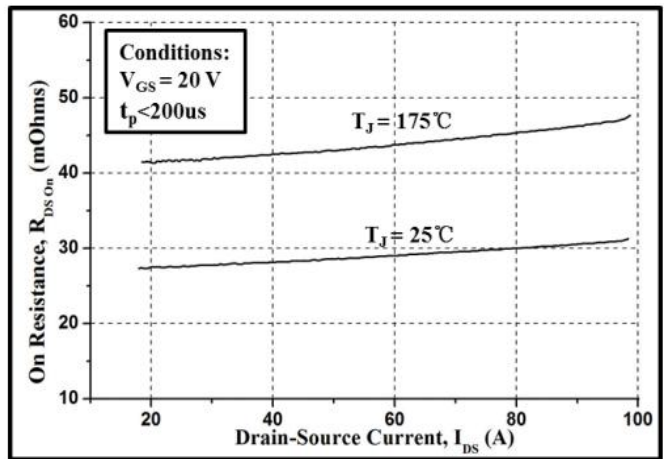

Figure 4. On-Resistance vs. Drain Current

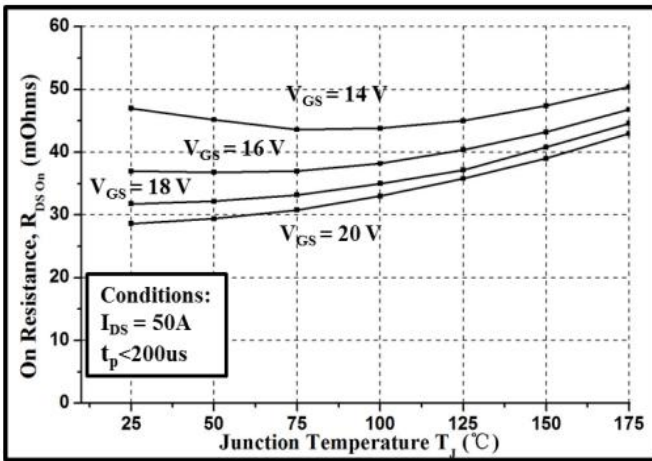

Figure 5. On-Resistance vs. Temperature

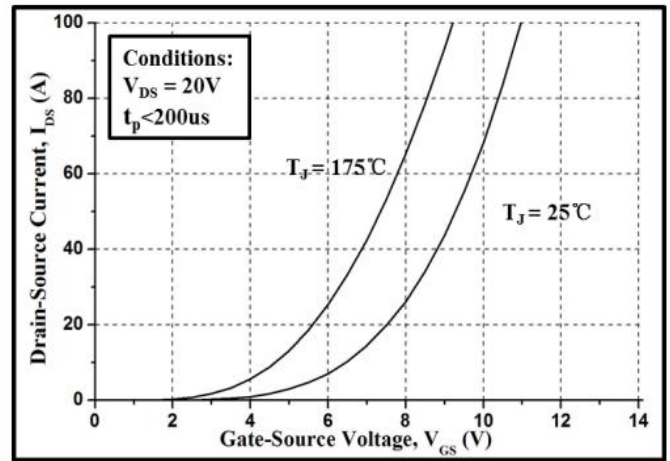

Figure 6. Typical Transfer Characteristics

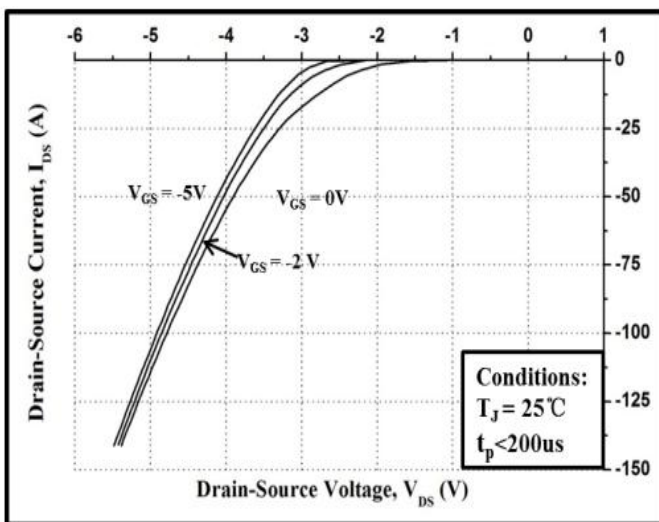

Figure 7. Body Diode Characteristics at 25°C

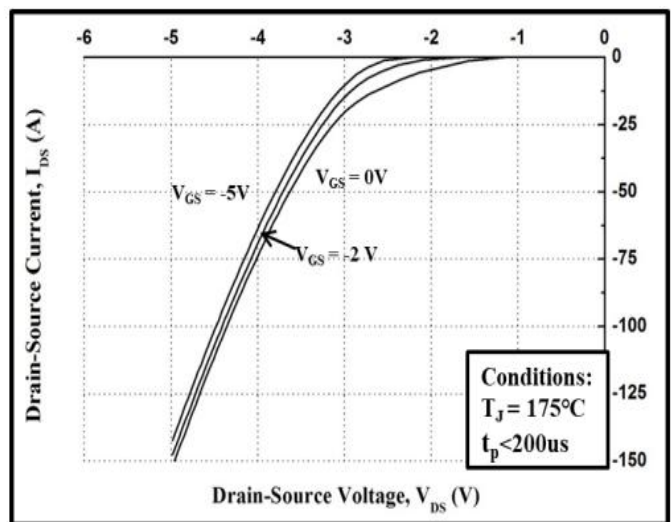

Figure 8. Body Diode Characteristics at 175°C

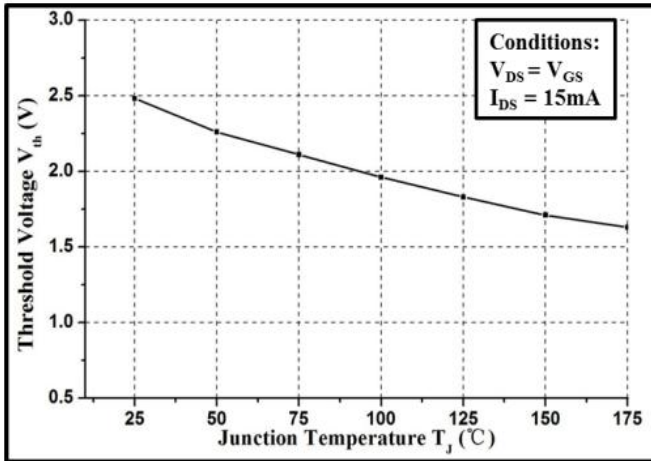

Figure 9. Gate Threshold Voltage vs. Temperature

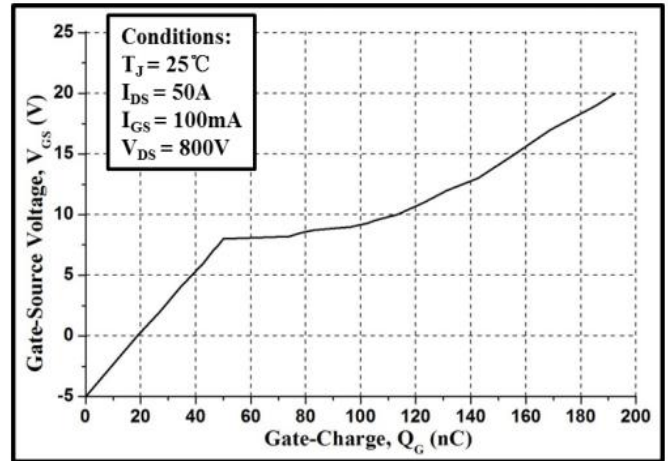

Figure 10. Gate Charge Characteristic

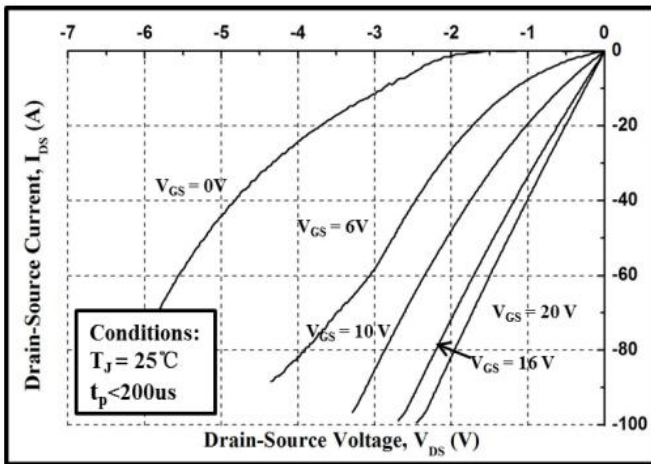

Figure 11. 3<sup>rd</sup> Quadrant Characteristics at 25° C

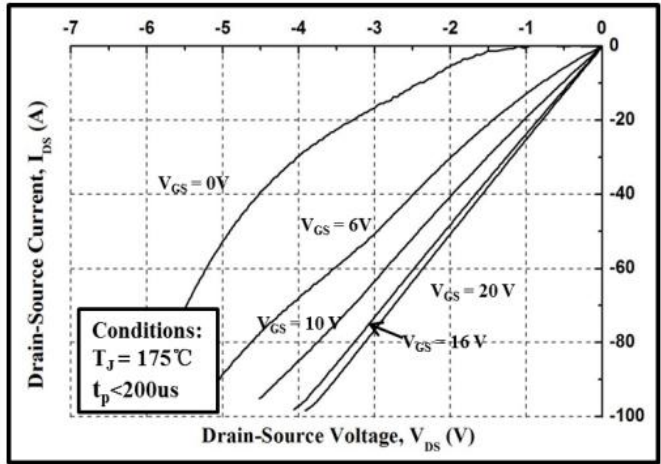

Figure 12. 3<sup>rd</sup> Quadrant Characteristics at 175° C

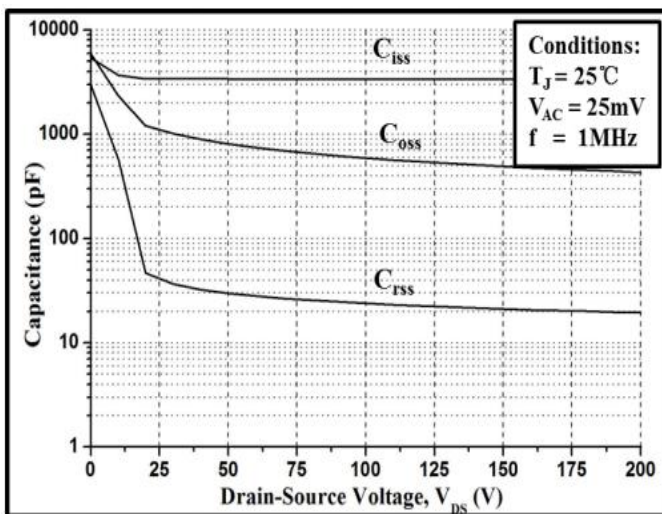

Figure 13. Capacitances vs. Drain-Source Voltage

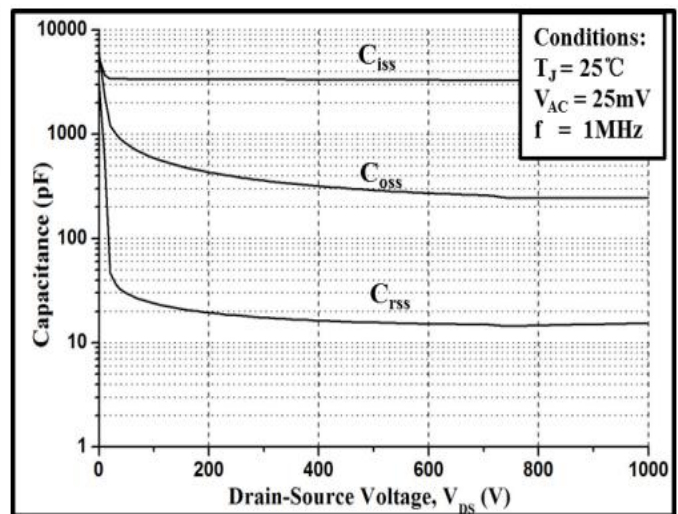
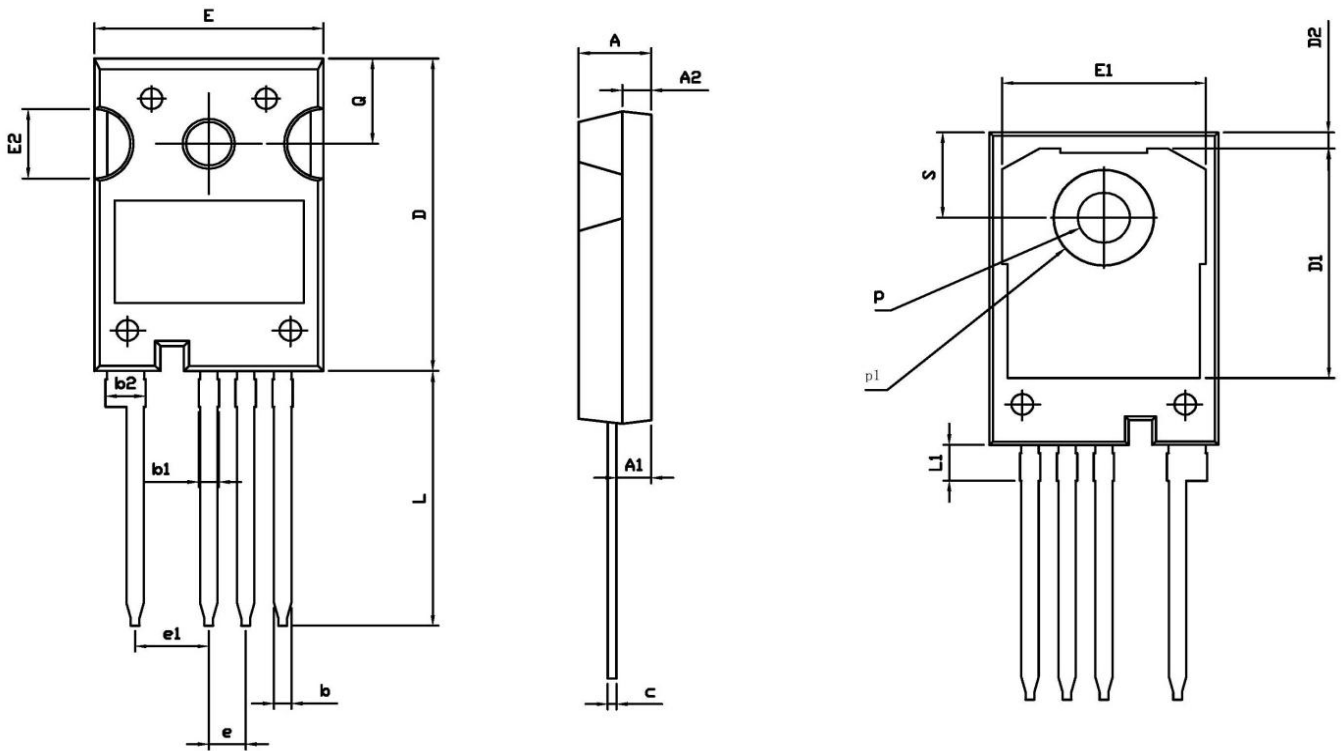
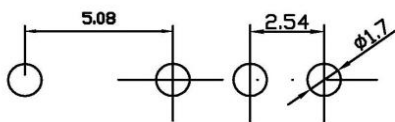

Figure 14. Capacitances vs. Drain-Source Voltage

Package outline drawing(TO-247-4 Unit: mm)



RECOMMENDED LAND PATTERN



UNIT: mm

	MIN	NOM	MAX
A	4.80	5.00	5.20
A1	2.25	2.40	2.45
A2	1.85	2.00	2.15
b	1.05	1.20	1.35
b1	1.00	1.30	1.60
b2	2.35	2.65	2.95
c	0.50	0.60	0.70
D	22.34	22.54	22.74
D1	16.00	16.50	17.00
D2	0.97	1.17	1.37
e	2.34	2.54	2.74
e1	4.88	5.08	5.28
E	15.60	15.80	16.00
E1	13.50	14.00	14.50
E2	4.80	5.00	5.20
L	18.08	18.38	18.68
L1	2.38	2.58	2.78
p	3.50	3.60	3.70
p1	6.60	6.80	7.00
Q	6.00	6.15	6.30
S	6.00	6.15	6.30

**Disclaimers:**

Reasunos Semiconductor Technology Co.Ltd (Reasunos) reserves the right to make changes without notice in order to improve reliability,function or design and to discontinue any product or service without notice .Customers should obtain the latest relevant information before orders and should verify that such information in current and complete.All products are sold subject to Reasunos's terms and conditions supplied at the time of orderacknowledgement.

Reasunos Semiconductor Technology Co.Ltd warrants performance of its hardware products to the specifications at the time of sale.Testing,reliability and quality control are used to the extene Reasunos deems necessary to support this warrantee. Except where agreed upon by contr- actual agreement,testing of all parameters of each product is not necessarily performed.

Reasunos Semiconductor Technology Co.Ltd does not assume any liability arising from the use of any product or circuit designs described herein.Customers are responsible for their products and applications using Reasunos's components.To minimize risk,customers must provide adequate design and operating safeguards.

Reasunos Semiconductor Technology Co.Ltd does not warrant or convey any license eith- er expressed or implied under its patent rights,nor the rights of others.Reproduction of inform- ation in Reasunos's data sheets or data books is permissible only if reproduction is without modification oralteration.Reproduction of this information with any alteration is an unfair and deceptive business practice. Reasunos Semiconductor Technology Co.Ltd is not responsi- ble or liable for such altered documentation.

Resale of Reasunos's products with statements different from or beyond the parameters stated by Reasunos Semiconductor Technology Co.Ltd for that product or service voids all exp- ress or implied warranties for the associated Reasunos's product or service and is unfair and deceptive business practice. Reasunos Semiconductor Technology Co.Ltd is not responsi- ble or liable for such statements.

**Life Support Policy:**

Reasunos Semiconductor Technology Co.Ltd's Products are not authorized for use as cri- tical components in life support devices or systems without the expressed written approval of Reasunos Semiconductor Technology Co.Ltd.

As used herein:

1. Life support devices or systems are devices or systems which: a.are intended for surgical implant into the human body, b.support or sustain life, c.whose failuer to when properly used in accordance with instructions for used provided in the laeling,can be reasonably expected to result in significant injury to the user.

2.A critical component is any component of a life support device or system whose failure to system whose failure to perform can be reasonably expected to cause the failure of the life support device or system,or to affect its safety or effectiveness.

单击下面可查看定价，库存，交付和生命周期等信息

[>>REASUNOS\(瑞森\)](#)