

**SURFACE MOUNT GLASS PASSIVATED
HIGH EFFICIENCY SILICON RECTIFIER**
VOLTAGE RANGE 50 to 1000 Volts CURRENT 3.0 Ampere

FEATURES

- * Glass passivated device
- * Ideal for surface mounted applications
- * Low leakage current
- * Metallurgically bonded construction
- * Mounting position: Any
- * Weight: 0.24 gram

MECHANICAL DATA

- * Epoxy: Device has UL flammability classification 94V-O



DO-214AB

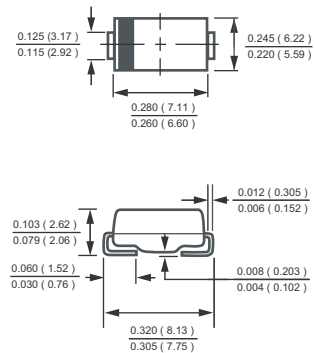

Dimensions in inches and (millimeters)

MAXIMUM RATINGS AND ELECTRICAL CHARACTERISTICS

Ratings at 25 °C ambient temperature unless otherwise specified.
resistive or inductive load.

MAXIMUM RATINGS (@ TA=25 °C unless otherwise noted)

RATINGS	SYMBOL	HFM301	HFM302	HFM303	HFM304	HFM305	HFM306	HFM307	HFM308	UNITS
Maximum Recurrent Peak Reverse Voltage	V_{RRM}	50	100	200	300	400	600	800	1000	Volts
Maximum RMS Voltage	V_{RMS}	35	70	140	210	280	420	560	700	Volts
Maximum DC Blocking Voltage	V_{DC}	50	100	200	300	400	600	800	1000	Volts
Maximum Average Forward Rectified Current at $T_L = 105^\circ\text{C}$	I_O	3.0								Amps
Peak Forward Surge Current 8.3 ms single half sine-wave superimposed on rated load (JEDEC method)	I_{FSM}	200				150				Amps
Current Squarad Time	I^2t	165.9				93.3				A^2/Sec
Typical Thermal Resistance (Note 1)	$R_{\theta JL}$	15								$^\circ\text{C}/\text{W}$
Typical Thermal Resistance (Note 1)	$R_{\theta JA}$	60								$^\circ\text{C}/\text{W}$
Typical Junction Capacitance (Note 2)	C_J	70				50				pF
Operating Temperature Range	T_J	-55 to + 150								$^\circ\text{C}$
Storage Temperature Range	T_{STG}	-55 to + 150								$^\circ\text{C}$

ELECTRICAL CHARACTERISTICS (@TA=25 °C unless otherwise noted)

CHARACTERISTICS	SYMBOL	HFM301	HFM302	HFM303	HFM304	HFM305	HFM306	HFM307	HFM308	UNITS
Maximum Instantaneous Forward Voltage at 3.0A DC	V_F	1.0		1.3		1.7				Volts
Maximum Full Load Reverse Current, Full cycle Average $T_A = 55^\circ\text{C}$	I_R	25								μA
Maximum Average Reverse Current @ $T_A = 25^\circ\text{C}$		0.3								μA
at Rated DC Blocking Voltage @ $T_A = 150^\circ\text{C}$		200								μA
Maximum Reverse Recovery Time (Note 4)	t_{rr}	50				75				nSec

- NOTES : 1. Thermal Resistance : Mounted on PCB.
2. Measured at 1 MHz and applied reverse voltage of 4.0 volts.
3. ROHS compliant
4. Test Conditions: $I_F = 0.5\text{A}$, $I_R = -1.0\text{A}$, $I_{RR} = -0.25\text{A}$.

2019-11
REV:E

RATING AND CHARACTERISTICS CURVES (HFM301 THRU HFM308)

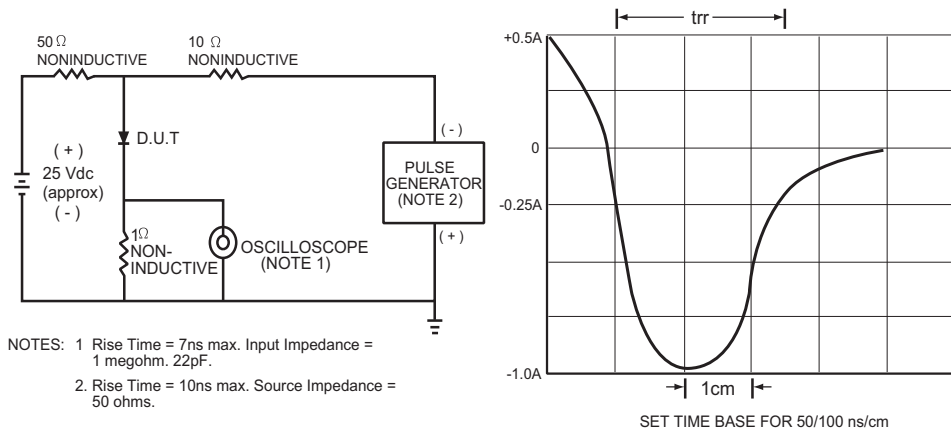

FIG.1 TEST CIRCUIT DIAGRAM AND REVERSE RECOVERY TIME CHARACTERISTIC

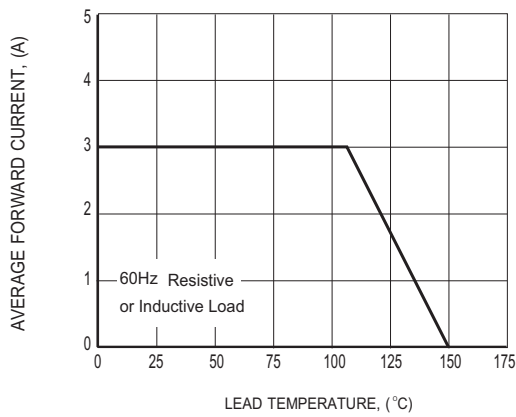

FIG.2 TYPICAL FORWARD CURRENT DERATING CURVE

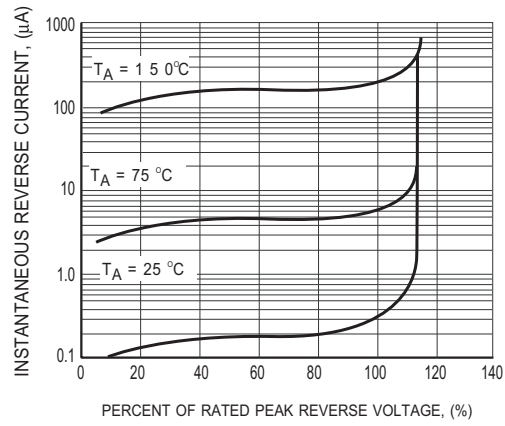

FIG.3 MAXIMUM REVERSE CHARACTERISTICS

RECTRON

RATING AND CHARACTERISTICS CURVES (HFM301 THRU HFM308)

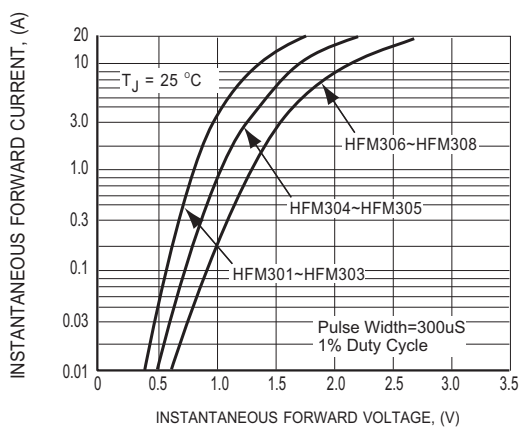

FIG.4 MAXIMUM INSTANTANEOUS FORWARD CHARACTERISTICS

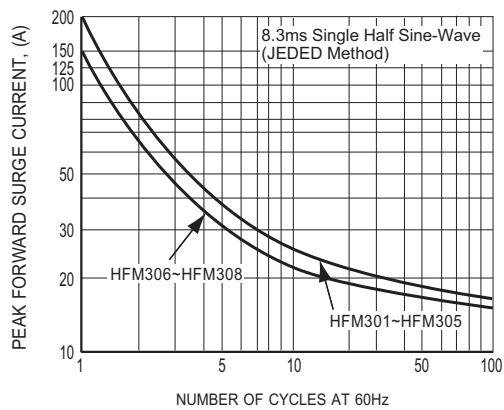

FIG.5 MAXIMUM NON-REPETITIVE FORWARD SURGE CURRENT

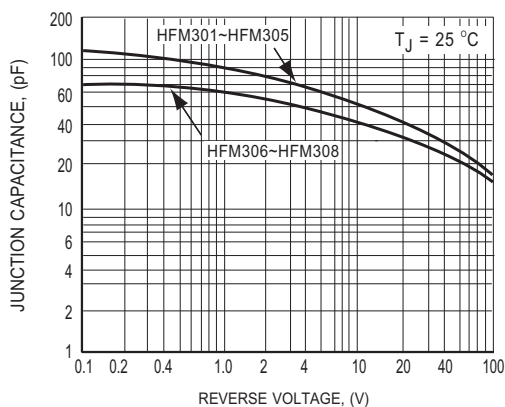
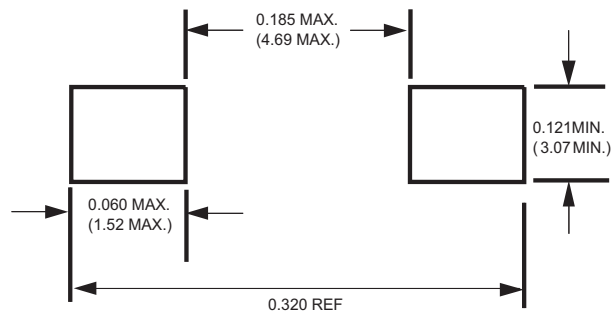

FIG.6 TYPICAL JUNCTION CAPACITANCE



Mounting Pad Layout



Dimensions in inches and (millimeters)



Marking Description

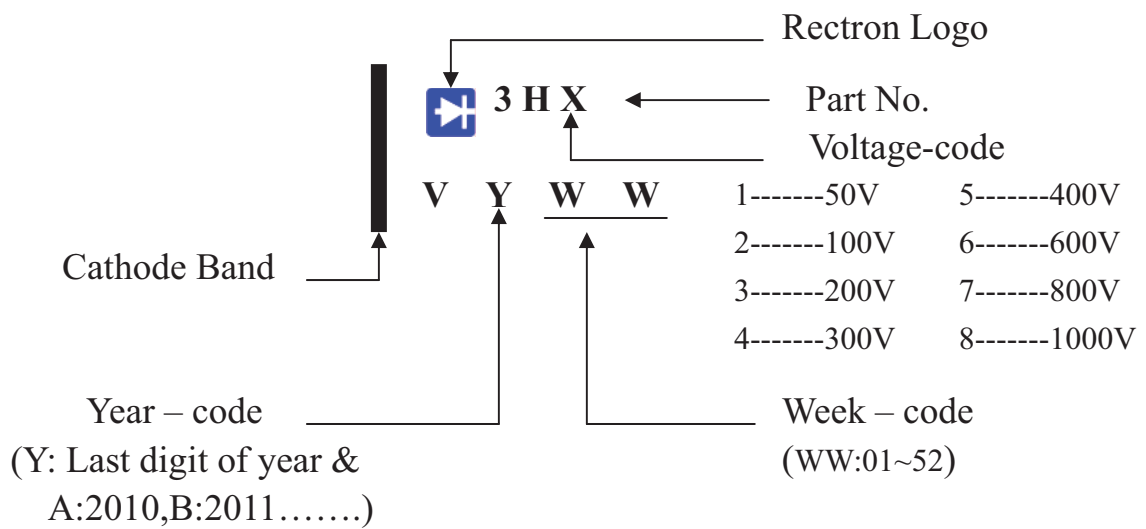

PACKAGING OF DIODE AND BRIDGE RECTIFIERS

REEL PACK

PACKAGE	PACKING CODE	EA PER REEL	EA PER INNER BOX	COMPONENT SPACE (mm)	TAPE SPACE (mm)	REEL DIA (mm)	CARTON SIZE (mm)	EA PER CARTON	GROSS WEIGHT(Kg)
SMC	-W/-T	3,000	3,000	---	---	330	360*355*360	24,000	11.50

DISCLAIMER NOTICE

Rectron Inc reserves the right to make changes without notice to any product specification herein, to make corrections, modifications, enhancements or other changes. Rectron Inc or anyone on its behalf assumes no responsibility or liability for any errors or inaccuracies. Data sheet specifications and its information contained are intended to provide a product description only. "Typical" parameters which may be included on RECTRON data sheets and/ or specifications can and do vary in different applications and actual performance may vary over time. Rectron Inc does not assume any liability arising out of the application or use of any product or circuit.

Rectron products are not designed, intended or authorized for use in medical, life-saving implant or other applications intended for life-sustaining or other related applications where a failure or malfunction of component or circuitry may directly or indirectly cause injury or threaten a life without expressed written approval of Rectron Inc. Customers using or selling Rectron components for use in such applications do so at their own risk and shall agree to fully indemnify Rectron Inc and its subsidiaries harmless against all claims, damages and expenditures.

单击下面可查看定价，库存，交付和生命周期等信息

[>>RECTRON\(丽正\)](#)