

## Contents

1	Brief Description .....	2
2	Electrical Characteristics .....	3
2.1.	Absolute Maximum Ratings .....	3
2.2.	Operating Conditions .....	4
2.3.	Electrical Parameters .....	5
2.3.1.	Supply Current and System Operation Conditions .....	5
2.3.2.	Analog Front-End Characteristics .....	5
2.3.3.	Temperature Measurement .....	5
2.3.4.	Sensor Diagnostics .....	6
2.3.5.	A2D Conversion .....	6
2.3.6.	DAC and Analog Output (AOUT Pin).....	6
2.3.7.	System Response .....	7
2.4.	Interface Characteristics and Nonvolatile Memory .....	8
2.4.1.	I <sup>2</sup> C™ Interface .....	8
2.4.2.	ZACwire™ One-Wire Interface (OWI at AOUT pin).....	8
2.4.3.	Nonvolatile Memory (NVM).....	9
3	ESD Protection and EMC Specification .....	10
3.1.	ESD Protection .....	10
3.2.	Latch-Up Immunity .....	10
3.3.	Electromagnetic Emission .....	10
3.4.	Conducted Susceptibility (DPI).....	10
4	Reliability and RoHS Conformity .....	11
5	Glossary .....	11
6	Document Revision History .....	12

## List of Figures

Figure 1.1	ZSSC4151 Block Diagram.....	2
------------	-----------------------------	---

## List of Tables

Table 2.1	Absolute Maximum Ratings .....	3
Table 2.2	Operating Conditions .....	4
Table 2.3	Electrical Parameters.....	5
Table 2.4	Interface Characteristics and Nonvolatile Memory .....	8
Table 3.1	Conducted Susceptibility (DPI) Tests .....	10

# 1 Brief Description

The ZSSC4151 sensor signal conditioner (SSC) is a CMOS integrated circuit for highly accurate amplification and sensor-specific correction of bridge sensor signals. Digital compensation of sensor offset, sensitivity, temperature drift, and non-linearity is accomplished via an internal 16-bit RISC microcontroller running a correction algorithm with calibration coefficients stored in an EEPROM.

The ZSSC4151 is adjustable to nearly all bridge sensor types. Measured values are provided at the analog voltage output and at the digital I<sup>2</sup>C™\* or ZACwire™ interface, also referred to as the One-Wire Interface (OWI). The digital interfaces can be used for a simple PC-controlled calibration procedure in order to program a set of calibration coefficients into an on-chip EEPROM. The specific sensor and the ZSSC4151 can be quickly calibrated together. The ZSSC4151 and the calibration equipment communicate digitally, so the noise sensitivity is greatly reduced. Digital calibration helps keep assembly cost low as no trimming by external devices or lasers is needed.

The ZSSC4151 is optimized for automotive environments by overvoltage and reverse-polarity protection circuitry, excellent electromagnetic compatibility, full automotive temperature range, and multiple diagnostic features.

Figure 1.1 provides a block diagram of the ZSSC4151. Refer to section 5 for definitions of abbreviations.

**Figure 1.1 ZSSC4151 Block Diagram**

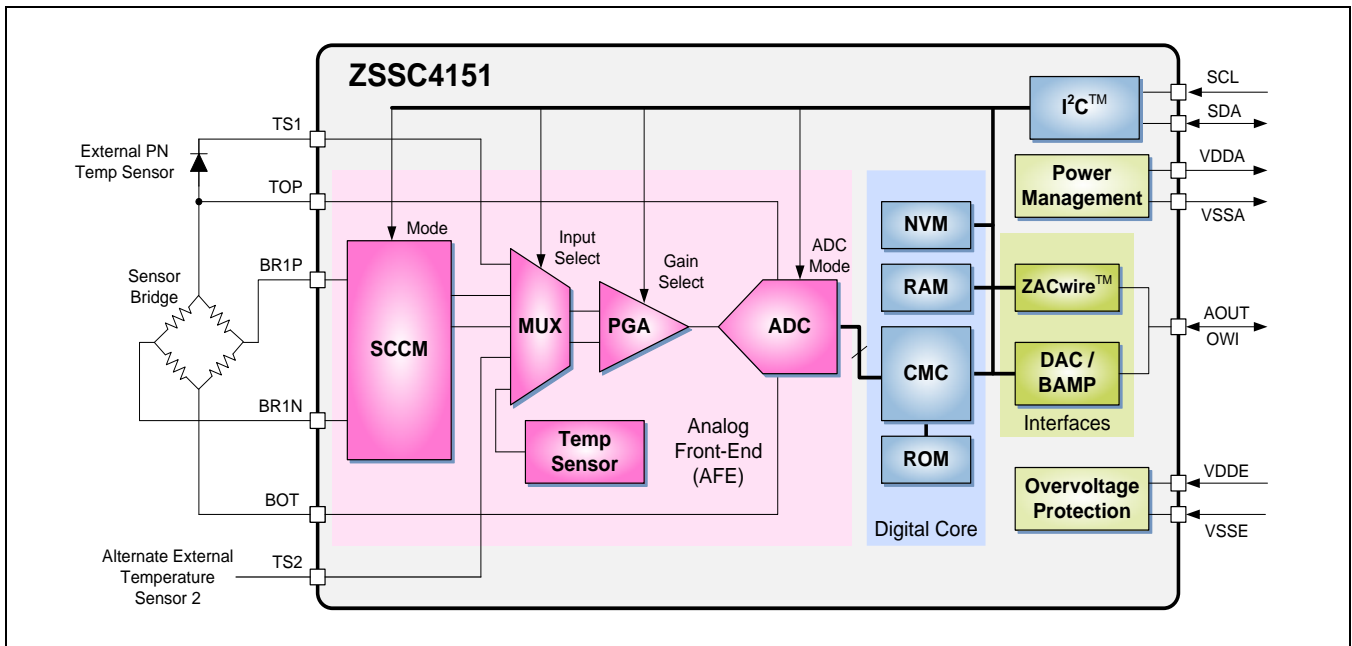

\* I<sup>2</sup>C™ is a trademark of NXP.

## 2 Electrical Characteristics

**Important note:** The *absolute maximum ratings* given in section 2.1 are stress ratings only. The ZSSC4151 might not function or be operable above the *recommended operating conditions*. Stresses exceeding the *absolute maximum ratings* might also damage the device. In addition, extended exposure to stresses above the *recommended operating conditions* might affect device reliability. IDT does not recommend designing to the specifications given under “Absolute Maximum Ratings.”

**Important note:** The *operating conditions* given in section 2.2 set the conditions over which IDT specifies device operation. These are the conditions that the application circuit should provide to the device for it to function as intended. Unless otherwise noted, the limits for parameters that appear in the *operating conditions* section are used as test conditions for the limits given in the *electrical characteristics* (section 2.3), *operating conditions*, and *interface characteristics and nonvolatile memory* sections.

### 2.1. Absolute Maximum Ratings

**Table 2.1 Absolute Maximum Ratings**

No.	Parameter	Symbol	Conditions	Min	Max	Unit
2.1.1	Supply voltage	VDDE		-40	40	VDC
2.1.2	Voltage at AOUT pin	V <sub>AOUT</sub>		-40	40	VDC
2.1.3	Analog supply voltage	VDDA		-0.3	6.5	VDC
2.1.4	Digital supply voltage	VDD		-0.3	1.98	VDC
2.1.5	Voltage at all other pins	V <sub>PIN</sub>		-0.3	VDDA +0.3	V
2.1.6	Storage temperature	T <sub>STG</sub>		-55	160	°C

## 2.2. Operating Conditions

All voltages in this section are relative to VSSA.

**Table 2.2 Operating Conditions**

Note: See important notes at the end of the table.

No.	Parameter	Symbol	Conditions	Min	Typical	Max	Unit
2.2.1	Supply voltage	VDDE	To VSSE	4.5	5	5.5	V
		VDDA	To VSSA VDDE minus drop through protection switch	(VDDE – 0.1)		VDDE	V
2.2.2	Junction temperature	T <sub>TQE</sub>	Extended Temperature Range (TQE)	-40		150	°C
		T <sub>AMB_TQA</sub>	Advanced-Performance Temperature Range (TQA)	-40		125	°C
		T <sub>AMB_TQI</sub>	Best-Performance Temperature Range (TQI)	-25		85	°C
2.2.3	Bridge resistance <sup>1), 2)</sup>	R <sub>BR</sub>		2		10	kΩ
		R <sub>BR_10-90</sub>	Output range 10-90%	1		15	kΩ
1) No measurement in mass production; parameter is guaranteed by design and/or quality observation. 2) R <sub>BR</sub> greater than the maximum limit results in higher noise.							

### 2.3. Electrical Parameters

All parameter values in this section are valid under the operating conditions specified in section 2.2. All voltages referenced to VSSA.

Note: All parameters measured/validated for  $r_{ADC} = 14$ -bit; segmentation of 1<sup>st</sup> and 2<sup>nd</sup> ADC stage = 8/6;  $f_{OSC} = 8$ MHz; analog gain = ~100;  $T_{AMB\_TQE}$  (see specification 2.2.2).

**Table 2.3 Electrical Parameters**

Note: See important table notes at the end of the table (page 7).

No.	Parameter	Symbol	Conditions	Min	Typ	Max	Unit
<b>2.3.1. Supply Current and System Operation Conditions</b>							
2.3.1.1	Supply current <sup>1)</sup>	$I_S$	Oscillator adjusted (typical $f_{OSC} = 8$ MHz).		5.5	7	mA
2.3.1.2	Sensor bridge supply voltage	$V_{SENS}$	$V_{SENS} = V_{TOP} - V_{BOT}$ at $R_{BR} \geq 2k\Omega$	0.9		1	VDDA
2.3.1.3	Oscillator frequency <sup>2)</sup>	$f_{OSC}$		7.2	8	8.8	MHz
2.3.1.4	Oscillator frequency temperature coefficient	$TC_{OSC}$		-200		200	ppm/K
<b>2.3.2. Analog Front-End Characteristics</b>							
2.3.2.1	Input span	$V_{IN\_SPAN}$	Analog gain = 1 to 200	1		800	mV/V
2.3.2.2	Common mode input range	$V_{IN\_CM}$	Depends on gain adjustment	0.25		0.75	$V_{SENS}$
2.3.2.3	External capacitance at input	$C_{IN\_EXT}$	Capacitance at pins BR1P and BR1N to VSSA	0		12	nF
2.3.2.4	Input leakage current <sup>3)</sup>	$I_{IN\_leak}$		-15		15	nA
<b>2.3.3. Temperature Measurement</b>							
2.3.3.1	PTAT internal temperature sensitivity	$ST_{TSI}$	Raw values, without conditioning calculation Analog gain setting= 6	20			$LSB_{14}/K$
2.3.3.2	External temperature diode channel gain	$AT_{SE\_D}$		10			$LSB_{14}/mV$
2.3.3.3	External temperature diode bias current	$IT_{SE\_D}$		10	20	40	$\mu A$
2.3.3.4	External temperature diode input range <sup>3)</sup>	$VT_{SE\_D}$	Relative to $V_{TOP}$	-1		-0.2	V

No.	Parameter	Symbol	Conditions	Min	Typ	Max	Unit
2.3.3.5	External RTD channel gain	ATSE_RTD		10			LSB/mV
2.3.3.6	External RTD input range <sup>3)</sup>	V <sub>TSE_RTD</sub>	Relative to VDDA	-2		-0.2	V
<b>2.3.4. Sensor Diagnostics</b>							
2.3.4.1	Sensor connection loss threshold	R <sub>SCC_open</sub>		100			kΩ
2.3.4.2	Sensor short threshold to BOT or TOP pin	R <sub>SCC_SH_BT</sub>				50	Ω
2.3.4.3	Sensor short threshold between inputs	R <sub>SCC_SH_IN</sub>				150	Ω
<b>2.3.5. A2D Conversion</b>							
2.3.5.1	ADC resolution <sup>3)</sup>	r <sub>ADC</sub>	Selection: 12, 14, 16 or 18 bit	12		18	Bit
2.3.5.2	DNL <sup>3)</sup>	DNL <sub>ADC</sub>	Best fit; overall AFE; V <sub>ADC_IN</sub> according to 2.3.6.4.			0.95	LSB
2.3.5.3	INL TQA temperature range (specified in 2.2.2) <sup>3)</sup>	INL <sub>ADC_TQA</sub>	Best fit			4	LSB
2.3.5.4	INL TQE temperature range (specified in 2.2.2)	INL <sub>ADC_TQE</sub>	At 14-bit resolution			8	LSB
2.3.5.5	ADC input range	V <sub>ADC_IN</sub>		0.1		0.9	V <sub>SENS</sub>
<b>2.3.6. DAC and Analog Output (AOUT Pin)</b>							
2.3.6.1	DAC resolution	r <sub>DAC</sub>	Analog output		12		Bit
2.3.6.2	Output current sink/source	I <sub>OUT</sub>	V <sub>AOUT</sub> : 5-95%, R <sub>LOAD</sub> ≥ 5kΩ			2.5	mA
			V <sub>AOUT</sub> : 10-90%, R <sub>LOAD</sub> ≥ 1kΩ			5	mA
2.3.6.3	Short-circuit current (AOUT to VSSE or VDDE)	I <sub>OUT_max</sub>	Short to VSSE or VDDE	-25		25	mA
2.3.6.4	Addressable output range	V <sub>R_OUT</sub>		0.01		0.99	VDDE
2.3.6.5	Load capacitance	C <sub>LOAD</sub>	Defined for best EMC performance	4	10	150	nF
2.3.6.6	Output slew rate	SR <sub>OUT</sub>	C <sub>LOAD</sub> < 50nF	0.1			V/μs
2.3.6.7	Clipping levels	LowLim	Configurable 8-bit value stored in NVM	0		25	%VDDE
		UppLim	Configurable 8-bit value stored in NVM	75		100	%VDDE
2.3.6.8	Clipping adjustment step					0.1	%VDDE
2.3.6.9	Output resistance in Diagnostic Mode	R <sub>OUT_DIA</sub>	Diagnostic Range: 4% to 96%, R <sub>LOAD</sub> ≥ 5kΩ 8% to 92%, R <sub>LOAD</sub> ≥ 1kΩ			80	Ω

No.	Parameter	Symbol	Conditions	Min	Typ	Max	Unit
2.3.6.10	DNL	DNL <sub>OUT</sub>	r <sub>DAC</sub> =12 bit	-1.5		1.5	LSB
2.3.6.11	INL TQA temperature range (specified in 2.2.2) <sup>3)</sup>	INL <sub>OUT</sub>	Best fit, r <sub>DAC</sub> =12-Bit	-5		5	LSB
2.3.6.12	INL TQE temperature range (specified in 2.2.2)	INL <sub>OUT</sub>	Best fit, r <sub>DAC</sub> =12-Bit	-8		8	LSB
2.3.6.13	Output leakage current at 125°C	I <sub>LEAK_OUT</sub>	In the event of power or ground loss	-12		12	μA
2.3.6.14	Output leakage current at 150°C	I <sub>LEAK_OUT</sub>	In the event of power or ground loss	-20		20	μA
<b>2.3.7. System Response</b>							
2.3.7.1	Startup time <sup>3), 4)</sup> (time to first valid output after power-on)	t <sub>STARTUP</sub>	f <sub>OSC</sub> = 8MHz; ADC: 14-bit and 2 <sup>nd</sup> order conversion			5	ms
2.3.7.2	Response time <sup>3) 4) 5)</sup>	t <sub>RESPONSE</sub>	100% input step, excluding transmission time			1.1	ms
2.3.7.3	Bandwidth <sup>3)</sup>		In comparison to analog signal conditioners; 66% jump		1		kHz
2.3.7.4	Analog output noise peak-to-peak <sup>3)</sup>	V <sub>NOISE,PP</sub>	DAC and output buffer only; bandwidth ≤ 10kHz			10	mV
2.3.7.5	Analog output noise RMS <sup>3)</sup>	V <sub>NOISE,RMS</sub>	DAC and output buffer only; bandwidth ≤ 10kHz			3	mV
2.3.7.6	Ratiometricity error <sup>3)</sup>	RE <sub>OUT_5</sub>	Maximum error of VDDE range = 4.5V to 5.5V	-1000		1000	ppm
2.3.7.7	Overall error <sup>6)</sup>	F <sub>ALL</sub>	TQA temperature range (specified in 2.2.2)		0.35		% FSO
			TQE temperature range (specified in 2.2.2)		0.5		
1) Excluding bridge supply current and excluding output current at AOUT pin. 2) Oscillator frequency can be trimmed via a setting in nonvolatile memory (NVM). 3) No measurement in mass production; parameter is guaranteed by design and/or quality observation. 4) No bridge settling included in timing. 5) Dependent on the configuration. The specified limit is valid only for ADC resolutions ≤15 bits. 6) FSO: full-scale output. No sensor-caused effects included in overall error. ADC input range from 10% to 90% of V <sub>SENS</sub> ; DAC from 5% to 95% of output range.							

## 2.4. Interface Characteristics and Nonvolatile Memory

**Table 2.4 Interface Characteristics and Nonvolatile Memory**

Note: See important table notes at the end of the table.

No.	Parameter	Symbol	Conditions	Min	Typ	Max	Unit
<b>2.4.1. I<sup>2</sup>C™ Interface</b>							
2.4.1.1	I <sup>2</sup> C™ voltage level HIGH <sup>1)</sup>	V <sub>I2C_HIGH</sub>		0.5			VDDA
2.4.1.2	I <sup>2</sup> C™ voltage level LOW <sup>1)</sup>	V <sub>I2C_LOW</sub>				0.2	VDDA
2.4.1.3	Slave output level LOW <sup>1)</sup>	V <sub>I2C_LOW_OUT</sub>	Open drain, I <sub>OL</sub> < 4mA			0.1	VDDA
2.4.1.4	SDA load capacitance <sup>1)</sup>	C <sub>I2C_SDA</sub>				400	pF
2.4.1.5	SCL clock frequency <sup>1)</sup>	f <sub>I2C</sub>				400	kHz
2.4.1.6	Internal pull-up resistor <sup>1)</sup>	R <sub>I2C_PULLUP</sub>		25		100	kΩ
<b>2.4.2. ZACwire™ One-Wire Interface (OWI at AOUT pin)</b>							
2.4.2.1	OWI voltage level HIGH <sup>1)</sup>	V <sub>OWI_IN_H</sub>	Master to slave	0.75			VDDE
2.4.2.2	OWI voltage level LOW <sup>1)</sup>	V <sub>OWI_IN_L</sub>	Master to slave			0.2	VDDE
2.4.2.3	Slave output level LOW <sup>1)</sup>	V <sub>OWI_OUT_L</sub>	Open drain, I <sub>OL</sub> ≤ 2mA			0.1	VDDE
2.4.2.4	Start window <sup>1)</sup>	t <sub>OWI_STARTWIN</sub>		100		300	ms
2.4.2.5	Bus free time	t <sub>OWI_IDLE</sub>	Between stop and next start	25			μs
2.4.2.6	Hold time start condition	t <sub>OWI_START</sub>	Valid minimum f <sub>clk</sub>	25			μs
2.4.2.7	Bit time	t <sub>OWI_BIT</sub>	Maximum range	20		8000	μs
			Typical operating range	40		4000	μs
2.4.2.8	Duty ratio bit '0'	t <sub>OWI_0</sub>		0.125	0.25	0.375	t <sub>OWI_BIT</sub>
2.4.2.9	Duty ratio bit '1'	t <sub>OWI_1</sub>		0.625	0.75	0.875	t <sub>OWI_BIT</sub>
2.4.2.10	Hold time stop condition	t <sub>OWI_STOP</sub>	t <sub>OWI_BIT_L</sub> is the bit time of the last valid bit	2			t <sub>OWI_BIT_L</sub>
2.4.2.11	Bit period deviation	t <sub>OWI_BIT_DEV</sub>		0.55	1.0	1.5	t <sub>OWI_BIT</sub>



No.	Parameter	Symbol	Conditions	Min	Typ	Max	Unit
<b>2.4.3. Nonvolatile Memory (NVM)</b>							
2.4.3.1	Junction temperature for NVM programming <sup>2)</sup>	T <sub>AMB_NVM</sub>		-40		150	°C
2.4.3.2	Re-write cycles <sup>1)</sup>	N <sub>NVM_TQA</sub>	For T <sub>TQA</sub> (see range in specification 2.2.2)	100			
2.4.3.3	Re-write cycles at 150°C	N <sub>NVM_TQE</sub>	For T <sub>TQE</sub> (see range in specification 2.2.2)	10			
2.4.3.4	Data retention <sup>1)</sup>	t <sub>NVM_RET</sub>	Temperature profile: 22h bake at 250°C	15			Year
2.4.3.5	Programming time <sup>1)</sup>	t <sub>NVM_WRI</sub>	Per written word		2.2	5	ms
<p>1) No measurement in mass production; parameter is guaranteed by design and/or quality observation.</p> <p>2) Valid for dice. Note: Additional package and temperature range cause restrictions.</p>							

### 3 ESD Protection and EMC Specification

#### 3.1. ESD Protection

All pins have an ESD protection of  $\geq 2000V$  according to the Human Body Model (HBM, based on MIL883, Method 3015.7). The VDDE, VSSE, and AOUT pins have an additional ESD protection of  $\geq 4000V$  (HBM).

In addition, Charged Device Model (CDM) tests are processed with protection levels of  $\geq 750V$  for corner pins and  $\geq 500V$  for all other pins.

The level of ESD protection has been tested with devices in QFN24 4X4mm packages during the product qualification.

#### 3.2. Latch-Up Immunity

All pins pass  $\pm 100mA$  latch-up test based on testing that conforms to the standard EIA/JESD 78.

#### 3.3. Electromagnetic Emission

The wired emission of externally connected pins of the device is measured according to the following standard: *IEC 61967\_4:2002 + A1:2006*.

Measurements must be performed with the application circuits described in the *ZSSC4151 Application Description*.

For the off-board pins, the spectral power measured with the  $150\Omega$  method must not exceed the limits according to *IEC 61967\_4k, Annex B.4 code H10kN*. For the VSSE pin, the spectral power measured with the  $1\Omega$  method must not exceed the limits according to *IEC 61967\_4k, Annex B.4 code 15KmO*.

#### 3.4. Conducted Susceptibility (DPI)

The conducted susceptibility of externally connected pins of the device is measured according to the IEC 62132-4 standard, which describes the direct power injection (DPI) test method.

Measurements must be performed with the application circuit described in the *ZSSC4151 Application Description*.

Measurements are performed with an internal reference capacitor and internal temperature sensor. The sensing element is replaced by a resistive divider. Calibration is parameterized so that  $\sim 50\%$  VDDA is output.

Table 3.1 gives the specifications for the DPI tests. RES refers to the coupling impedance.

**Table 3.1 Conducted Susceptibility (DPI) Tests**

Test	Frequency Range	Target (dBm)	Load Pins	Protocol	Error Band	Comment
DPI, direct coupled	1MHz to 300MHz	26	VDDE, AOUT	Analog out	$\pm 1\%$	LOAD RES = $5k\Omega$ LOAD CAP = $10nF$
DPI, direct coupled	300MHz to 1000MHz	32	VDDE, AOUT	Analog out	$\pm 1\%$	LOAD RES = $5k\Omega$ LOAD CAP = $10nF$

## 4 Reliability and RoHS Conformity

The ZSSC4151 is qualified according to the AEC-Q100 standard, operating temperature grade 0. The qualification is extended to 3000h for the High Temperature Operating Life (HTOL) Test for one lot. Two manufacturing lots of extended HTOL qualification data (minimum of 3000h test time) for the ZSSC4151 or other products using identical technology (metallization), the same package supplier, the same package style, and the same die size within a specific tolerance are used to prove the package and bond reliability in the range of 3000h HTOL.

A FIT rate  $\leq 10$  FIT (temperature = 55°C, confidence level = 60%) is guaranteed. A typical FIT rate of TSMC's CV018BCD technology, which is used for the ZSSC4151, is 1 FIT.

The ZSSC4151 complies with the RoHS directive and does not contain hazardous substances.

## 5 Glossary

Term	Description
ADC	Analog-to-Digital Converter
AEC	Automotive Electronics Council
AFE	Analog Front-End
BAMP	Buffer Amplifier
BR	Bridge Sensor
CDM	Charged Device Model
CM	Command Mode
CMC	Calibration Microcontroller
DAC	Digital-to-Analog Converter
DNL	Differential Nonlinearity
DPI	Direct Power Injection
EMC	Electromagnetic Compatibility
ESD	Electrostatic Discharge
FIT	Failures in Time
FSO	Full Scale Output
HBM	Human Body Model
HTOL	High Temperature Operating Life
I <sup>2</sup> C™	Inter-Integrated Circuit—serial two-wire data bus, trademark of NXP
INL	Integral Nonlinearity
LSB	Least Significant Bit
MUX	Multiplexer
NVM	Nonvolatile Memory

Term	Description
OWI	One-Wire Interface
PGA	Programmable Gain Amplifier
PTAT	Proportional-to-Absolute Temperature
PTC	Thermistor – Positive Temperature Coefficient Resistor
PWR	Power Management and Protection Unit
QFN	Quad-Flat No-Leads – IC package
RAM	Random Access Memory
RISC	Reduced Instruction Set Computing
ROM	Read-Only Memory
RMS	Root-Mean-Square
RTD	Resistance Temperature Device
SCCM	Sensor Check and Common Mode Adjustment Unit
SCL	Serial Clock
SDA	Serial Data
SSC	Sensor Short Check (diagnostic feature) or Sensor Signal Conditioner
TQA, TQE, TQI	Temperature range identifier. See specification 2.2.2 for definition.
ZACwire™	IDT-specific One-Wire Interface

## 6 Document Revision History

Revision	Date	Description
1.00	September 13, 2015	First release.
1.01	November 10, 2015	Extended leakage current description in section 2.3.6 for specifications 2.3.6.13 and 2.3.6.14 Updates for table notes for Table 2.3. Revision of pin names BRP to BR1P and BRN to BR1N.
1.02	April 12, 2016	Added minimum value for ratiometricity error in Table 2.3. Updated section 4 regarding completion of AEC-Q100 qualification and extension of the minimum test time to 3000h. Updated specification 2.3.7.7 for improved accuracy of $\pm 0.35\%$ of FSO at $-40^{\circ}\text{C}$ to $125^{\circ}\text{C}$ and $0.5\%$ FSO at $-40^{\circ}\text{C}$ to $150^{\circ}\text{C}$ .
	April 20, 2016	Changed to IDT branding.



## Notice

1. Descriptions of circuits, software and other related information in this document are provided only to illustrate the operation of semiconductor products and application examples. You are fully responsible for the incorporation or any other use of the circuits, software, and information in the design of your product or system. Renesas Electronics disclaims any and all liability for any losses and damages incurred by you or third parties arising from the use of these circuits, software, or information.
2. Renesas Electronics hereby expressly disclaims any warranties against and liability for infringement or any other claims involving patents, copyrights, or other intellectual property rights of third parties, by or arising from the use of Renesas Electronics products or technical information described in this document, including but not limited to, the product data, drawings, charts, programs, algorithms, and application examples.
3. No license, express, implied or otherwise, is granted hereby under any patents, copyrights or other intellectual property rights of Renesas Electronics or others.
4. You shall be responsible for determining what licenses are required from any third parties, and obtaining such licenses for the lawful import, export, manufacture, sales, utilization, distribution or other disposal of any products incorporating Renesas Electronics products, if required.
5. You shall not alter, modify, copy, or reverse engineer any Renesas Electronics product, whether in whole or in part. Renesas Electronics disclaims any and all liability for any losses or damages incurred by you or third parties arising from such alteration, modification, copying or reverse engineering.
6. Renesas Electronics products are classified according to the following two quality grades: "Standard" and "High Quality". The intended applications for each Renesas Electronics product depends on the product's quality grade, as indicated below.

"Standard": Computers; office equipment; communications equipment; test and measurement equipment; audio and visual equipment; home electronic appliances; machine tools; personal electronic equipment; industrial robots; etc.

"High Quality": Transportation equipment (automobiles, trains, ships, etc.); traffic control (traffic lights); large-scale communication equipment; key financial terminal systems; safety control equipment; etc.

Unless expressly designated as a high reliability product or a product for harsh environments in a Renesas Electronics data sheet or other Renesas Electronics document, Renesas Electronics products are not intended or authorized for use in products or systems that may pose a direct threat to human life or bodily injury (artificial life support devices or systems; surgical implantations; etc.), or may cause serious property damage (space system; undersea repeaters; nuclear power control systems; aircraft control systems; key plant systems; military equipment; etc.). Renesas Electronics disclaims any and all liability for any damages or losses incurred by you or any third parties arising from the use of any Renesas Electronics product that is inconsistent with any Renesas Electronics data sheet, user's manual or other Renesas Electronics document.

7. No semiconductor product is absolutely secure. Notwithstanding any security measures or features that may be implemented in Renesas Electronics hardware or software products, Renesas Electronics shall have absolutely no liability arising out of any vulnerability or security breach, including but not limited to any unauthorized access to or use of a Renesas Electronics product or a system that uses a Renesas Electronics product. RENESAS ELECTRONICS DOES NOT WARRANT OR GUARANTEE THAT RENESAS ELECTRONICS PRODUCTS, OR ANY SYSTEMS CREATED USING RENESAS ELECTRONICS PRODUCTS WILL BE INVULNERABLE OR FREE FROM CORRUPTION, ATTACK, VIRUSES, INTERFERENCE, HACKING, DATA LOSS OR THEFT, OR OTHER SECURITY INTRUSION ("Vulnerability Issues"). RENESAS ELECTRONICS DISCLAIMS ANY AND ALL RESPONSIBILITY OR LIABILITY ARISING FROM OR RELATED TO ANY VULNERABILITY ISSUES. FURTHERMORE, TO THE EXTENT PERMITTED BY APPLICABLE LAW, RENESAS ELECTRONICS DISCLAIMS ANY AND ALL WARRANTIES, EXPRESS OR IMPLIED, WITH RESPECT TO THIS DOCUMENT AND ANY RELATED OR ACCOMPANYING SOFTWARE OR HARDWARE, INCLUDING BUT NOT LIMITED TO THE IMPLIED WARRANTIES OF MERCHANTABILITY, OR FITNESS FOR A PARTICULAR PURPOSE.
8. When using Renesas Electronics products, refer to the latest product information (data sheets, user's manuals, application notes, "General Notes for Handling and Using Semiconductor Devices" in the reliability handbook, etc.), and ensure that usage conditions are within the ranges specified by Renesas Electronics with respect to maximum ratings, operating power supply voltage range, heat dissipation characteristics, installation, etc. Renesas Electronics disclaims any and all liability for any malfunctions, failure or accident arising out of the use of Renesas Electronics products outside of such specified ranges.

9. Although Renesas Electronics endeavors to improve the quality and reliability of Renesas Electronics products, semiconductor products have specific characteristics, such as the occurrence of failure at a certain rate and malfunctions under certain use conditions. Unless designated as a high reliability product or a product for harsh environments in a Renesas Electronics data sheet or other Renesas Electronics document, Renesas Electronics products are not subject to radiation resistance design. You are responsible for implementing safety measures to guard against the possibility of bodily injury, injury or damage caused by fire, and/or danger to the public in the event of a failure or malfunction of Renesas Electronics products, such as safety design for hardware and software, including but not limited to redundancy, fire control and malfunction prevention, appropriate treatment for aging degradation or any other appropriate measures. Because the evaluation of microcomputer software alone is very difficult and impractical, you are responsible for evaluating the safety of the final products or systems manufactured by you.
10. Please contact a Renesas Electronics sales office for details as to environmental matters such as the environmental compatibility of each Renesas Electronics product. You are responsible for carefully and sufficiently investigating applicable laws and regulations that regulate the inclusion or use of controlled substances, including without limitation, the EU RoHS Directive, and using Renesas Electronics products in compliance with all these applicable laws and regulations. Renesas Electronics disclaims any and all liability for damages or losses occurring as a result of your noncompliance with applicable laws and regulations.
11. Renesas Electronics products and technologies shall not be used for or incorporated into any products or systems whose manufacture, use, or sale is prohibited under any applicable domestic or foreign laws or regulations. You shall comply with any applicable export control laws and regulations promulgated and administered by the governments of any countries asserting jurisdiction over the parties or transactions.
12. It is the responsibility of the buyer or distributor of Renesas Electronics products, or any other party who distributes, disposes of, or otherwise sells or transfers the product to a third party, to notify such third party in advance of the contents and conditions set forth in this document.
13. This document shall not be reprinted, reproduced or duplicated in any form, in whole or in part, without prior written consent of Renesas Electronics.
14. Please contact a Renesas Electronics sales office if you have any questions regarding the information contained in this document or Renesas Electronics products.  
(Note 1) "Renesas Electronics" as used in this document means Renesas Electronics Corporation and also includes its directly or indirectly controlled subsidiaries.  
(Note 2) "Renesas Electronics product(s)" means any product developed or manufactured by or for Renesas Electronics.

(Rev. 4.0-2 April 2020)

## Corporate Headquarters

TOYOSU FORESIA, 3-2-24 Toyosu,  
Koto-ku, Tokyo 135-0061, Japan  
[www.renesas.com](http://www.renesas.com)

## Contact Information

For further information on a product, technology, the most up-to-date version of a document, or your nearest sales office, please visit:  
[www.renesas.com/contact/](http://www.renesas.com/contact/)

## Trademarks

Renesas and the Renesas logo are trademarks of Renesas Electronics Corporation. All trademarks and registered trademarks are the property of their respective owners.

单击下面可查看定价，库存，交付和生命周期等信息

[>>Renesas\(瑞萨\)](#)