

6A, 24V, 600kHz Step-Down Converter with Synchronous Gate Driver

Purpose

The RT8298A is a current mode step-down converter with the input voltage range from 4.5V to 24V and provides 6A output current. This document explains the function and use of the RT8298A evaluation board (EVB), and provides information to enable operation, modification of the evaluation board and circuit to suit individual requirements.

Table of Contents

Purpose	1
Introduction.....	2
Key Performance Summary Table	2
Bench Test Setup Conditions	3
Schematic, Bill of Materials & Board Layout	5
More Information.....	8
Important Notice for Richtek Evaluation Board	8

Introduction

General Product Information

The RT8298A is a synchronous step-down DC/DC converter with an integrated high side internal power MOSFET and a gate driver for a low side external power MOSFET. It can deliver up to 6A output current from a 4.5V to 24V input supply. The RT8298A's current mode architecture allows the transient response to be optimized over a wider input voltage and load range. Cycle-by-cycle current limit provides protection against shorted outputs and soft-start eliminates input current surge during start-up. The RT8298A is synchronizable to an external clock with frequency ranging from 300kHz to 1.5MHz.

Product Feature

- 4.5V to 24V Input Voltage Range
- 6A Output Current
- 45mΩ Internal High Side N-MOSFET
- Current Mode Control
- 600kHz Switching Frequency
- Adjustable Output from 0.8V to 15V
- Up to 95% Efficiency
- Internal Compensation
- Stable with Ceramic Capacitors
- Synchronous External Clock : 300kHz to 1.5MHz
- Cycle-by-Cycle Current Limit
- Input Under Voltage Lockout
- Output Under Voltage Protection
- Power Good Indicator
- Thermal Shutdown Protection
- Force PWM Turn On
- RoHS Compliant and Halogen Free

Key Performance Summary Table

Key Features	Evaluation Board Number : PCB026_V1
Default Input Voltage	12V
Max Output Current	6A
Default Output Voltage	3.3V
Default Marking & Package Type	RT8298AGSP, SOP-8 (Exposed Pad)

Bench Test Setup Conditions

Headers Description and Placement

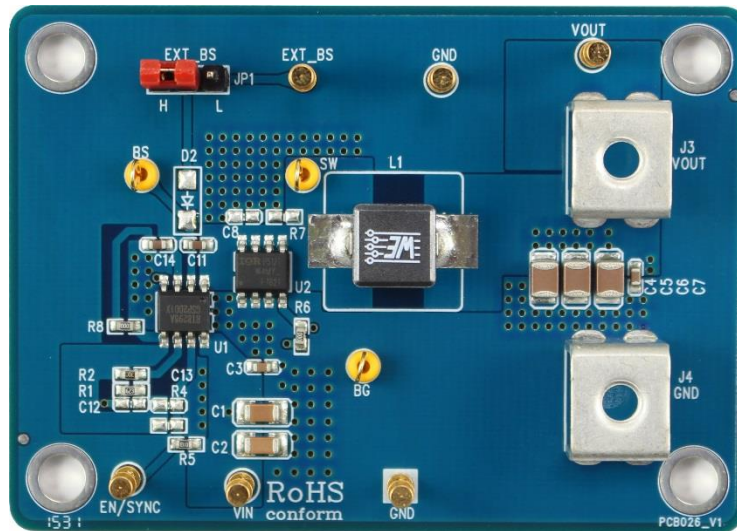

Please carefully inspect the EVB IC and external components, comparing them to the following Bill of Materials, to ensure that all components are installed and undamaged. If any components are missing or damaged during transportation, please contact the distributor or send e-mail to evb_service@richtek.com

Test Points

The EVB is provided with the test points and pin names listed in the table below.

Test point/ Pin name	Signal	Comment (expected waveforms or voltage levels on test points)
VIN	Input voltage	Power Input. The available input voltage range is from 4.5V to 24V. A 22 μ F or larger input capacitor is needed to reduce voltage spikes at the input.
EN/SYNC	Enable test point	Enable or External Frequency Synchronization Input. A logic-high (2V < EN < 5.5V) enables the converter; a logic-low forces the IC into shutdown mode reducing the supply current to less than 3 μ A. For external frequency synchronization operation, the available frequency range is from 300kHz to 1.5MHz.
GND	Ground	Ground. The exposed pad must be soldered to a large PCB and connected to GND for maximum thermal dissipation.
VCC	Internal regulator output	BG Driver Bias Supply. Decouple with a 1 μ F X5R/X7R ceramic capacitor between the VCC pin and GND.
BOOT	Bootstrap supply test point	Bootstrap supply for high-side gate driver. Connect a 0.1 μ F capacitor between BOOT and SW to power the internal gate driver.
SW	Switch node test point	Switching Node. Output of the internal high side MOSFET. Connect this pin to external low-side N-MOSFET, inductor and bootstrap capacitor.
BG	Internal regulator	Gate Driver Output. Connect this pin to the gate of the external low-side N-MOSFET.
FB	Feedback test point	Feedback Input. This pin is connected to the converter output. It is used to set the output of the converter to regulate to the desired value via an external resistive divider. The feedback reference voltage is 0.808V typically.

Power-up & Measurement Procedure

1. Apply a 12V nominal input power supply ($4.5V < V_{IN} < 24V$) to the VIN and GND terminals.
2. Verify the output voltage (approximately 3.3V) between VOUT and GND.
3. Connect an external load up to 6A to the VOUT and GND terminals and verify the output voltage and current.

Output Voltage Setting

Set the output voltage with the resistive divider (R2, R3) between VOUT and GND with the midpoint connected to FB. The output is set by the following formula :

$$V_{OUT} = 0.808 \times \left(1 + \frac{R2}{R3}\right)$$

Schematic, Bill of Materials & Board Layout

EVB Schematic Diagram

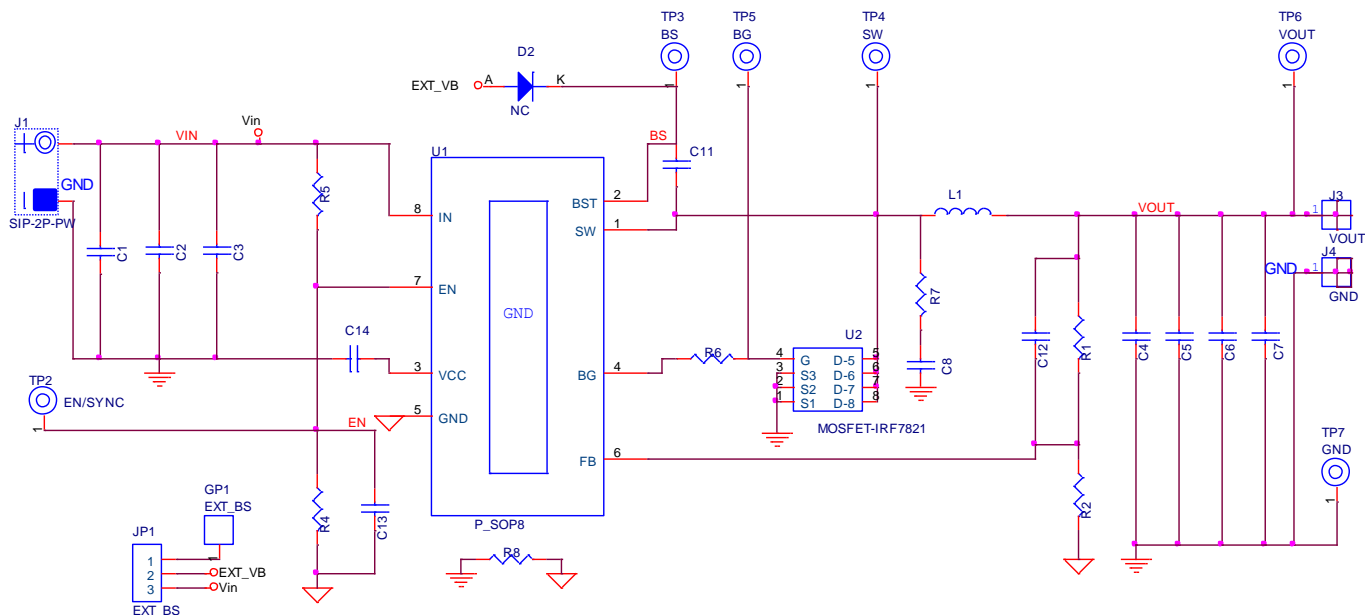

Bill of Materials

Reference	Qty	Part Number	Description	Package	Manufacture
U1	1	RT8298AGSP	DC/DC Converter	SOP-8 (Exposed Pad)	RICHTEK
C1, C2	2	GRM31CR71E106KA12L	10 μ F/25V/X7R	C-1206	MURATA
C3, C7	2	C1608X7R1H104KT000N	0.1 μ F/50V/X7R	C-0603	TDK
C4, C5, C6	3	C3225X5R1E226MT	22 μ F/25V/X5R	C-1210	TDK
R4, D2, C13, R7, C8, C12	6		N/A		
C14, C11	2	C1608X5R1E105KT000E	1 μ F/25V/X5R	C-0603	TDK
R5	1		100k	R-0603	
R6, R8	2		0	R-0603	
R1	1		62k	R-0603	
R2	1	NR8040T1R4N	20k	R-0603	
L1	1	7443340220	2.2 μ F/16.5A	8.4 x 7.9 mm	WE
U2	1	IRF7821	30V/13.6A	R-0603	FUTURE ELECTRONICS INC.

PCB Layout

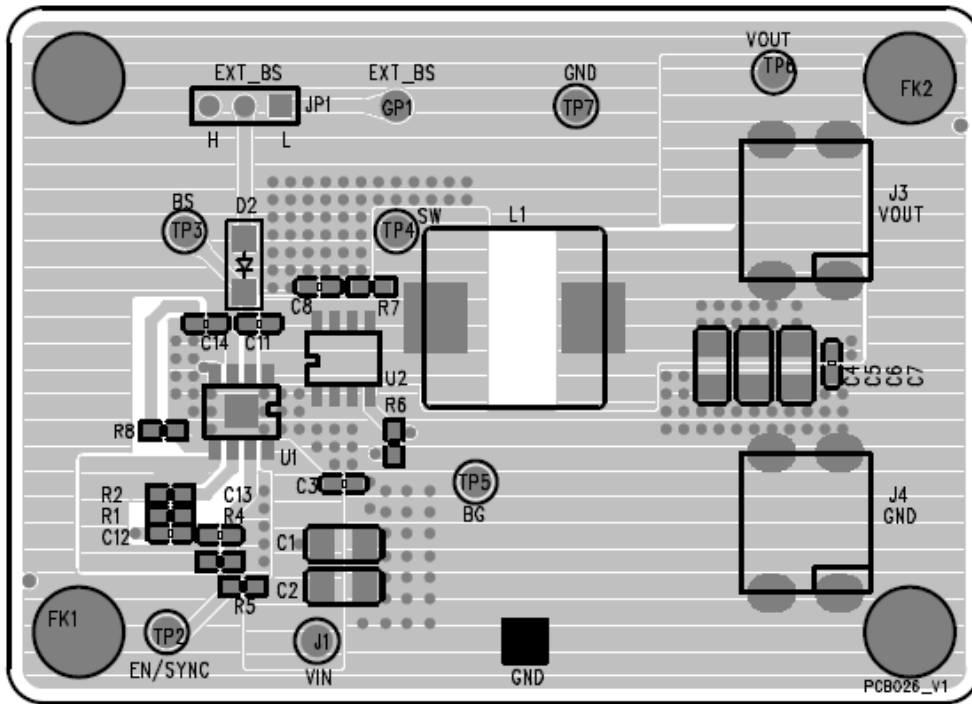

Top View (1st layer)

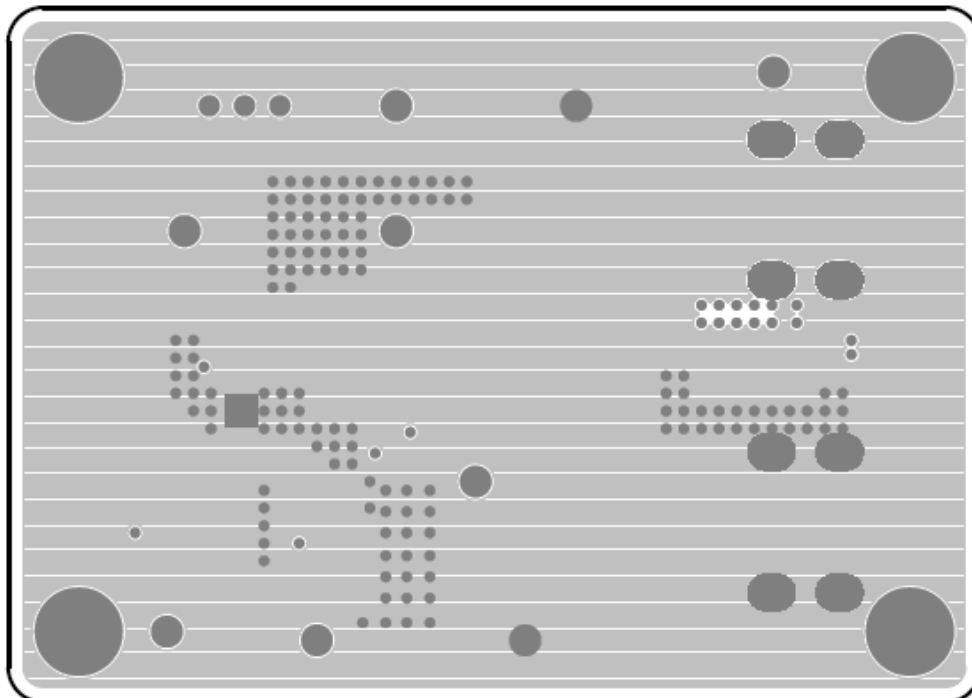

PCB Layout—Inner Side (2nd Layer)

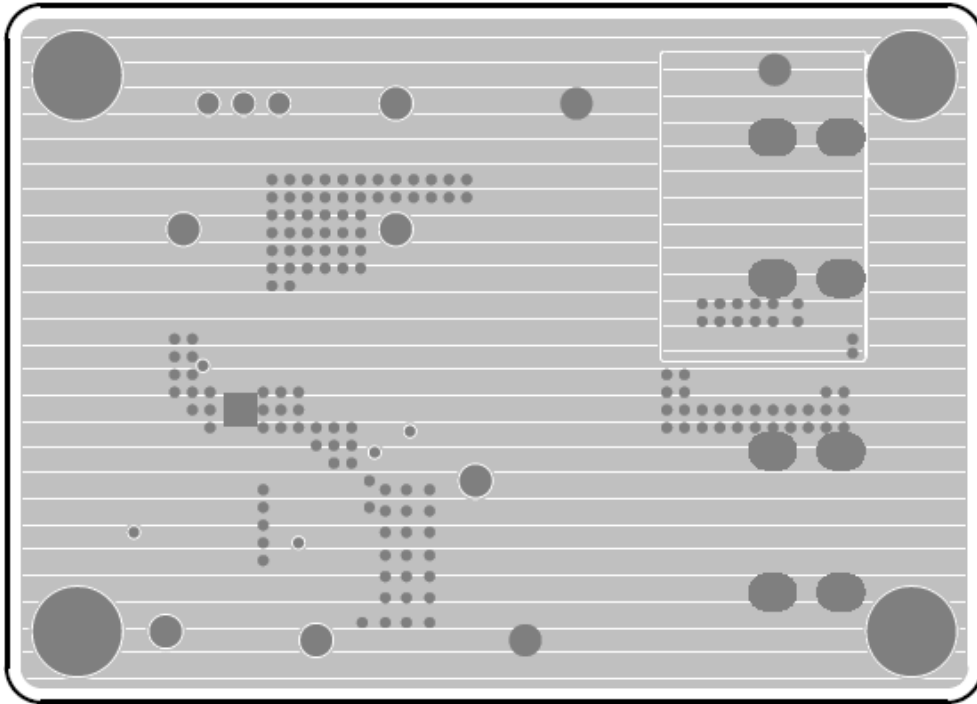

PCB Layout—Inner Side (3rd Layer)

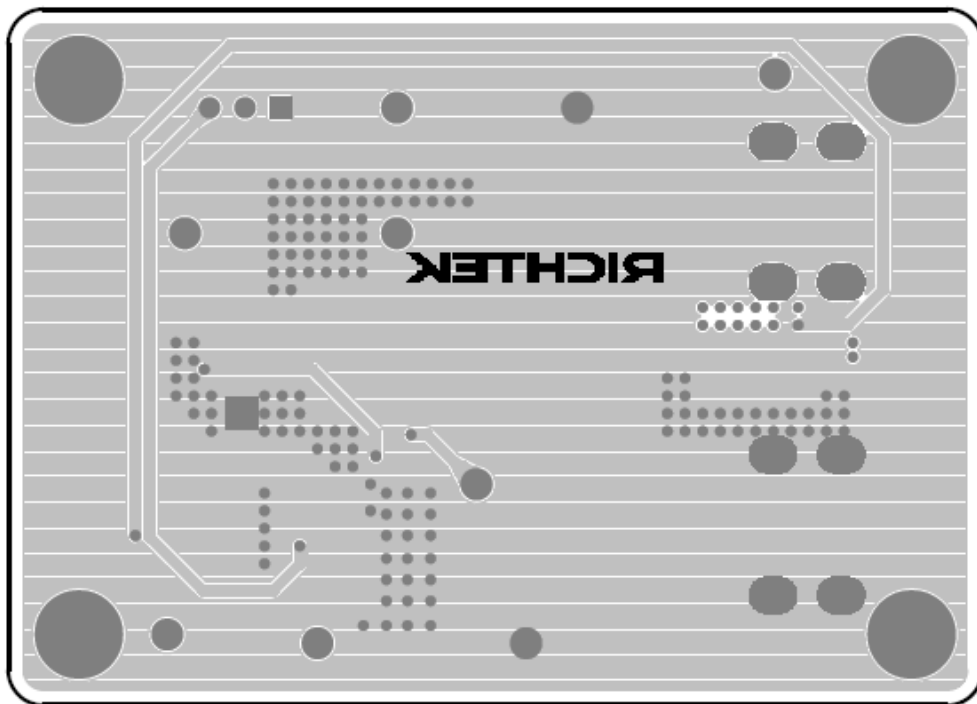

Bottom View (4th Layer)

More Information

For more information, please find the related datasheet or application notes from Richtek website <http://www.richtek.com>.

Important Notice for Richtek Evaluation Board

THIS DOCUMENT IS FOR REFERENCE ONLY, NOTHING CONTAINED IN THIS DOCUMENT SHALL BE CONSTRUED AS RICHTEK'S WARRANTY, EXPRESS OR IMPLIED, UNDER CONTRACT, TORT OR STATUTORY, WITH RESPECT TO THE PRESENTATION HEREIN. IN NO EVENT SHALL RICHTEK BE LIABLE TO BUYER OR USER FOR ANY AND ALL DAMAGES INCLUDING WITHOUT LIMITATION TO DIRECT, INDIRECT, SPECIAL, PUNITIVE OR CONSEQUENTIAL DAMAGES.

单击下面可查看定价，库存，交付和生命周期等信息

[>>Richtek\(台湾立锜\)](#)