

Tiny Package, High Performance, Regulated Charge Pump

General Description

The RT9361A/B is a high performance charge pump DC/DC converter that produces a regulated 4.5V and 5V output. No external inductor is required for operation. The operating voltage range is 2.8V to V_{OUT} . Internal soft-start circuitry effectively reduces the in-rush current both while start-up and mode change.

The RT9361A/B features very low quiescent current, over current protection and short circuit protection.

The RT9361A/B is available in WDFN-6L 2x2, SOT-23-6 and TSOT-23-6 package.

Ordering Information

RT9361A/B	□ □
	Package Type
	E : SOT-23-6
	J6 : TSOT-23-6
	QW : WDFN-6L 2x2 (W-Type)
	Lead Plating System
	P : Pb Free
	G : Green (Halogen Free and Pb Free)
	Output Voltage
	A : 5V
	B : 4.5V

Note :

Richtek products are :

- ▶ RoHS compliant and compatible with the current requirements of IPC/JEDEC J-STD-020.
- ▶ Suitable for use in SnPb or Pb-free soldering processes.

Features

- Input Voltage Range : 2.8V to V_{OUT}
- Internal Soft Start Function
- 5V/4.5V Fixed Output Voltage
- Over Current Protection Function
- Short Circuit Protection Function
- RoHS Compliant and 100% Lead (Pb)-Free

Applications

- Mobile phone, Smart Phone LED Backlight
- Camera Flash White LED
- LCD Display Supply

Pin Configurations

(TOP VIEW)

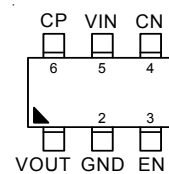

SOT-23-6/TSOT-23-6

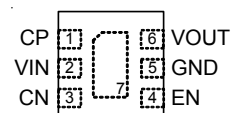

WDFN-6L 2x2

Marking Information

RT9361AGJ6

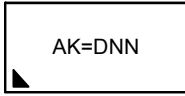

AK= : Product Code
DNN : Date Code

RT9361APJ6

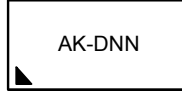

AK- : Product Code
DNN : Date Code

RT9361AGE

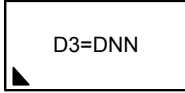

D3= : Product Code
DNN : Date Code

RT9361APE

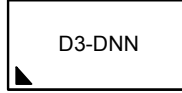

D3- : Product Code
DNN : Date Code

RT9361AGQW

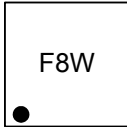

F8 : Product Code
W : Date Code

RT9361BPJ6

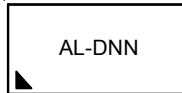

AL- : Product Code
DNN : Date Code

RT9361BGE

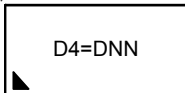

D4= : Product Code
DNN : Date Code

RT9361BPE

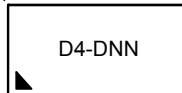

D4- : Product Code
DNN : Date Code

Typical Application Circuit

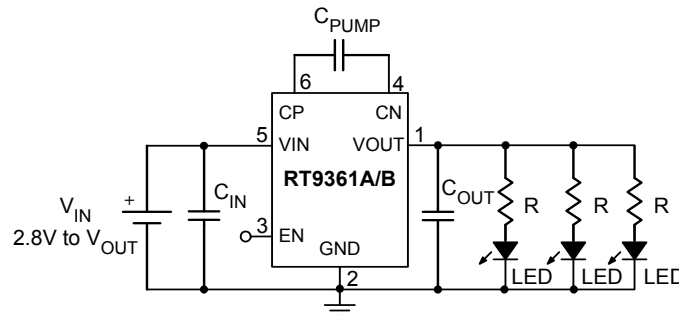

Part No.	Application Configuration	C _{IN} (μF)	C _{PUMP} (μF)	C _{OUT} (μF)
RT9361A	I _{OUT} < 60mA @ V _{IN} > 3.2V,	1 or 2.2	0.22	1 or 2.2
	I _{OUT} < 110mA @ V _{IN} > 3.2V,	10	1	10
RT9361B	I _{OUT} < 80mA @ V _{IN} > 3.2V,	1 or 2.2	0.22	1 or 2.2
	I _{OUT} < 150mA @ V _{IN} > 3.2V,	10	1	10

Functional Pin Description

Pin Number		Pin Name	Pin Function
T/SOT-23-6	WDFN-6L 2x2		
1	6	VOUT	Output Voltage
2	5, Exposed Pad (7)	GND	Ground. The exposed pad must be soldered to a large PCB and connected to GND for maximum power dissipation.
3	4	EN	Chip Enable (Active High)
4	3	CN	Flying Capacitor Negative Terminal
5	2	VIN	Power Input Voltage
6	1	CP	Flying Capacitor Positive Terminal

Function Block Diagram

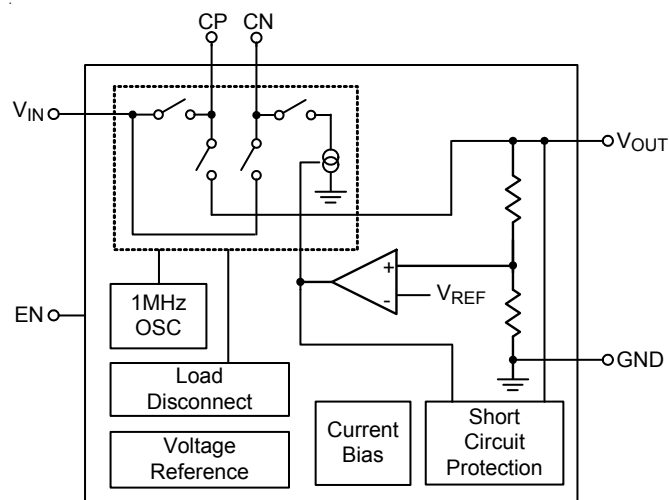

Absolute Maximum Ratings (Note 1)

• Supply Input Voltage	-----	-0.3V to 6V
• Other I/O Pin Voltages	-----	-0.3V to 6V
• Power Dissipation, P_D @ $T_A = 25^\circ\text{C}$		
T/SOT-23-6	-----	0.4W
WDFN-6L 2x2	-----	0.606W
• Package Thermal Resistance (Note 2)		
T/SOT-23-6, θ_{JA}	-----	250°C/W
WDFN-6L 2x2, θ_{JA}	-----	165°C/W
• Junction Temperature	-----	150°C
• Lead Temperature (Soldering, 10 sec.)	-----	260°C
• Storage Temperature Range	-----	-65°C to 150°C
• ESD Susceptibility (Note 3)		
HBM (Human Body Mode)	-----	2kV
MM (Machine Mode)	-----	200V

Recommended Operating Conditions (Note 4)

• Ambient Temperature Range	-----	-40°C to 85°C
• Junction Temperature Range	-----	-40°C to 125°C

Electrical Characteristics

($V_{IN} = 3.7V$, $T_A = 25^\circ\text{C}$, unless otherwise specified)

Parameter	Symbol	Test Conditions	Min	Typ	Max	Unit
Operation Voltage Range	V_{IN}	$V_{OUT} = 5V$	2.8	--	V_{OUT}	V
Output Voltage	V_{OUT}	RT9361A, $V_{IN} = 3.17V$ to $3.43V$, $I_{OUT} \leq 55mA$	4.83	5	5.2	V
		RT9361A, $V_{IN} > 3.2V$, $I_{OUT} < 110mA$	4.8	5	5.2	V
		RT9361B, $V_{IN} > 3.2V$, $I_{OUT} < 150mA$	4.32	4.5	4.68	V
Quiescent Current	I_Q	$I_{OUT} = 0$	--	2	4	mA
Maximum Output Current	I_{OUT}	RT9361A, $V_{IN} > 3.2V$, $C_{PUMP} = 1\mu F$	110	--	--	mA
		RT9361B, $V_{IN} > 3.2V$, $C_{PUMP} = 1\mu F$	150	--	--	
OCP	I_{OCP}		250	350	500	mA
Short Circuit Current			--	60	90	mA
Output Ripple		$I_{OUT} = 60mA$, $C_{OUT} = 2.2\mu F$	--	30	--	mV
Shut Down Current	I_{SHDN}	$V_{IN} = 4.5V$, $V_{EN} < 0.4V$	--	0.1	1	μA
Operation Frequency	F_{OSC}		0.8	1	1.3	MHz
Digital Input High Level	V_{IH}		1.5	--	--	V
Digital Input Low Level	V_{IL}		--	--	0.4	V

Note 1. Stresses beyond those listed “Absolute Maximum Ratings” may cause permanent damage to the device. These are stress ratings only, and functional operation of the device at these or any other conditions beyond those indicated in the operational sections of the specifications is not implied. Exposure to absolute maximum rating conditions may affect device reliability.

Note 2. θ_{JA} is measured at $T_A = 25^\circ\text{C}$ on a low effective thermal conductivity single-layer test board per JEDEC 51-3.

Note 3. Devices are ESD sensitive. Handling precaution is recommended.

Note 4. The device is not guaranteed to function outside its operating conditions.

Typical Operating Characteristics

(For RT9361A, $C_{IN} = C_{OUT} = 2.2\mu F$, $C_{PUMP} = 0.22\mu F$, $T_A = 25^\circ C$, unless otherwise specified)

Output Voltage vs. Output Current

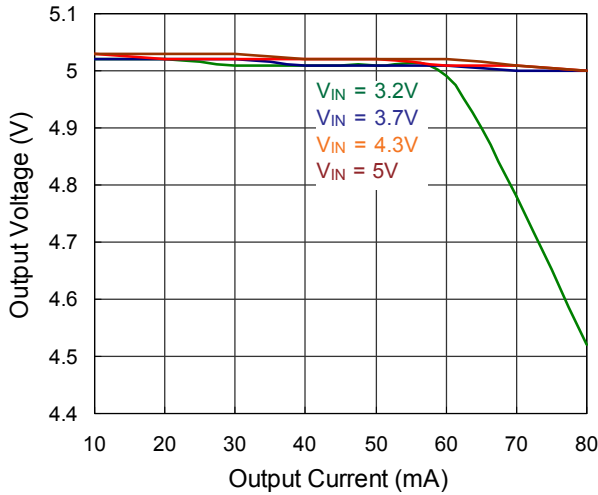

Quiescent Current vs. Input Voltage

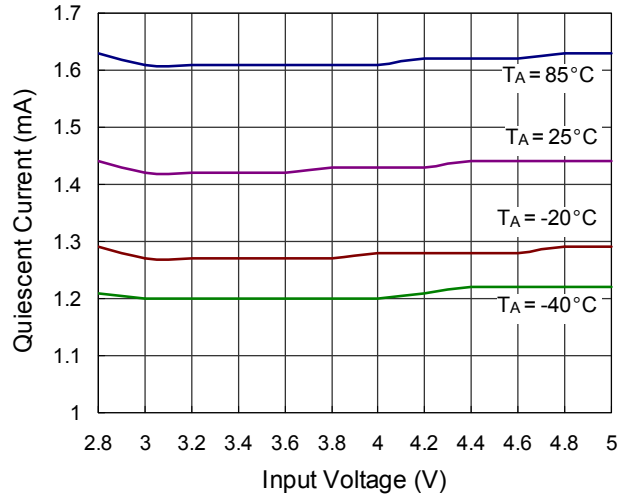

Output Voltage vs. Input Voltage

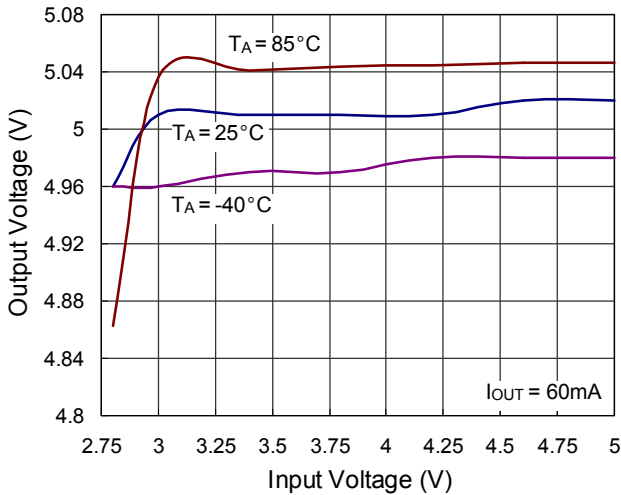

Output Voltage vs. Input Voltage

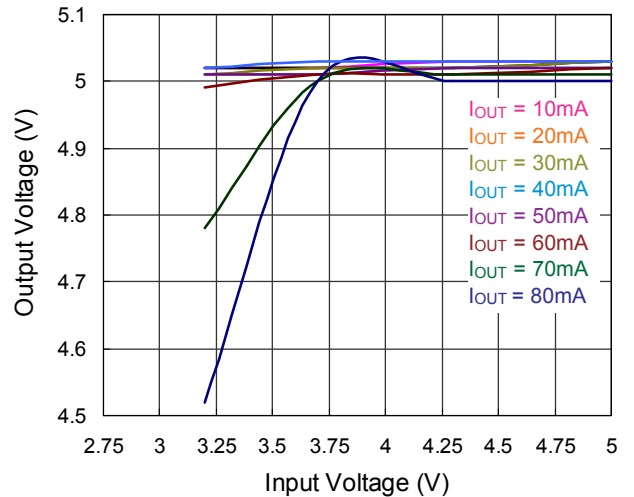

Output Voltage vs. Temperature

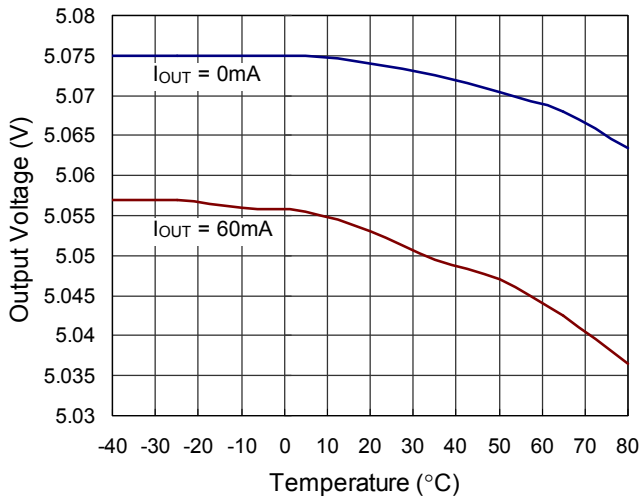

Operation Frequency vs. Temperature

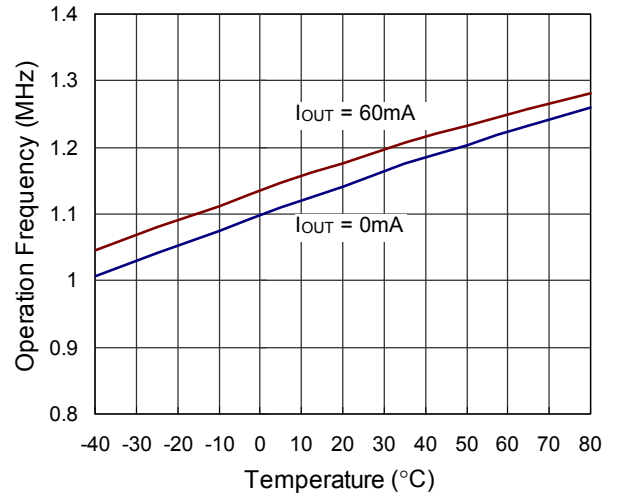

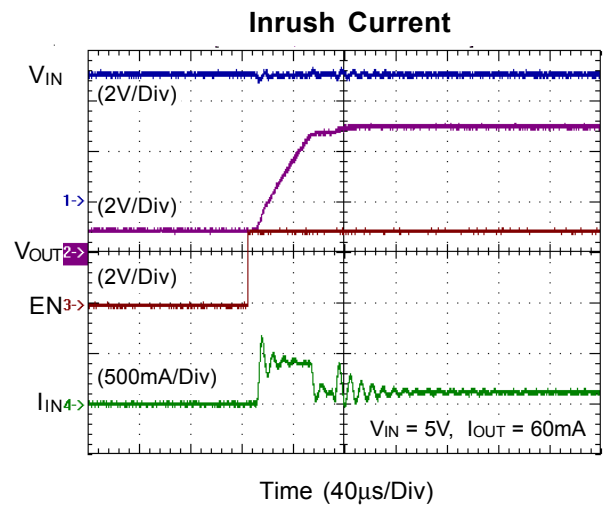
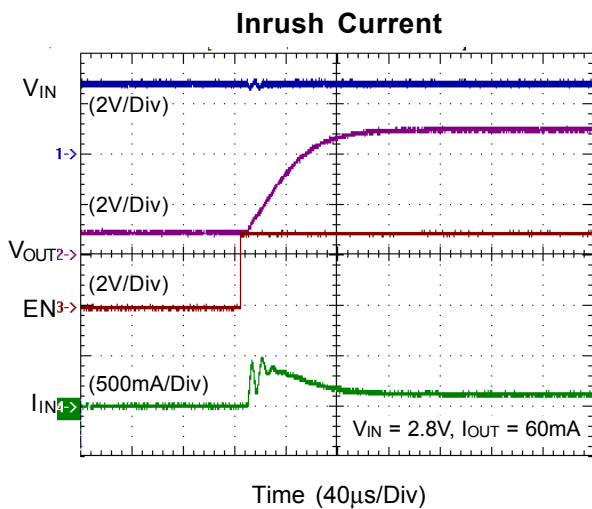
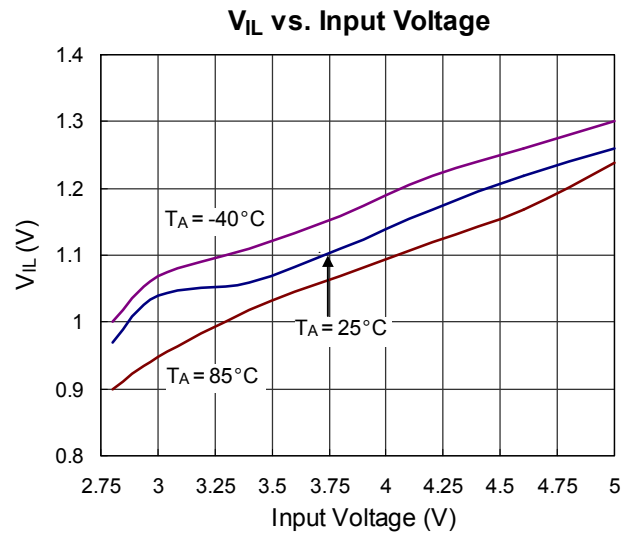
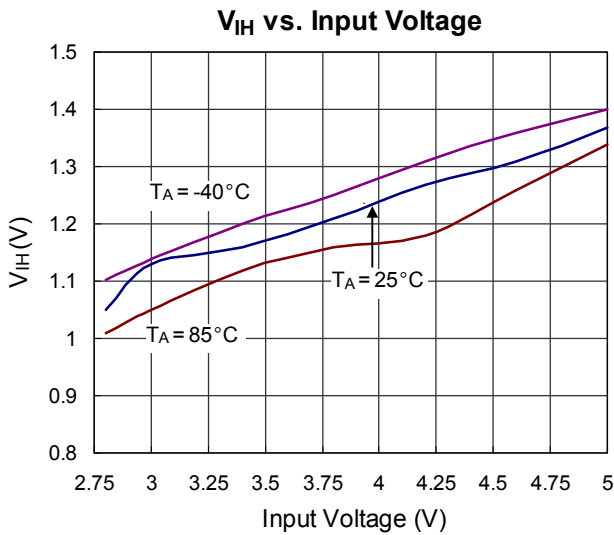
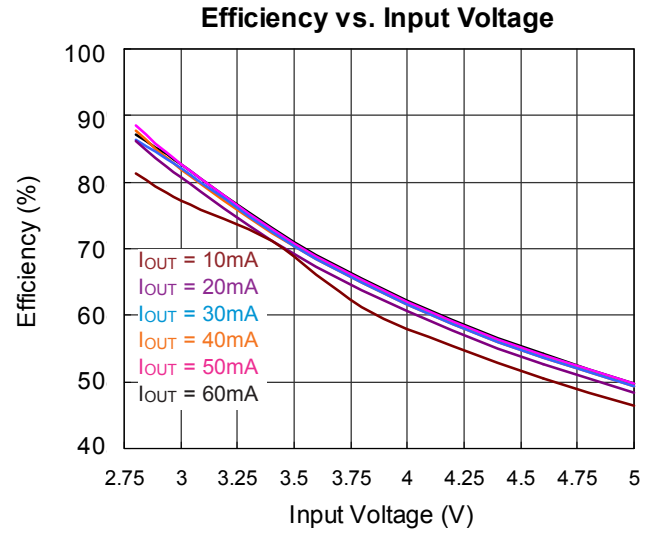
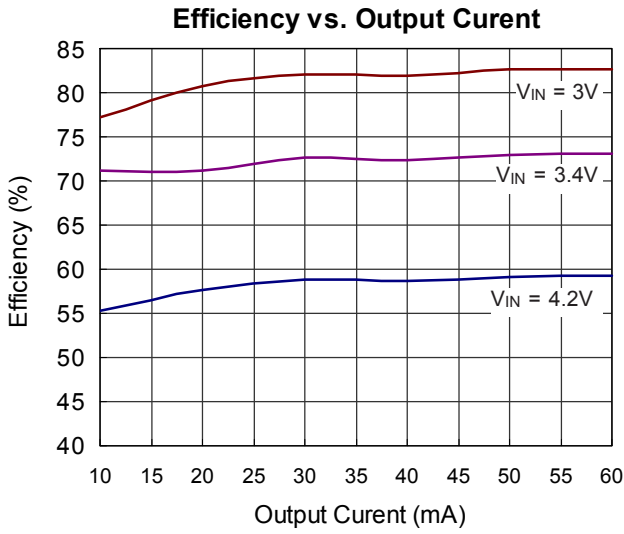

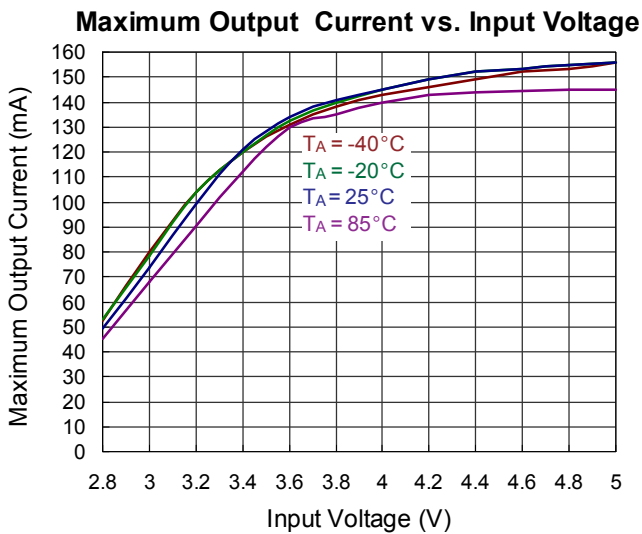
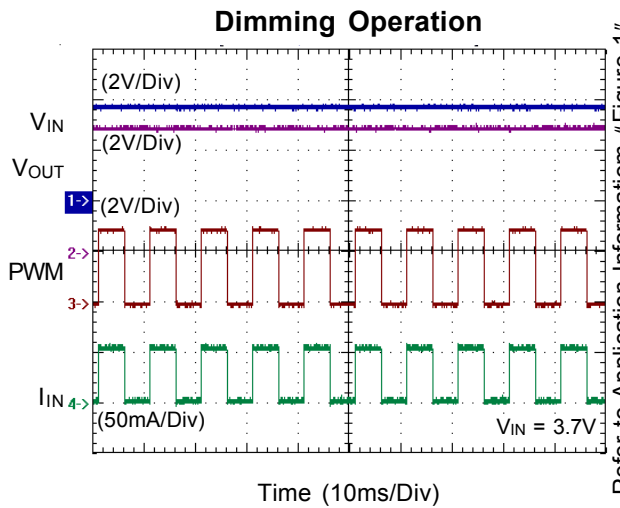
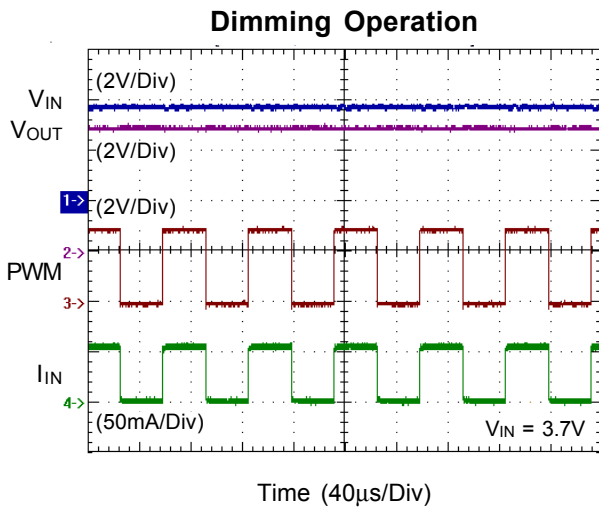
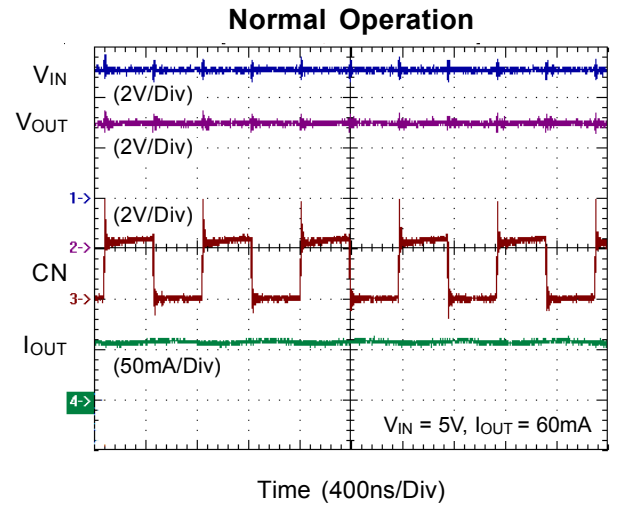
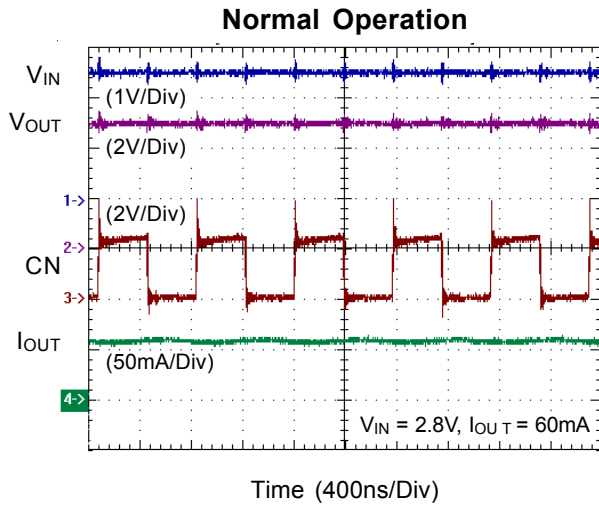

Application Information

Capacitor Selection

Careful selection of the three external capacitors C_{IN} , C_{OUT} and C_{PUMP} is very important because they will affect ramp-up time, output ripple and transient performance. Optimum performance will be obtained when low ESR ($<100m\Omega$) ceramic capacitors are used for C_{IN} and C_{OUT} and C_{PUMP} . In general, low ESR may be defined as less than $100m\Omega$. In all cases, X7R or X5R dielectric are recommended. For particular application, low ESR Tantalum capacitors may be substituted; however optimum output ripple performance may not be realized. Aluminum electrolytic capacitors are not recommended for using with the RT9361A/B due to their inherent high ESR characteristic.

In general, lower values for C_{IN} , C_{OUT} and C_{PUMP} may be utilized for light load current applications ($<60mA$). Drawing a load current of $60mA$ or less may use a C_{IN} and C_{OUT} capacitor value as low as $2.2\mu F$ and a C_{PUMP} value of $0.22\mu F$. C_{IN} and C_{OUT} may range from $1\mu F$ for light loads to $10\mu F$ for heavy output load conditions ($<110mA$). C_{PUMP} may range from $0.22\mu F$ for light loads to $1\mu F$ for heavy output load conditions. If C_{PUMP} is increased, C_{OUT} should also be increased by the same ratio to minimize output ripple. As a basic rule, the ratio between C_{IN} , C_{OUT} and C_{PUMP} should be approximately 10 to 1. Lowering the C_{IN} , C_{OUT} and C_{PUMP} value can decrease the ramp-up time of V_{OUT} , but it will increase the output ripple oppositely.

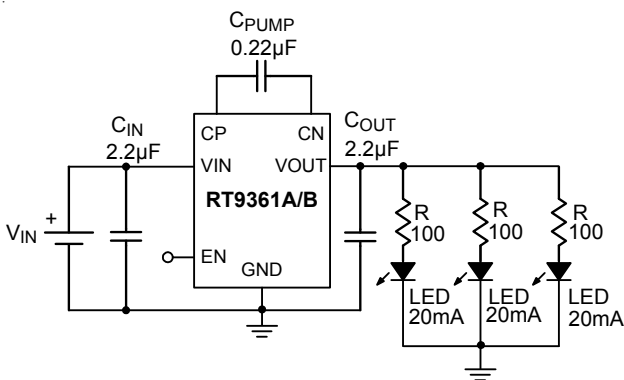

Figure 1. Application Circuits for Backlight Dimming

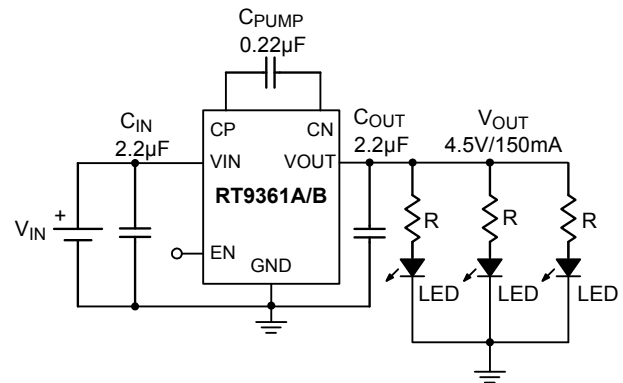

Figure 2. Application Circuits for Flash LEDs

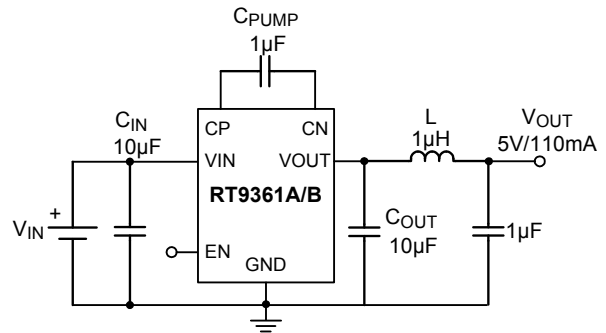

Figure 3. Application Circuits for Constant Load

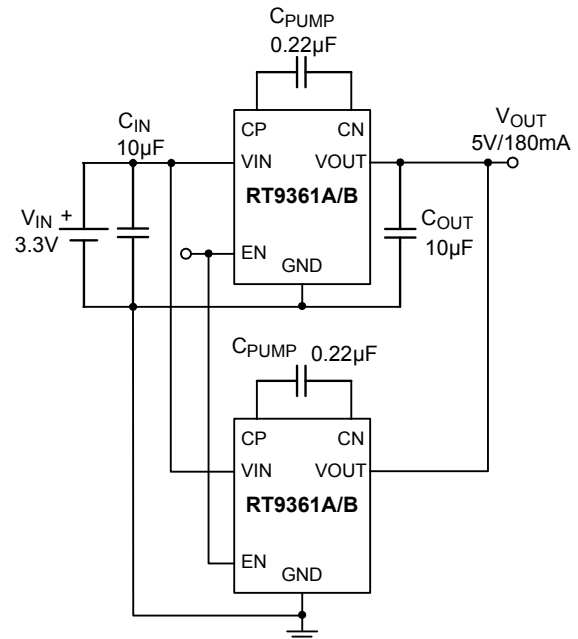

Figure 4. Application Circuits for Doubling the Output Current

Efficiency

The efficiency of the charge pump regulator varies with the output voltage version, the applied input voltage, the load current, and the internal operation mode of the device.

The approximate efficiency is given by :

$$\text{Efficiency (\%)} = \frac{P_{OUT}}{P_{IN}} \times 100 = \frac{V_{OUT} \times I_{OUT}}{V_{IN} \times 2I_{OUT}} \times 100$$

$$= \frac{V_{OUT}}{2V_{IN}} \times 100 \text{ --- (\times 2 Charge Pump Operating Mode)}$$

For a charge pump with an output of 5 volts and a nominal input of 3 volts, the theoretical efficiency is 83.33%. Due to internal switching losses and IC quiescent current consumption, the actual efficiency can be measured as 82.72%.

Thermal Considerations

The maximum power dissipation depends on the thermal resistance of IC package, PCB layout, the rate of surroundings airflow and temperature difference between junction to ambient. The maximum power dissipation can be calculated by following formula :

$$P_{D(MAX)} = (T_{J(MAX)} - T_A) / \theta_{JA}$$

Where $T_{J(MAX)}$ is the maximum operation junction temperature 125°C, T_A is the ambient temperature and the θ_{JA} is the junction to ambient thermal resistance.

For recommended operating conditions specification of RT9361, where $T_{J(MAX)}$ is the maximum junction temperature of the die (125°C) and T_A is the operated ambient temperature. The junction to ambient thermal resistance θ_{JA} for T/SOT-23-6 is 250°C/W and WDFN-6L 2x2 is 165°C/W on the standard JEDEC 51-3 single layer thermal test board. The maximum power dissipation at $T_A = 25^\circ\text{C}$ can be calculated by following formula :

$$P_{D(MAX)} = (125^\circ\text{C} - 25^\circ\text{C}) / 250^\circ\text{C/W} = 0.4\text{W for T/SOT-23-6 packages}$$

$$P_{D(MAX)} = (125^\circ\text{C} - 25^\circ\text{C}) / 165^\circ\text{C/W} = 0.606\text{W for WDFN-6L 2x2 packages}$$

The maximum power dissipation depends on operating ambient temperature for fixed $T_{J(MAX)}$ and thermal resistance θ_{JA} . For RT9361 packages, the Figure 5 of derating curves allows the designer to see the effect of rising ambient temperature on the maximum power allowed.

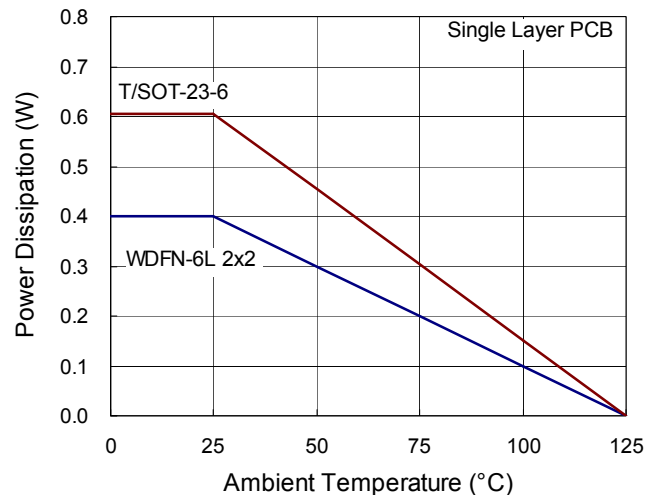

Figure 5. Derating Curves for RT9361 Packages

PCB Board Layout

The RT9361A/B is a high-frequency switched-capacitor converter, and therefore large transient currents will flow in V_{IN} and V_{OUT} . For best performance and to minimize ripple, place all of the components as close to IC as possible. Besides a solid ground plane is recommended on the bottom layer of the PCB. The ground of C_{IN} and C_{OUT} should be connected together and as close to the IC as possible. Figure 6 and Figure 7 shows the typical PCB layout of RT9361A/B EVB board.

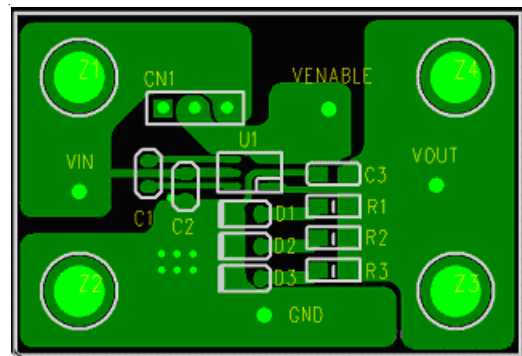

Figure 6

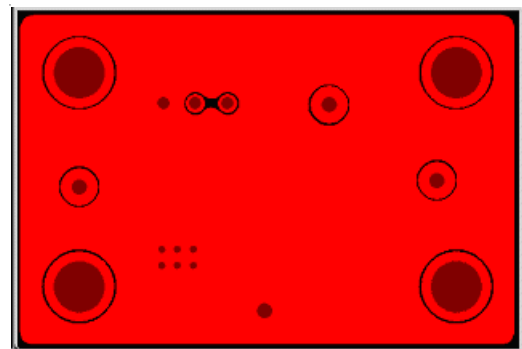
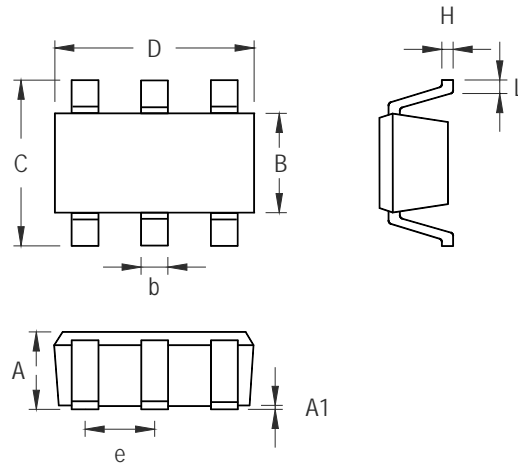

Figure 7

Outline Dimension



Symbol	Dimensions In Millimeters		Dimensions In Inches	
	Min	Max	Min	Max
A	0.889	1.295	0.031	0.051
A1	0.000	0.152	0.000	0.006
B	1.397	1.803	0.055	0.071
b	0.250	0.560	0.010	0.022
C	2.591	2.997	0.102	0.118
D	2.692	3.099	0.106	0.122
e	0.838	1.041	0.033	0.041
H	0.080	0.254	0.003	0.010
L	0.300	0.610	0.012	0.024

SOT-23-6 Surface Mount Package

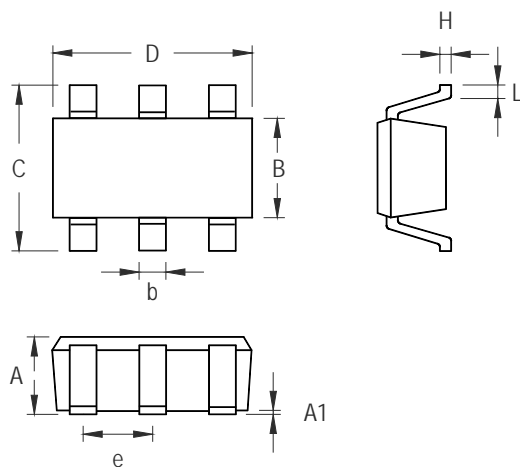

Symbol	Dimensions In Millimeters		Dimensions In Inches	
	Min	Max	Min	Max
A	0.700	1.000	0.028	0.039
A1	0.000	0.100	0.000	0.004
B	1.397	1.803	0.055	0.071
b	0.300	0.559	0.012	0.022
C	2.591	3.000	0.102	0.118
D	2.692	3.099	0.106	0.122
e	0.838	1.041	0.033	0.041
H	0.080	0.254	0.003	0.010
L	0.300	0.610	0.012	0.024

TSOT-23-6 Surface Mount Package

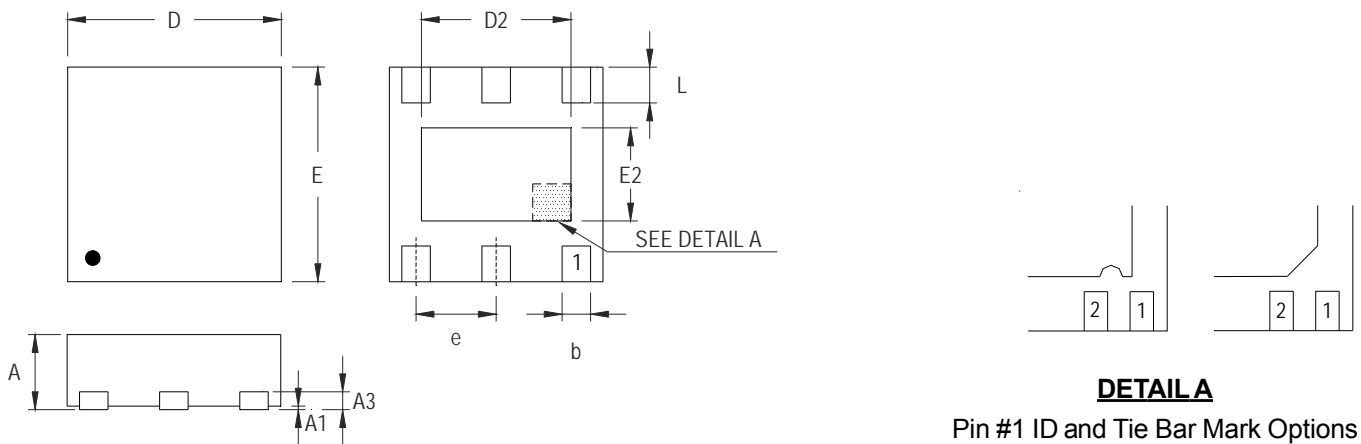

DETAIL A

Pin #1 ID and Tie Bar Mark Options

Note : The configuration of the Pin #1 identifier is optional, but must be located within the zone indicated.

Symbol	Dimensions In Millimeters		Dimensions In Inches	
	Min	Max	Min	Max
A	0.700	0.800	0.028	0.031
A1	0.000	0.050	0.000	0.002
A3	0.175	0.250	0.007	0.010
b	0.200	0.350	0.008	0.014
D	1.950	2.050	0.077	0.081
D2	1.000	1.450	0.039	0.057
E	1.950	2.050	0.077	0.081
E2	0.500	0.850	0.020	0.033
e	0.650		0.026	
L	0.300	0.400	0.012	0.016

W-Type 6L DFN 2x2 Package

Richtek Technology Corporation

14F, No. 8, Tai Yuen 1st Street, Chupei City
 Hsinchu, Taiwan, R.O.C.
 Tel: (8863)5526789

Richtek products are sold by description only. Richtek reserves the right to change the circuitry and/or specifications without notice at any time. Customers should obtain the latest relevant information and data sheets before placing orders and should verify that such information is current and complete. Richtek cannot assume responsibility for use of any circuitry other than circuitry entirely embodied in a Richtek product. Information furnished by Richtek is believed to be accurate and reliable. However, no responsibility is assumed by Richtek or its subsidiaries for its use; nor for any infringements of patents or other rights of third parties which may result from its use. No license is granted by implication or otherwise under any patent or patent rights of Richtek or its subsidiaries.

单击下面可查看定价，库存，交付和生命周期等信息

[>>Richtek\(台湾立锜\)](#)