

# RT5047AGSP Single Output LNB Supply and Control Voltage Regulator

## ***Purpose***

The RT5047A is a highly integrated voltage regulator and interface IC, specifically design for supplying power and control signals from advanced satellite set-top box (STB) modules to the LNB down-converter in the antenna dish or to the multi-switch box. This document explains the function and use of the RT5047A evaluation board (EVB), and provides information to enable operation, modification of the evaluation board and circuit to suit individual requirements.

## **Table of Contents**

Purpose .....	1
Introduction.....	2
Key Performance Summary Table .....	2
Bench Test Setup Conditions .....	3
Schematic, Bill of Materials & Board Layout .....	4
More Information.....	7
Important Notice for Richtek Evaluation Board .....	7

## Introduction

### General Product Information

The device consists of the independent current-mode boost controller and low dropout linear regulator along with the circuitry required for 22kHz tone shaping to support DiSEqC™ 1.x communications. The RT5047A provides fault protections including over-current, over-temperature and under-voltage lockout.

The RT5047A is available in a SOP-8 (Exposed Pad) package to achieve optimized solution for thermal dissipation.

### Product Feature

- Wide Input Supply Voltage Range : 8V to 16V
- Output Current Limit of 550mA with 45ms timer
- Low Noise LNB Output Voltage (13.3V and 18.3V by SEL Pin)
- ±3% High Accuracy for 0mA to 500mA Current Output
- Push-Pull Output Stage minimizes 13.3V to 18.3V and 18.3V to 13.3V Output Transition Time
- External 22kHz Tone Input
- Meet DiSEqC™ 1.x Protocol
- Output Short Circuit Protection
- Over-temperature Protection

### Key Performance Summary Table

Key Features	Evaluation Board Number : PCB014_V1
Default Input Voltage	12V
Max Output Current	500mA
Default Output Voltage	Low is for 13.3V, high is for 18.3V
Default Marking & Package Type	RT5047AGSP, SOP-8 (Exposed Pad)
Operation Frequency	700kHz (Typ.)

## Bench Test Setup Conditions

### Headers Description and Placement

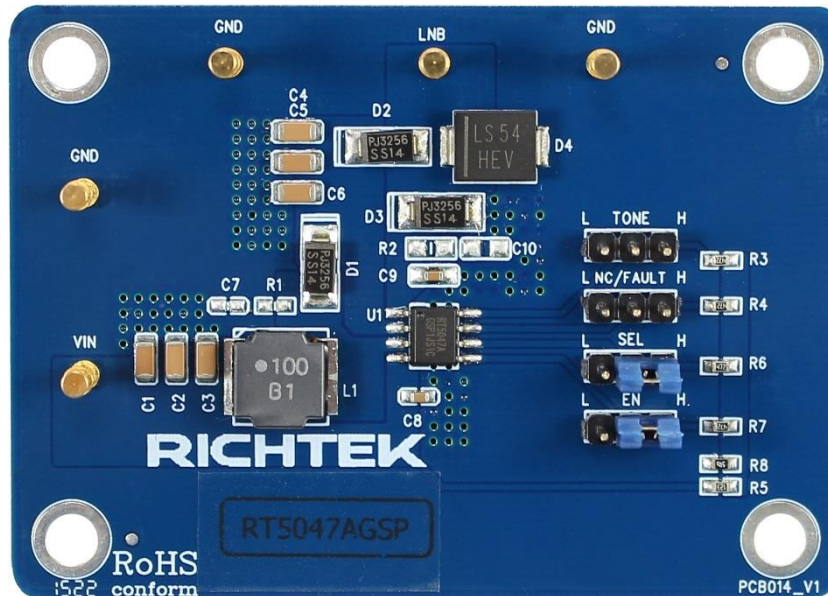

Please carefully inspect the EVB IC and external components, comparing them to the following Bill of Materials, to ensure that all components are installed and undamaged. If any components are missing or damaged during transportation, please contact the distributor or send e-mail to [evb\\_service@richtek.com](mailto:evb_service@richtek.com)

### Test Points

The EVB is provided with the test points and pin names listed in the table below.

Test point/ Pin name	Signal	Comment (expected waveforms or voltage levels on test points)
<b>LNB</b>	LNB output pin	Output Voltage for LNB. Output capacitor should not higher than 4.7 $\mu$ F.
<b>BOOST</b>	Boost feedback point	Boost Output and Tracking Supply Voltage to LNB.
<b>LX</b>	Switch node	Switching Node of DC/DC Boost Converter.
<b>VIN</b>	Input voltage	Power Supply Input.
<b>EN</b>	Enable point	High to enable the LNB and low to disable the LNB.
<b>SEL</b>	Output level select point	Low for VLNB is 13.3V and high for VLNB is 18.3V.
<b>FAULT</b>	Fault detect point	Open drain. Pull to 3.3V by 4.7k $\Omega$ resistor. This pin will pull to low when OCP trigger.
<b>TONE</b>	TONE input signal	Supply a 22kHz signal at this pin to control the output tone signal.
<b>GND</b>	Ground	The Exposed Pad must be soldered to a large PCB and connected to GND for maximum power dissipation.

### Power-up & Measurement Procedure

1. Connect input power ( $8V < V_{IN} < 16V$ ) and input ground to VIN and GND test pins respectively.
2. To use a jumper at "H" option to tie EN test pin for enabling the device. Inversely, to use a jumper at "L" option to tie EN test pin and ground GND for disabling the device.
3. Supply a 22kHz signal of the "TONE" pin to adjust the output tone signal.
4. Verify the output voltage between LNB and GND.
5. Connect an external load up to 0.45A to the VOUT and GND terminals and verify the output voltage and current.

### Schematic, Bill of Materials & Board Layout

#### EVB Schematic Diagram

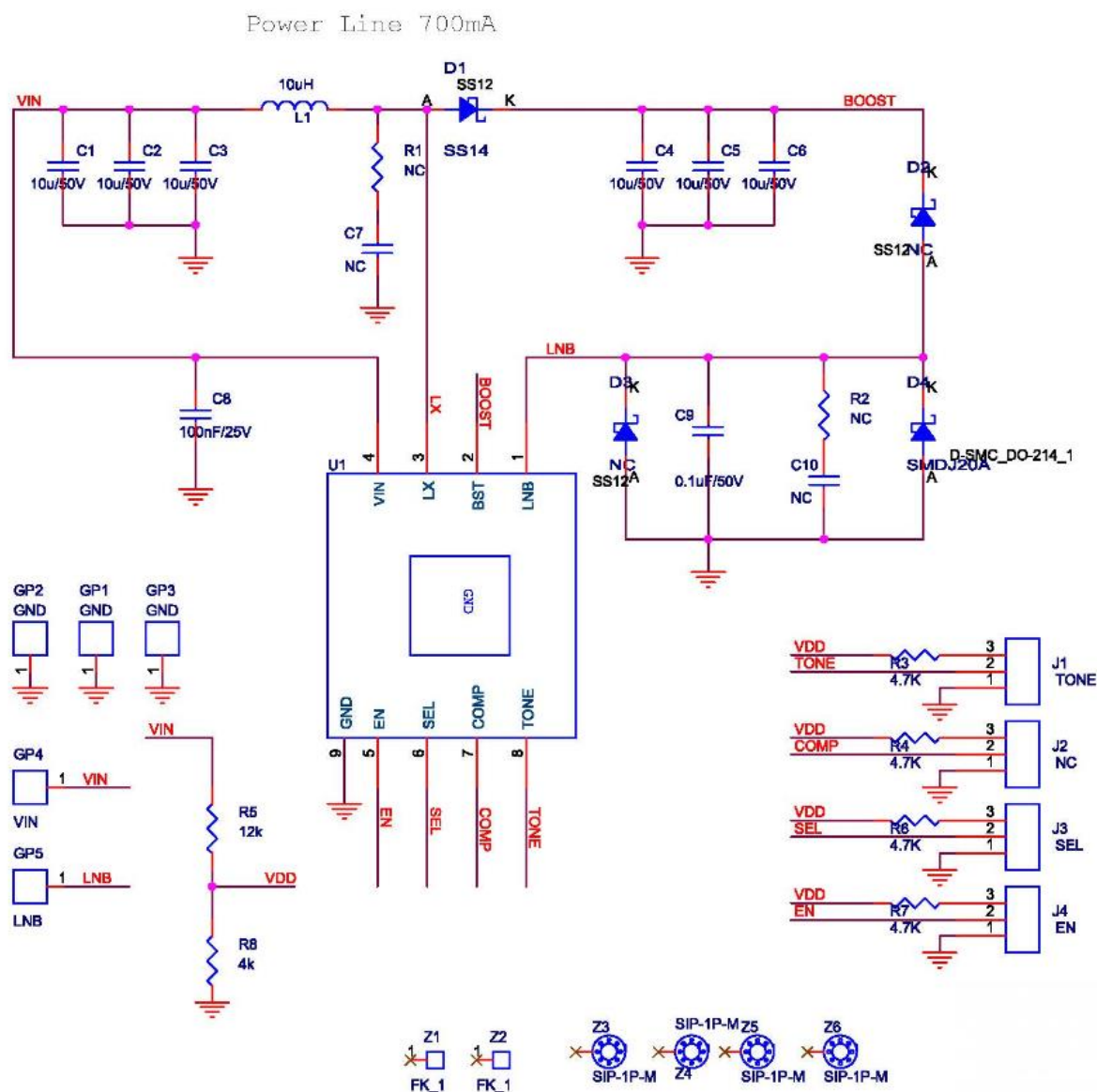

**Bill of Materials**

Reference	Qty	Part Number	Description	Package	Manufacture
U1	1	RT5047AGSP	Voltage Regulator	SOP-8 (Exposed Pad)	RICHTEK
C1, C2, C3, C4, C5, C6	6		10 $\mu$ F/50V	C-0805	
C8	1		100nF/25V	C-0603	
C9	1		0.1 $\mu$ F/50V	C-0805	
C10	1		NC		
R1, C7	2		NC		
R2	1		NC		
R3, R4, R6, R7	4		4.7k	R-0603	
R5	1		12k	R-0603	
R8	1		4k	R-0603	
L1	1		10 $\mu$ H	L-NR8040_2	
GP1, GP2, GP3	3		GND	SIP-1P-GP	
GP4	1		VIN	SIP-1P-GP	
GP5	1		LNB	SIP-1P-GP	
D1, D2, D3	3		SS14	SS14	
D4	1		SMDJ20A	D-SMC_DO-214_1	
J1	1		TONE	SIP-3P	
J2	1		NC	SIP-3P	
J3	1		SEL	SIP-3P	
J4	1		EN	SIP-3P	
Z1, Z2	2		FK_1	FK_1	
Z3, Z4, Z5, Z6	4		SIP-1P-M	SIP-1P-M	

**PCB Layout**

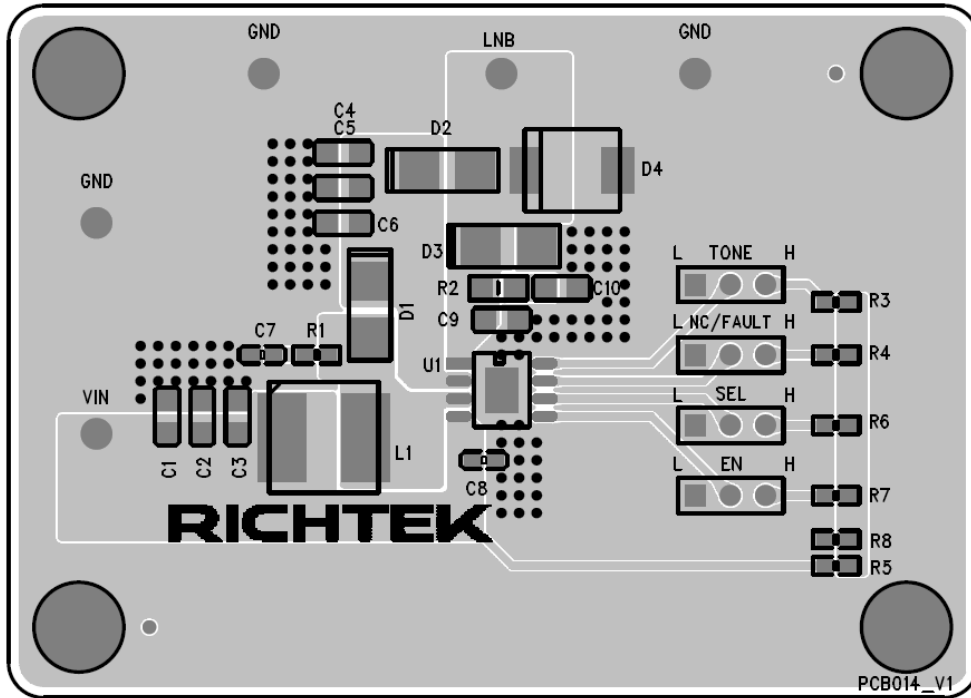

Top View

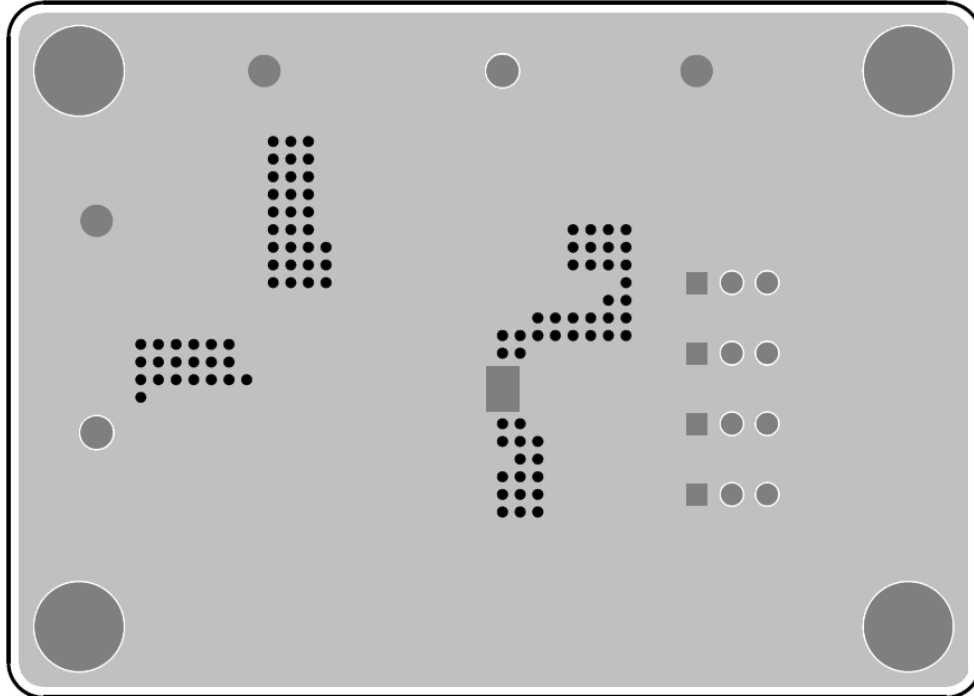

Bottom View

### ***More Information***

For more information, please find the related datasheet or application notes from Richtek website <http://www.richtek.com>.

### ***Important Notice for Richtek Evaluation Board***

THIS DOCUMENT IS FOR REFERENCE ONLY, NOTHING CONTAINED IN THIS DOCUMENT SHALL BE CONSTRUED AS RICHTEK'S WARRANTY, EXPRESS OR IMPLIED, UNDER CONTRACT, TORT OR STATUTORY, WITH RESPECT TO THE PRESENTATION HEREIN. IN NO EVENT SHALL RICHTEK BE LIABLE TO BUYER OR USER FOR ANY AND ALL DAMAGES INCLUDING WITHOUT LIMITATION TO DIRECT, INDIRECT, SPECIAL, PUNITIVE OR CONSEQUENTIAL DAMAGES.

单击下面可查看定价，库存，交付和生命周期等信息

[>>Richtek\(台湾立锜\)](#)