

DDR Termination Regulator

General Description

The RT2568 is a sink/source tracking termination regulator. It is specifically designed for low-cost and low-external component count systems. The RT2568 possesses a high speed operating amplifier that provides fast load transient response and only requires a minimum 10 μ F x 3 ceramic output capacitor. The RT2568 supports remote sensing functions and all features required to power the DDRIII and Low Power DDRIII / DDRIV VTT bus termination according to the JEDEC specification. In addition, the RT2568 provides an open-drain PGOOD signal to monitor the output regulation and an EN signal that can be used to discharge VTT during S3 (suspend to RAM) for DDR applications.

The RT2568 is available in the thermal efficient package, WDFN-10L 3x3.

Features

- VIN Input Voltage Range : 1.1V to 3.5V
- VCNTL Input Voltage Range : 2.9V to 5.5V
- Support Ceramic Capacitors
- Power Good Indicator
- 10mA Source/Sink Reference Output
- Meet DDRI, DDRII JEDEC Spec
- Support DDRI, DDRII, DDRIII and Low Power DDRIII/DDRIV VTT Applications
- Soft-Start Function
- UVLO and OCP Protection
- Thermal Shutdown

Applications

- Notebook/Desktop/Server
- Telecom/Datacom, GSM Base Station, LCD-TV/PDP-TV, Copier/Printer, Set-Top Box

Simplified Application Circuit

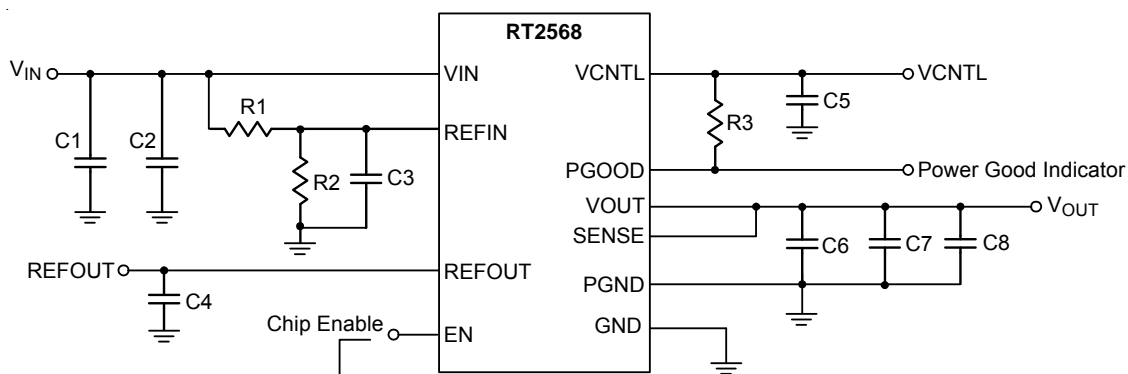

Ordering Information

RT2568□□

- Package Type
QW : WDFN-10L 3x3 (W-Type)
- Lead Plating System
G : Green (Halogen Free and Pb Free)

RT2568□□□

- Pin 1 Orientation***
(2) : Quadrant 2, Follow EIA-481-D
- Package Type
QW : WDFN-10L 3x3 (W-Type)
- Lead Plating System
G : Green (Halogen Free and Pb Free)

Pin Configuration

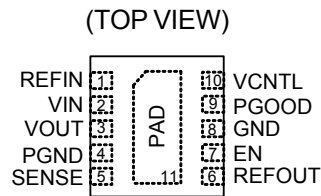

WDFN-10L 3x3

Marking Information

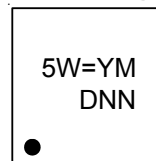

5W= : Product Code
YMDNN : Date Code

Note :

***Empty means Pin1 orientation is Quadrant 1

Richtek products are :

- ▶ RoHS compliant and compatible with the current requirements of IPC/JEDEC J-STD-020.
- ▶ Suitable for use in SnPb or Pb-free soldering processes.

Functional Pin Description

Pin No.	Pin Name	Pin Function
1	REFIN	Reference input.
2	VIN	Power input of the regulator.
3	VOUT	Power output of the regulator.
4	PGND	Power ground of the regulator.
5	SENSE	Voltage sense input for the regulator. Connect to positive terminal of the output capacitor or the load.
6	REFOUT	Reference output. Connect to GND through a 0.1μF ceramic capacitor.
7	EN	Enable control input. For DDR VTT application, connect EN to SLP_S3. For other applications, use EN as the ON/OFF function.
9	PGOOD	Power good open-drain output. Connect a pull-up resistor between this pin and VCNTL pin.
10	VCNTL	Control voltage input. Connect this pin to the 3.3V or 5V power supply. A ceramic decoupling capacitor with a value 4.7μF is required.
8	GND	Analog ground. Connect to negative terminal of the output capacitor.
11 (Exposed Pad)	PAD	Exposed pad. The exposed pad is internally unconnected and must be soldered to a large PGND plane. Connect this PGND plane to other layers with thermal vias to help dissipate heat from the device.

Functional Block Diagram

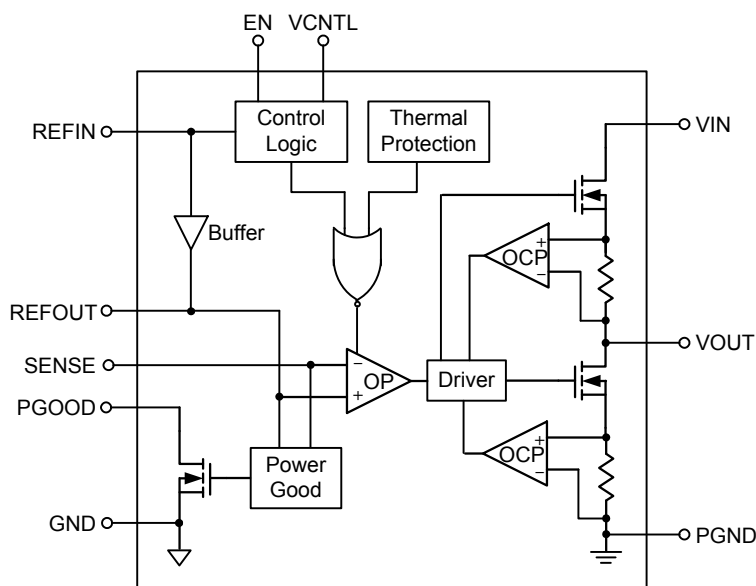

Operation

The RT2568 is a linear sink/source DDR termination regulator with current capability up to 3A. The RT2568 builds in a high-side N-MOSFET which provides current sourcing and a low-side N-MOSFET which provides current sinking. All the control circuits are supplied by the power VCNTL. In normal operation, the error amplifier OP adjusts the gate driving voltage of the power MOSFET to achieve SENSE voltage well tracking the REFIN voltage.

Both the source and sink currents are detected by the internal sensing resistor, and the OCP function will work to limit the current to a designed value when overload happens. Furthermore, the current will be folded back to be one half if VOUT is out of the power good window.

Buffer

This function provides REFOUT output equal to V_{REFIN} with 10mA source/sink current capability.

Power Good

When the SENSE voltage is in the power good window and lasts for a certain delay time, then the PGOOD pin will be high impedance and the PGOOD voltage will be pulled high by the external resistor.

Over-Current Protection

The device continuously monitors the output current to protect the pass transistor against abnormal operations. The current limit (I_{LIM}) level reduces to one-third when the output voltage is not within the powergood window. This reduction is a non-latch protection.

Control Logic

This block includes VCNTL UVLO, REFIN UVLO and Enable/Disable functions, and provides logic control to the whole chip.

Thermal Protection

Both the high-side and low-side power MOSFETs will be turned off when the junction temperature is higher than typically 160°C, and be released to normal operation when junction temperature falls below 120°C typically.

Absolute Maximum Ratings (Note 1)

• Supply Voltage, V_{IN} , V_{CNTL}	-0.3V to 6V
• Input Voltage, EN, REFIN, SENSE	-0.3V to 6V
• Output Voltage, V_{OUT} , REFOUT, PGOOD	-0.3V to 6V
• Power Dissipation, P_D @ $T_A = 25^\circ\text{C}$	
WDFN-10L 3x3	2.5W
• Package Thermal Resistance (Note 2)	
WDFN-10L 3x3, θ_{JA}	40°C/W
WDFN-10L 3x3, θ_{JC}	7.5°C/W
• Lead Temperature (Soldering, 10 sec.)	260°C
• Junction Temperature	150°C
• Storage Temperature Range	-65°C to 150°C
• ESD Susceptibility (Note 3)	
HBM (Human Body Model)	2kV
MM (Machine Model)	200V
CDM (Charged Device Model)	2kV

Recommended Operating Conditions (Note 4)

• Control Input Voltage, V_{CNTL}	2.9V to 5.5V
• Supply Input Voltage, V_{IN}	1.1V to 3.5V
• Junction Temperature Range	-40°C to 125°C

Electrical Characteristics

($V_{IN} = 1.5\text{V}$, $V_{EN} = V_{CNTL} = 3.3\text{V}$, $V_{REFIN} = V_{SENSE} = 0.75\text{V}$, $C_{OUT} = 10\mu\text{F} \times 3$, $T_A = -40^\circ\text{C}$ to 85°C , unless otherwise specified)

Parameter	Symbol	Test Conditions	Min	Typ	Max	Unit
Supply Current						
VCNTL Supply Current	I_{VCNTL}	$V_{EN} = V_{CNTL}$, no load	--	0.7	1	mA
VCNTL Shutdown Current	I_{SHDN_VCNTL}	$V_{EN} = 0\text{V}$, $V_{REFIN} = 0\text{V}$, no load	--	65	80	μA
		$V_{EN} = 0\text{V}$, $V_{REFIN} > 0.4\text{V}$, no load	--	200	400	
V_{IN} Supply Current	I_{VIN}	$V_{EN} = V_{CNTL}$, no load	--	1	50	μA
V_{IN} Shutdown Current	I_{SHDN_VIN}	$V_{EN} = 0\text{V}$, no load	--	0.1	50	μA
Output						
VTT Output Voltage	V_{OUTO}	$V_{IN} = 1.5\text{V}$, $V_{REFIN} = 0.75\text{V}$, $I_{OUT} = 0\text{A}$	--	0.75	--	V
		$V_{IN} = 1.35\text{V}$, $V_{REFIN} = 0.675\text{V}$, $I_{OUT} = 0\text{A}$	--	0.675	--	
		$V_{IN} = 1.2\text{V}$, $V_{REFIN} = 0.6\text{V}$, $I_{OUT} = 0\text{A}$	--	0.6	--	
VTT Output Voltage Offset	V_{OUT_OS}	$I_{OUT} < \pm 2\text{A}$, $V_{LDoin} = 1.5\text{V}$, $V_{OUT_OS} = V_{OUT} - V_{OUTO}$	-25	--	25	mV
		$I_{OUT} < \pm 2\text{A}$, $V_{LDoin} = 1.35\text{V}$, $V_{OUT_OS} = V_{OUT} - V_{OUTO}$	-25	--	25	
		$I_{OUT} < \pm 2\text{A}$, $V_{LDoin} = 1.2\text{V}$, $V_{OUT_OS} = V_{OUT} - V_{OUTO}$	-25	--	25	

Parameter	Symbol	Test Conditions	Min	Typ	Max	Unit
VOUT Source Current Limit	I _{LIM_VOUT_SR}	VOUT in PGOOD window	3	4.5	--	A
VOUT Sink Current Limit	I _{LIM_VOUT_SK}	VOUT in PGOOD window	3	4.5	--	A
VOUT Discharge Resistance	R _{DISCHARGE}	V _{REFIN} = 0V, V _{OUT} = 0.3V, V _{EN} = 0V	--	18	25	Ω
Power Good Comparator						
PGOOD Threshold	V _{TH_PGOOD}	V _{SENSE} lower threshold with respect to REFOUT	--	-20	--	%
		V _{SENSE} upper threshold with respect to REFOUT	--	20	--	
		PGOOD hysteresis	--	5	--	
PGOOD Start-Up Delay	T _{PGDELAY1}	Start-up rising delay, V _{SENSE} within PGOOD range	--	2	--	ms
Output Low Voltage	V _{LOW_PGOOD}	I _{PGOOD} = 4mA	--	--	0.4	V
PGOOD Falling Delay	T _{PGDELAY2}	Falling delay, V _{SENSE} is out of PGOOD range	--	10	--	μs
Leakage Current	I _{LEAKAGE_PGOOD}	V _{SENSE} = V _{REFIN} (PGOOD high impedance), V _{PGOOD} = V _{CNTL} + 0.2V	--	--	1	μA
REFIN and REFOUT						
REFIN Input Current	I _{REFIN}	V _{EN} = V _{CNTL}	--	--	1	μA
REFIN Voltage Range	V _{REFIN}		0.5	--	1.8	V
REFIN Under-Voltage Lockout	V _{UVLO_REFIN}	REFIN rising	360	390	420	mV
		Hysteresis	--	20	--	
REFOUT Voltage Tolerance to V _{REFIN}	V _{TOL_REFOUT}	-10mA < I _{REFOUT} < 10mA, V _{REFIN} = 0.75V	-15	--	15	mV
		-10mA < I _{REFOUT} < 10mA, V _{REFIN} = 0.675V	-15	--	15	
		-10mA < I _{REFOUT} < 10mA, V _{REFIN} = 0.6V	-15	--	15	
REFOUT Source Current Limit	I _{LIM_REFOUT_SR}	V _{REFOUT} = 0V	10	40	--	mA
REFOUT Sink Current Limit	I _{LIM_REFOUT_SK}	V _{REFOUT} = REFIN + 1V	10	40	--	mA
UVLO/EN						
UVLO Threshold	V _{UVLO_VCNTL}	Rising	2.5	2.7	2.85	V
		Hysteresis	--	120	--	mV
EN Input Voltage	Logic-High	V _{IN_H}	1.7	--	--	V
	Logic-Low	V _{IN_L}	--	--	0.3	
Thermal Shutdown						
Thermal Shutdown Threshold	T _{SD}	Shutdown temperature (Note 5)	--	160	--	°C
		Hysteresis (Note 5)	--	15	--	

- Note 1.** Stresses beyond those listed under “Absolute Maximum Ratings” may cause permanent damage to the device. These are stress ratings only, and functional operation of the device at these or any other conditions beyond those indicated in the operational sections of the specifications is not implied. Exposure to absolute maximum rating conditions may affect device reliability.
- Note 2.** θ_{JA} is measured at $T_A = 25^\circ\text{C}$ on a high effective thermal conductivity four-layer test board per JEDEC 51-7. θ_{JC} is measured at the exposed pad of the package.
- Note 3.** Devices are ESD sensitive. Handling precaution is recommended.
- Note 4.** The device is not guaranteed to function outside its operating conditions.
- Note 5.** Guarantee by design.

Typical Application Circuit

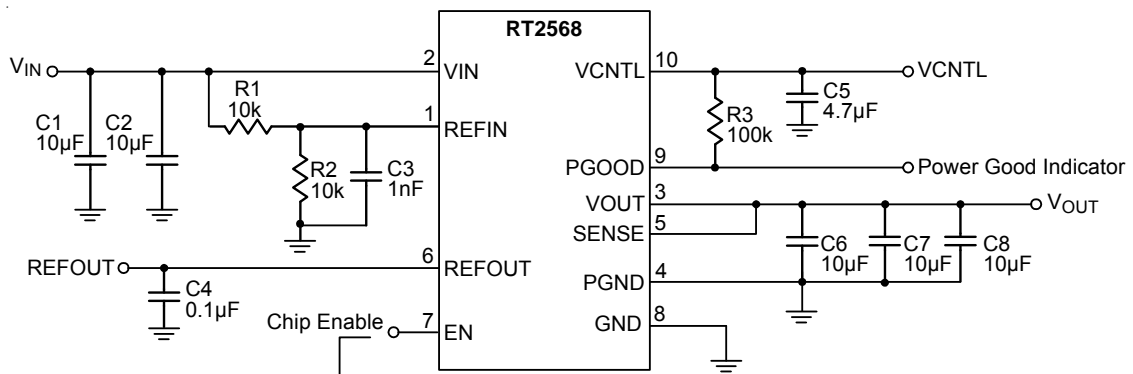
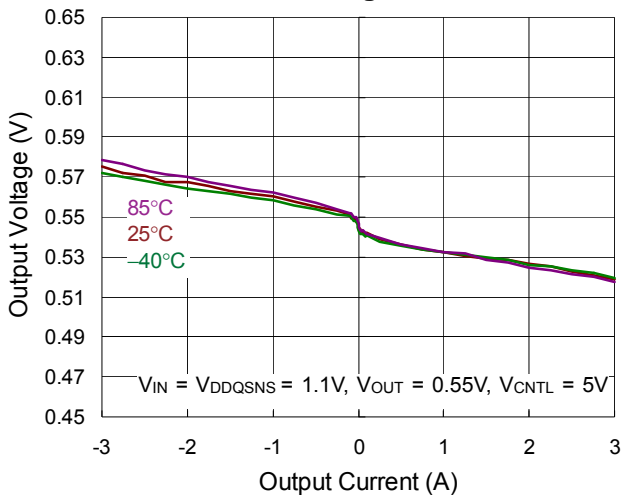

Table 1. Recommended External Components

Component	Description	Vendor P/N
C1, C2, C6, C7, C8	10µF, 6.3V, X7R, 0805	GRM21BR70J106KE76L (Murata) CGA4J1X7R0J106K125AC (TDK)
C3	1nF, 50V, X7R, 0603	GCD188R71H102KA01D (Murata) CGA3E2X7R1H102K080AA (TDK)
C4	0.1µF, 16V, X7R, 0603	GCJ188R71C104KA01D (Murata)
C5	4.7µF, 6.3V, X5R, 0603	GRT188R60J475ME01D (Murata) CGB3B3X5R0J475M055AB(TDK)

Typical Operating Characteristics

Load Regulation



Load Regulation

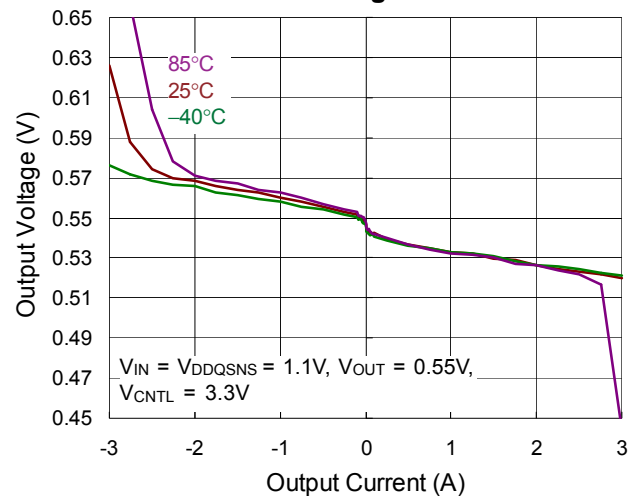

Load Regulation

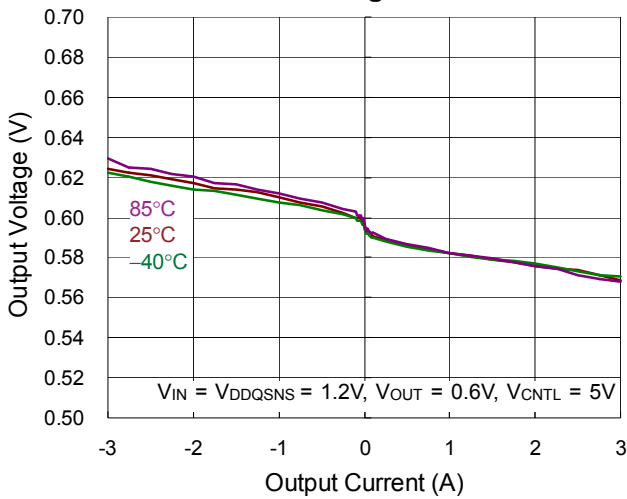

Load Regulation

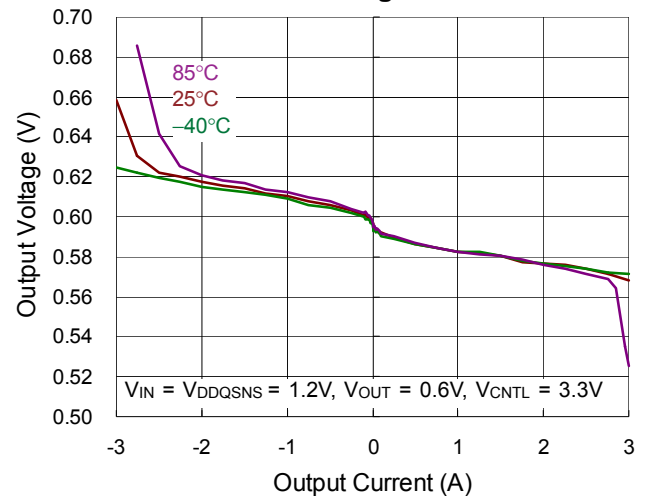

Load Regulation

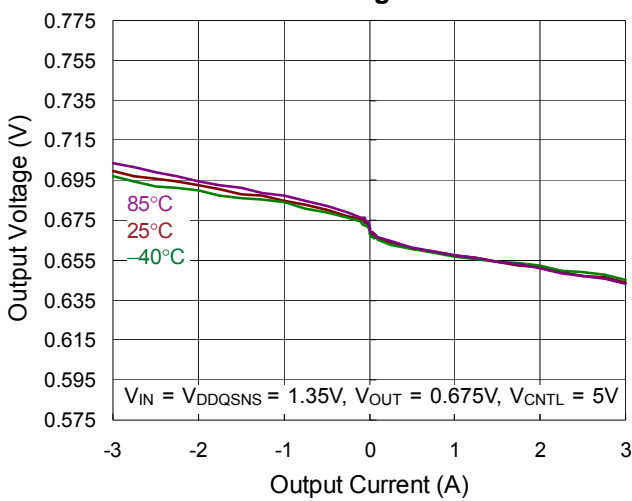

Load Regulation

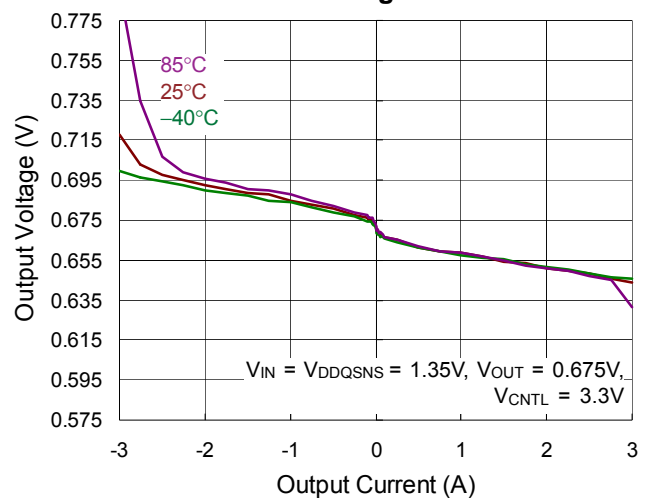

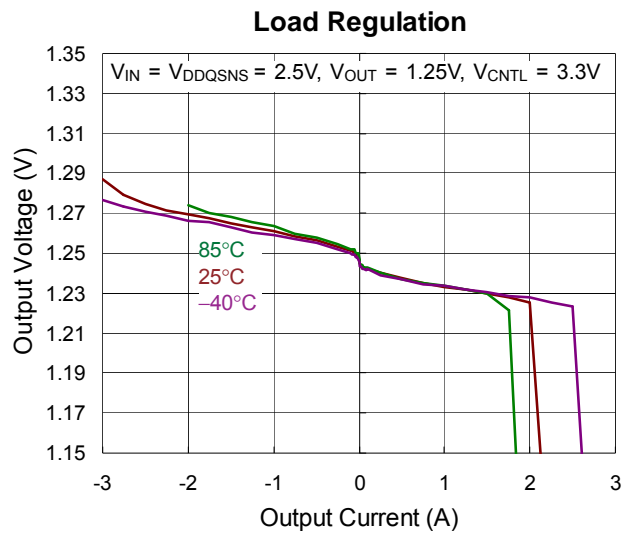
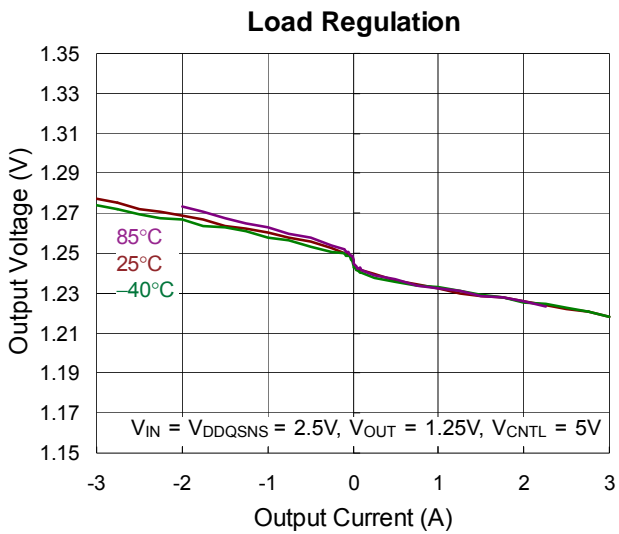
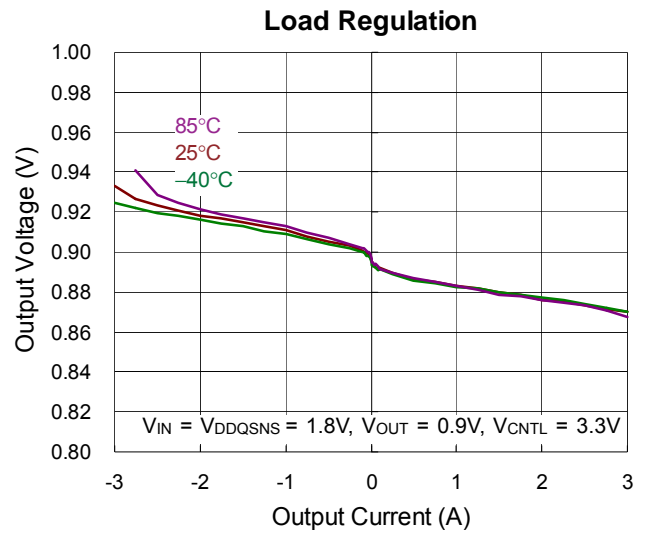
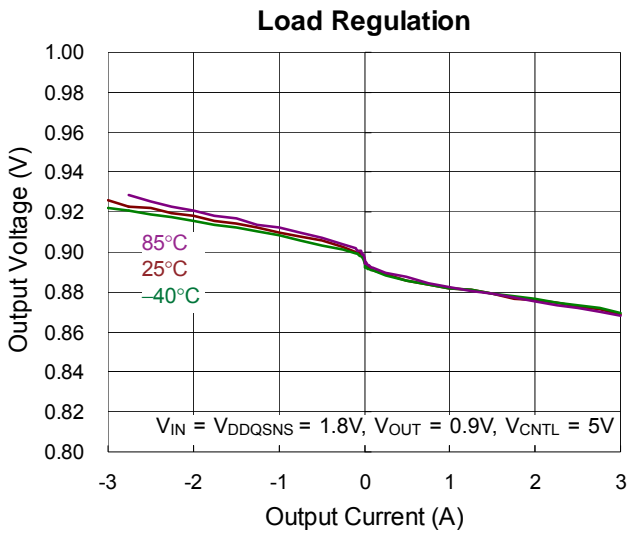
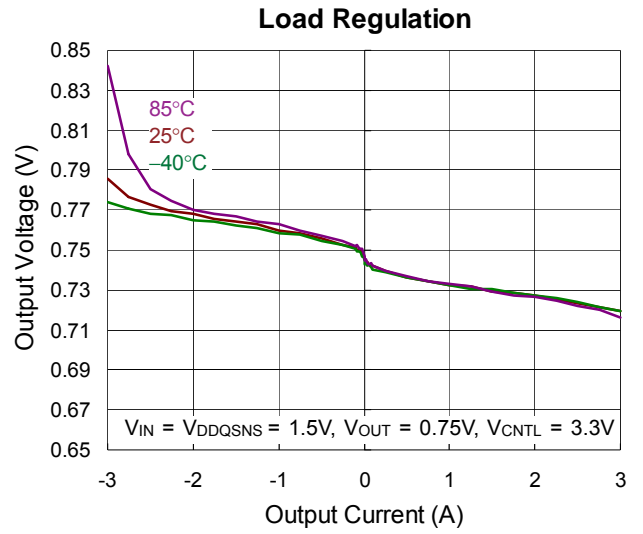
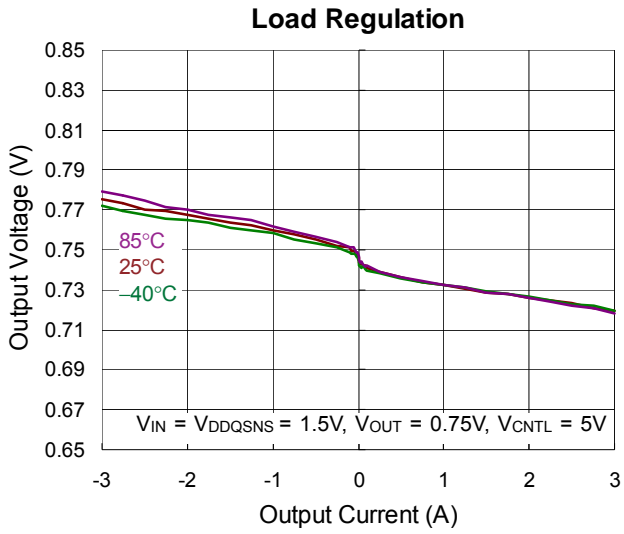

Output Voltage vs. Temperature

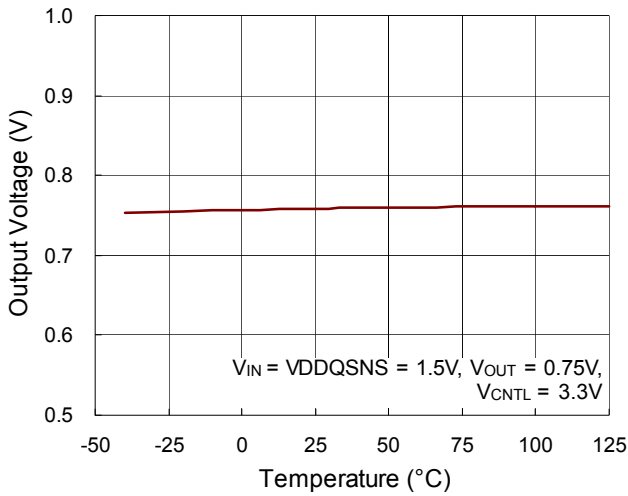

REFOUT Voltage vs. Temperature

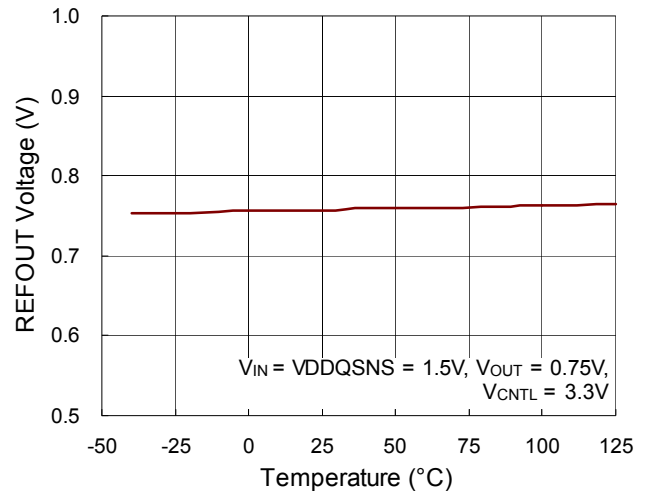

VCNTL Supply Current vs. Temperature

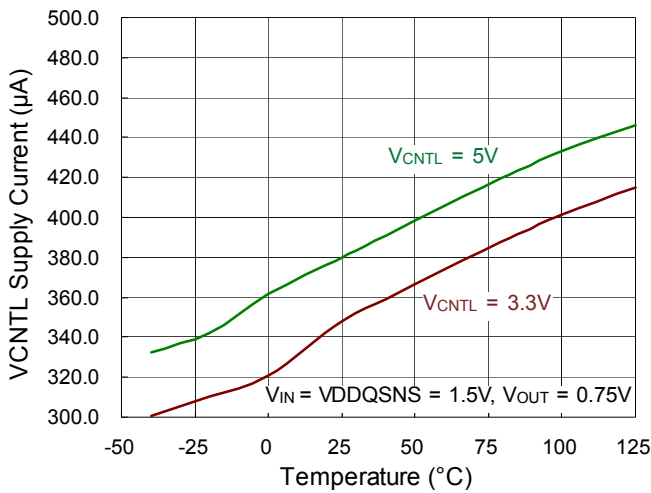

VCNTL Shutdown Current vs. Temperature

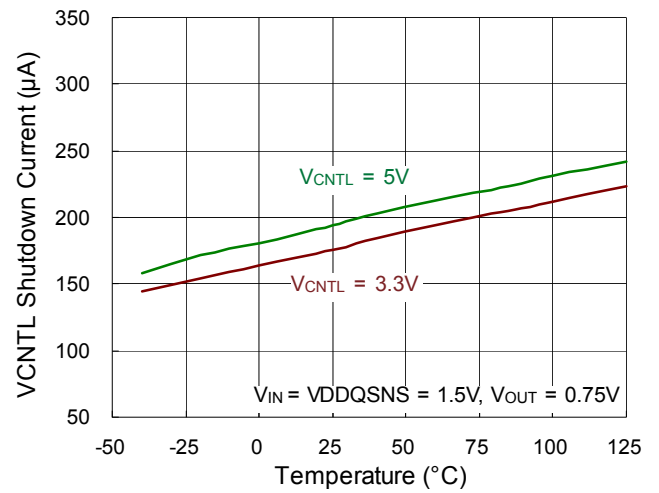

UVLO vs. Temperature

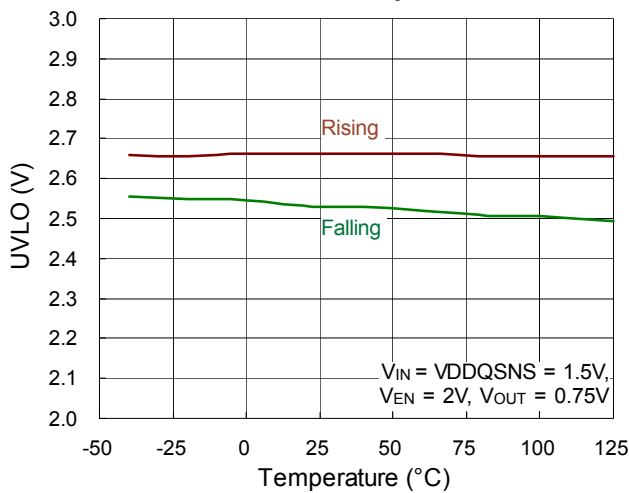

Sourcing Current Limit vs. Temperature

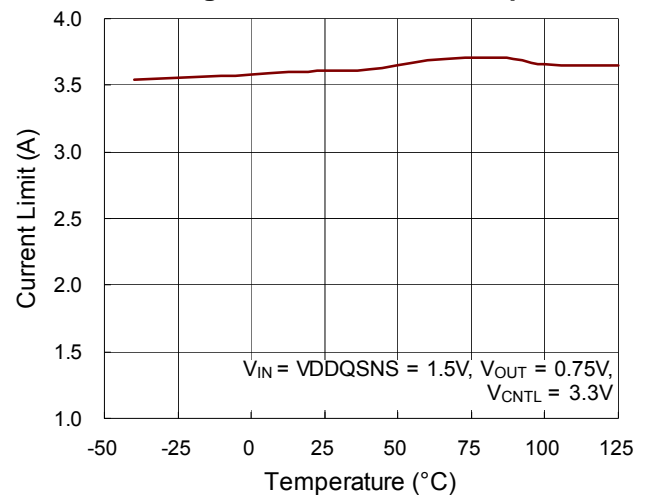

Sinking Current Limit vs. Temperature

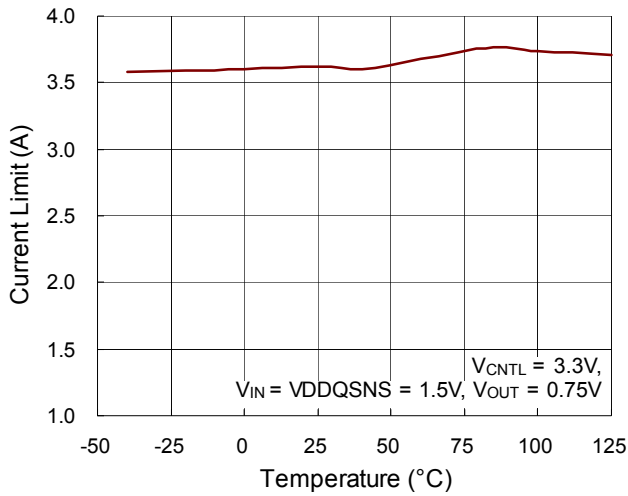

Power On from EN

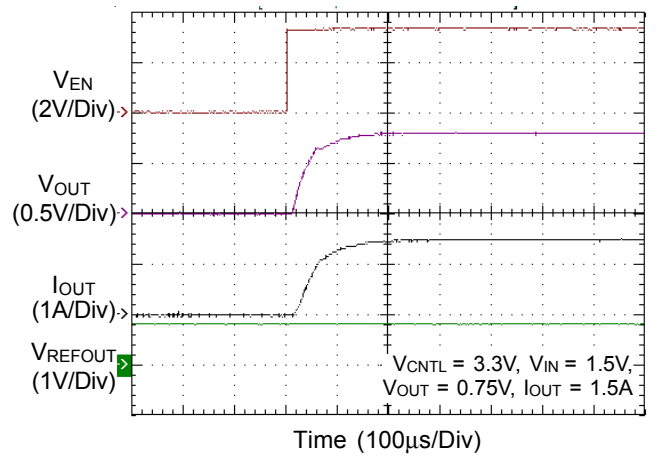

Power Off from EN

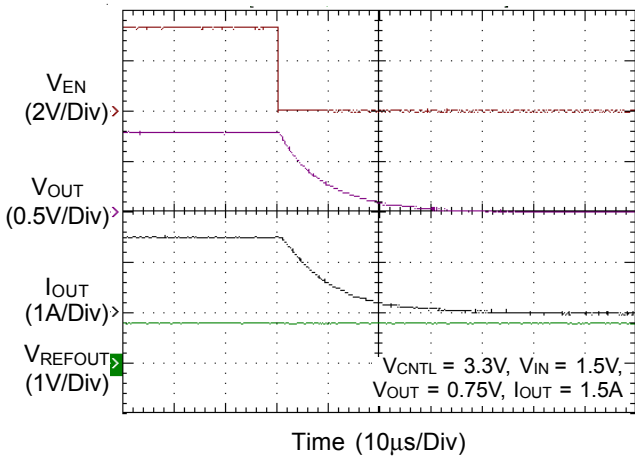

0.75V_{OUT} @ 1.5A Transient Response

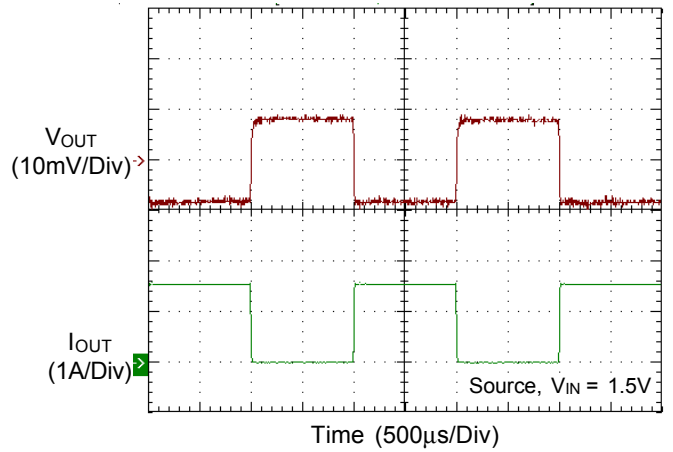

0.75V_{OUT} @ 1.5A Transient Response

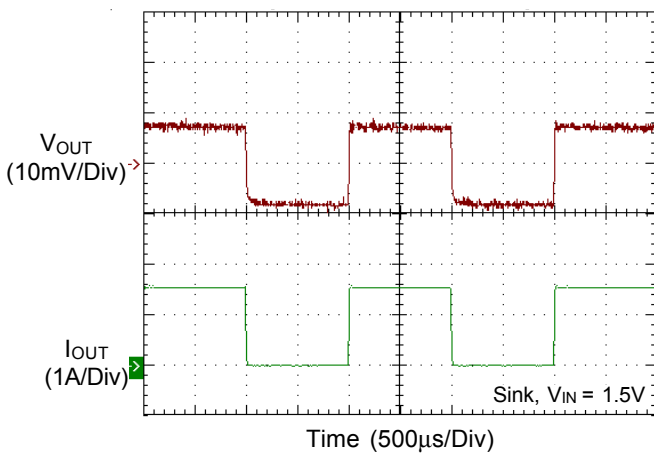

Application Information

The RT2568 is a 3.5A sink/source tracking termination regulator. It is specifically designed for low-cost and low-external component count system such as notebook PC applications. The RT2568 possesses a high speed operating amplifier that provides fast load transient response and only requires two 10μF ceramic input capacitors and three 10μF ceramic output capacitors.

Capacitor Selection

Good bypassing is recommended from VLDOIN to GND to help improve AC performance. A 10μF or greater input capacitor located as close as possible to the IC is recommended. The input capacitor must be located at a distance of less than 0.5 inches from the VLDOIN pin of the IC.

Adding a 1μF ceramic capacitor close to the VIN pin and it should be kept away from any parasitic impedance from the supply power. For stable operation, the total capacitance of the ceramic capacitor at the VTT output terminal must be larger than 30μF. The RT2568 is designed specifically to work with low ESR ceramic output capacitor in space saving and performance consideration. Larger output capacitance can reduce the noise and improve load transient response, stability and PSRR. The output capacitor should be located near the VTT output terminal pin as close as possible.

Thermal Considerations

For continuous operation, do not exceed absolute maximum junction temperature. The maximum power dissipation depends on the thermal resistance of the IC package, PCB layout, rate of surrounding airflow, and difference between junction and ambient temperature. The maximum power dissipation can be calculated by the following formula :

$$P_{D(MAX)} = (T_{J(MAX)} - T_A) / \theta_{JA}$$

where $T_{J(MAX)}$ is the maximum junction temperature, T_A is the ambient temperature, and θ_{JA} is the junction to ambient thermal resistance.

For recommended operating condition specifications, the maximum junction temperature is 125°C. The junction to ambient thermal resistance, θ_{JA} , is layout dependent. For

WDFN-10L 3x3 package, the thermal resistance, θ_{JA} , is 40°C/W on a standard JEDEC 51-7 four-layer thermal test board. The maximum power dissipation at $T_A = 25^\circ\text{C}$ can be calculated by the following formula :

$$P_{D(MAX)} = (125^\circ\text{C} - 25^\circ\text{C}) / (40^\circ\text{C/W}) = 2.5\text{W for WDFN-10L 3x3 package}$$

The maximum power dissipation depends on the operating ambient temperature for fixed $T_{J(MAX)}$ and thermal resistance, θ_{JA} . The derating curve in Figure 1 allows the designer to see the effect of rising ambient temperature on the maximum power dissipation.

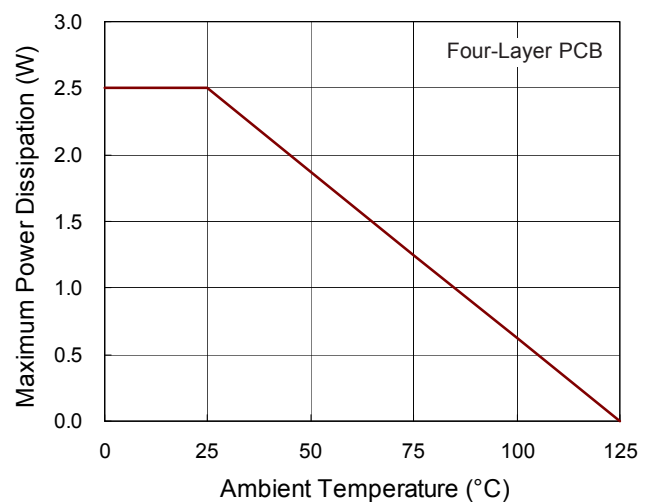

Figure 1. Derating Curve of Maximum Power Dissipation

Layout Considerations

For best performance of the RT2568, the PCB layout suggestions below are highly recommend :

- ▶ With wide and short connection plane between capacitors and pins for trace impedance minimization.
- ▶ The ground plane connected by a wide copper surface for good thermal dissipation, add via connection also helps reduce the GND loop trace.
- ▶ Connect the SENSE pin to the positive node of output capacitor at V_{OUT} terminal for output target level remote sensing.

- ▶ Since the output voltage V_{OUT} setting is follow the REFIN pin input voltage level V_{REFIN} ($V_{OUT} = V_{REFIN}$), the REFIN pin can connected with independent voltage source for stable input signal and good V_{OUT} target accuracy. For the application which V_{REFIN} sinks the voltage source divided from V_{IN} power trace, with separate connection trace between R1 and V_{IN} terminal side for good V_{REFIN} signal stability also avoid the reference voltage level shrink down caused by V_{IN} trace loss at high load operation.

Figure 2 shows an example for the layout reference that reduce conduction trace loop, helping inductive parasitic minimize, load transient reduction and good circuit stability.

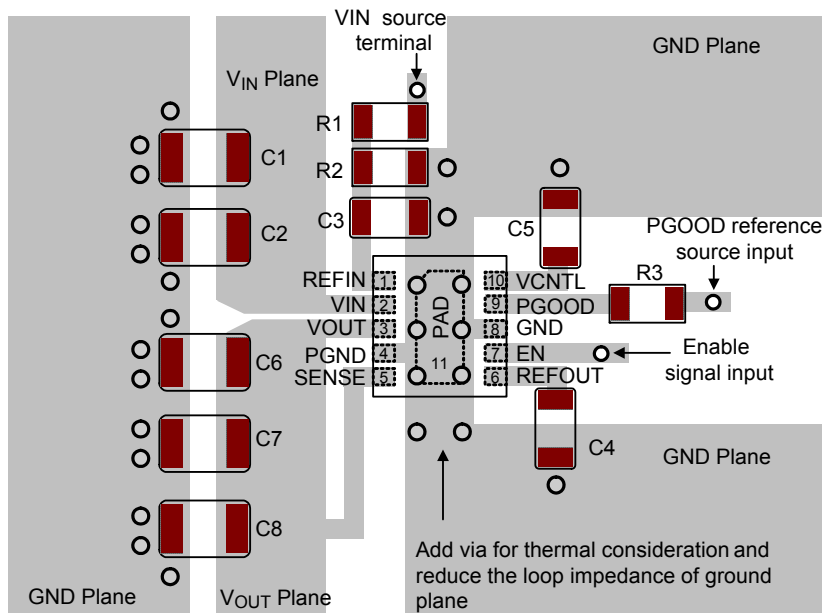
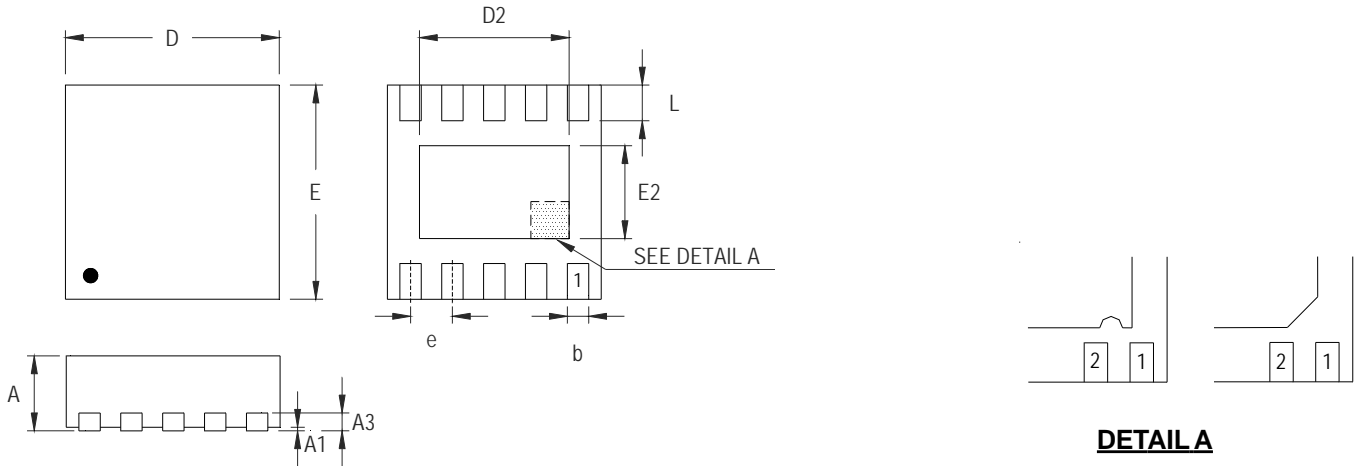

Figure 2. PCB Layout Guide

Outline Dimension



DETAIL A

Pin #1 ID and Tie Bar Mark Options

Note : The configuration of the Pin #1 identifier is optional, but must be located within the zone indicated.

Symbol	Dimensions In Millimeters		Dimensions In Inches	
	Min	Max	Min	Max
A	0.700	0.800	0.028	0.031
A1	0.000	0.050	0.000	0.002
A3	0.175	0.250	0.007	0.010
b	0.180	0.300	0.007	0.012
D	2.950	3.050	0.116	0.120
D2	2.300	2.650	0.091	0.104
E	2.950	3.050	0.116	0.120
E2	1.500	1.750	0.059	0.069
e	0.500		0.020	
L	0.350	0.450	0.014	0.018

W-Type 10L DFN 3x3 Package

Richtek Technology Corporation

14F, No. 8, Tai Yuen 1st Street, Chupei City
 Hsinchu, Taiwan, R.O.C.
 Tel: (8863)5526789

Richtek products are sold by description only. Richtek reserves the right to change the circuitry and/or specifications without notice at any time. Customers should obtain the latest relevant information and data sheets before placing orders and should verify that such information is current and complete. Richtek cannot assume responsibility for use of any circuitry other than circuitry entirely embodied in a Richtek product. Information furnished by Richtek is believed to be accurate and reliable. However, no responsibility is assumed by Richtek or its subsidiaries for its use; nor for any infringements of patents or other rights of third parties which may result from its use. No license is granted by implication or otherwise under any patent or patent rights of Richtek or its subsidiaries.

单击下面可查看定价，库存，交付和生命周期等信息

[>>Richtek\(台湾立锜\)](#)