

# Charging Port Controller and Integrated 36V 3A Synchronous Buck Converter

## General Description

The RTQ2117A combines a charging port controller, USB 2.0 high-speed data line (D+/D-) switch and a 3A synchronous buck converter.

The RTQ2117A provides the electrical signatures on D+/D- to support charging schemes compatible with the USB 2.0 Battery Charging Specification BC1.2 and Chinese Telecommunication Industry Standard YD/T 1591-2009. Auto-detect mode is also integrated which supports USB 2.0 Battery Charging Specification BC1.2 Dedicated Charging Port (DCP), Divider 3 mode and 1.2V shorted mode to comply with the legacy fast charging mode of mobile devices.

The RTQ2117A integrates a high efficiency, monolithic synchronous buck converter that can deliver up to 3A output current from a 3V to 36V wide range input supply and is protected from load-dump transients up to 42V.

The RTQ2117A has constant current control to achieve adjustable USB current limit and implement the current sense signal for adjustable USB power output voltage with load line compensation. The converter includes optional spread-spectrum frequency modulation to overcome EMI issue and complete protection for safe and smooth operation in all applied conditions. Protection features include cycle-by-cycle current limit for protection against shorted outputs, soft-start control to eliminate input current surge during start-up, input under-voltage lockout, output under-voltage protection, output over-voltage protection and over-temperature protection. The RTQ2117A can be used to support Type-A connector.

The RTQ2117A is fully specified over the temperature range of  $T_J = -40^{\circ}\text{C}$  to  $125^{\circ}\text{C}$  and available in WETD-VQFN-32L 5x5.

## Features

- CDP/SDP Mode per USB BC1.2
- USB Charging Port Controller
  - ▶ Automatic DCP Modes
    - ◆ DCP Shorted Mode and YD/T 1591-2009
    - ◆ 2.7V Divider 3 Mode
    - ◆ 1.2V Mode
- High Bandwidth 1.2GHz Data Switches
- Support Mode Change Among SDP/CDP/DCP Auto
- Keep Data Communication During Worse Cold Crank Situation at 3V
- 36V 3A Synchronous Buck Converter
  - ▶ 3V to 36V Input Voltage Range
  - ▶ 3A Continuous Output Current
  - ▶ CC/CV Mode Control
  - ▶ Adjustable and Synchronizable Switching Frequency : 300kHz to 2.2MHz
  - ▶ Selectable PSM/PWM at Light Load
  - ▶ Adjustable Soft-Start
  - ▶ Adjustable USB Power Output Voltage between 5V and 6V with Load Line Compensation
  - ▶ Optional Spread-Spectrum Frequency Modulation for EMI Reduction
- Protection Function
  - ▶ DS+/DS- OVP
  - ▶ Over-Temperature Protection
  - ▶ Cycle-by-Cycle Over-Current Limit Protection
  - ▶ Input Under-Voltage Protection
  - ▶ VBUS Over-Voltage Protection
  - ▶ Adjacent Pin-Short Protection
- Power Good Indicator
- Enable Control
- HBM 8kV on DS+/DS- Pins
- Wettable Flank Package
- AEC-Q100 Grade 1 Qualified

## Applications

- Automotive Car Chargers
- USB Power Chargers

## Ordering Information

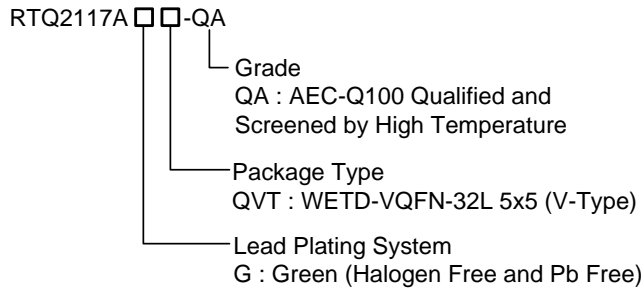

## Marking Information

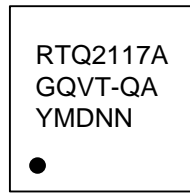

RTQ2117AGQVT : Product Number  
 QA : Automotive Product Grade  
 YMDNN : Date Code

Note :

Richtek products are :

- ▶ RoHS compliant and compatible with the current requirements of IPC/JEDEC J-STD-020.
- ▶ Suitable for use in SnPb or Pb-free soldering processes.

## Pin Configuration

(TOP VIEW)

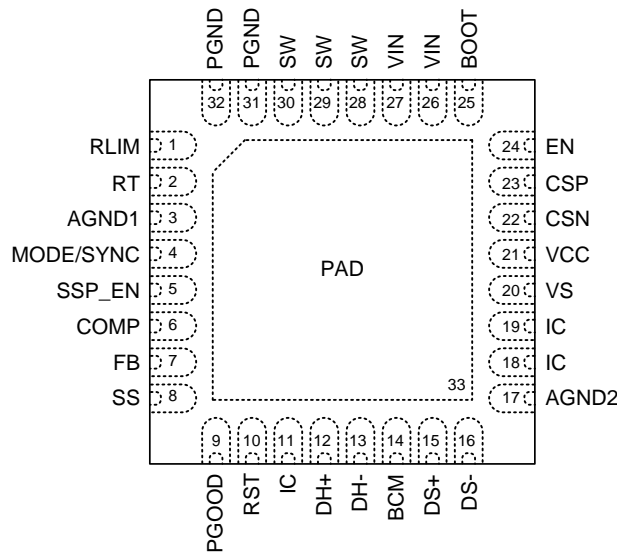

WETD-VQFN-32L 5x5

**Functional Pin Description**

Pin No.	Pin Name	Pin Function
1	RLIM	Current limit setup pin. Connect a resistor from this pin to ground to set the current limit value. The recommended resistor value is ranging from 33kΩ (for typ. 5.5A) to 91kΩ (for typ. 2.3A).
2	RT	Oscillator frequency setup pin. Connect a resistor from this pin to ground to set the switching frequency. The recommended resistor value is ranging from 174kΩ (for typ. 300kHz) to 21kΩ (for typ. 2.2MHz).
3	AGND1	Analog ground 1.
4	MODE/SYNC	Mode selection and external synchronous signal input. Ground this pin or leave this pin floating enables the power saving mode operation at light load. Apply a DC voltage of 2V or higher or tie to VCC for FPWM mode operation. Tie to a clock source for synchronization to an external frequency.
5	SSP_EN	Spread spectrum enable input. Connect this pin to VCC to enable spread spectrum. Float this pin or connect it to Ground to disable spread spectrum.
6	COMP	Compensation node. Connect external compensation elements to this pin to stabilize the control loop.
7	FB	Feedback voltage input. Connect this pin to the midpoint of the external feedback resistive divider to set the output voltage of the converter to the desired regulation level. The RTQ2117A regulates the FB voltage at a feedback reference voltage, typically 0.8V.
8	SS	Soft-start capacitor connection node. Connect an external capacitor between this pin and ground to set the soft-start time.
9	PGOOD	Open-drain power-good indication output. The power-good function is activated after soft-start is finished. "Do Not" leave this pin floating and must be connected this pin to VCC through a resistor. PGOOD is pulled high when both $V_{OUT} > 90\%$ and $V_{SS} > 2V$ (typically). PG is pulled low when $V_{OUT} < 85\%$ , $V_{OUT} > 120\%$ and OTP.
10	RST	Open drain logic output for battery charging mode change output discharge. This pin must be directly connected to SS pin.
11, 18, 19	IC	Internal connection.
12	DH+	D+ data line to USB host controller.
13	DH-	D- data line to USB host controller.
14	BCM	Battery charging mode control pin : high→CDP, low→SDP, floating→DCP_Auto.
15	DS+	D+ data line to upstream connector.
16	DS-	D- data line to upstream connector.
17	AGND2	Analog ground 2.
20	VS	VBUS sensing, connected to VBUS through 200Ω external resistor.
21	VCC	Linear regulator output. VCC is the output of the internal 5V linear regulator powered by VIN. Decouple with a 1μF, X7R ceramic capacitor from VCC to ground for normal operation.
22	CSN	Current sense negative input. Do not float this pin.
23	CSP	Current sense positive input. Do not float this pin.
24	EN	Enable control input. A logic-high enables the converter; a logic-low forces the RTQ2117A into shutdown mode.

Pin No.	Pin Name	Pin Function
25	BOOT	Bootstrap capacitor connection node to supply the high-side gate driver. Connect a 0.1μF, X7R ceramic capacitor between this pin and SW pin.
26, 27	VIN	Power input. The input voltage range is from 3V to 36V after soft-start is finished. Connect input capacitors between this pin and PGND. It is recommended to use a 4.7μF, X7R and a 0.1μF, X7R capacitors.
28, 29, 30	SW	Switch node. SW is the switching node that supplies power to the output and connect the output LC filter from SW to the output load.
31, 32	PGND	Power ground.
33 Exposed pad)	PAD	Exposed pad. The exposed pad is internally unconnected and must be soldered to a large PGND plane. Connect this PGND plane to other layers with thermal vias to help dissipate heat from the RTQ2117A.

Functional Block Diagram

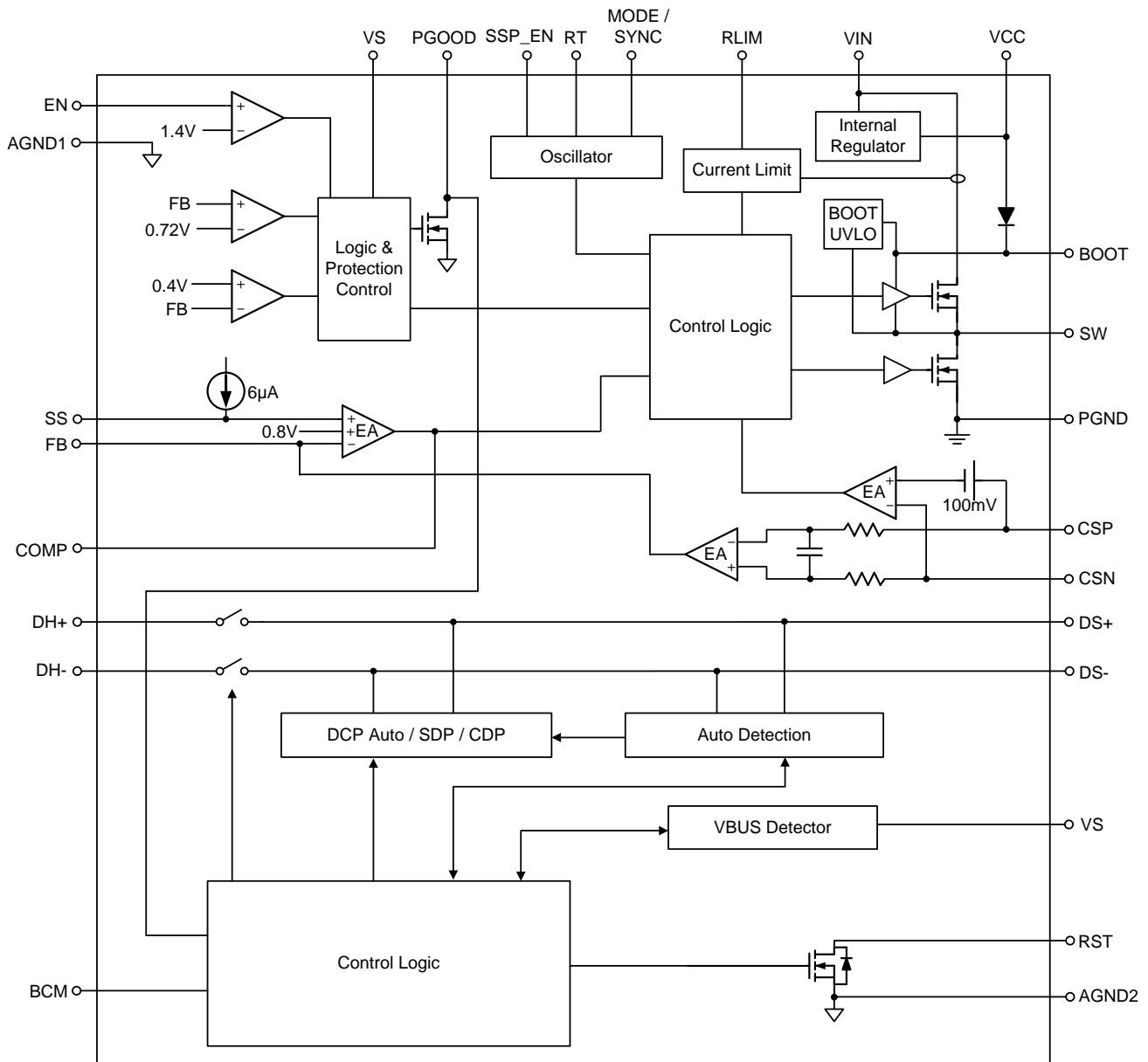

**Operation**

The RTQ2117A combines charging port controller, USB 2.0 high-speed data line (D+/D-) switch and a 3A synchronous buck converter.

The RTQ2117A integrates 70mΩ high-side and 70mΩ low-side MOSFETs to achieve high efficiency conversion. The current mode control architecture supports fast transient response with simple compensation.

The RTQ2117A supports the common USB charging schemes: USB Battery Charging Specification BC1.2, Chinese Telecommunications Industry Standard YD/T 1591-2009, Divider 3 Mode and 1.2V Short Mode. Pass through operation for USB Hi-Speed (480Mbps) and USB Full-Speed (12Mbps) is also supported.

**Main Control Loop (CV Regulation)**

The RTQ2117A includes a high efficiency step down converter utilizes the peak current mode control. An internal oscillator initiates turn-on of the high-side MOSFET switch. At the beginning of each clock cycle, the internal high-side MOSFET switch turns on, allowing current to ramp up in the inductor. The inductor current is internally monitored during each switching cycle. The output voltage is sensed on the FB pin via the resistor divider, R1 and R2, and compared with the internal reference voltage for constant voltage control ( $V_{REF\_CV}$ ) to generate a CV compensation signal ( $V_{COMP}$ ) on the COMP pin. A control signal derived from the inductor current is compared to the voltage at the COMP pin, derived from the feedback voltage. When the inductor current reaches its threshold, the high-side MOSFET switch is turned off and inductor current ramps-down. While the high-side switch is off, inductor current is supplied through the low-side MOSFET switch. This cycle repeats at the next clock cycle. In this way, duty-cycle and output voltage are controlled by regulating inductor current.

**Constant Current (CC) Regulation**

The RTQ2117A offers average current control loop also. The control loop behavior is basically the same as the peak current mode in constant voltage regulation. The difference is the COMP will be also governed by the output of the internal current error amplifier when

FB voltage is below the regulation target. The output current control is obtained by sensing the voltage drop across an external sense resistor ( $R_{SENSE}$ ) between CSP and CSN, as shown in Figure 1. The internal reference voltage for the current error amplifier is  $V_{REF\_CC}$  (100mV, typically). If the output current increase and the current sense voltage ( $V_{CS}$ , i.e.  $V_{CSP} - V_{CSN}$ ) is equal to  $V_{REF\_CC}$ , the current error amplifier output will clamp the COMP lower to achieve average current control and vice versa. Once the output current decrease and current sense voltage is less than 100mV, the CV loop dominates the COMP again and the output voltage goes back to the regulation voltage determined by resistor divider from the output to the FB pin and ground accordingly.

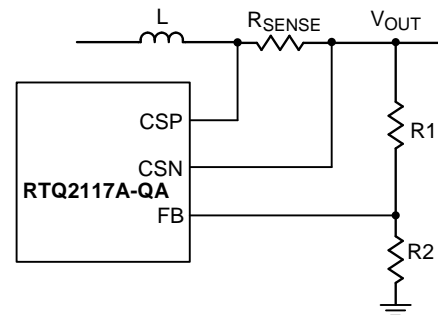

Figure 1. Average Current Setting

**MODE Selection and Synchronization**

The RTQ2117A provides an MODE/SYNC pin for Forced-PWM Mode (FPWM) and Power Saving Mode (PSM) operation selection at light load. If  $V_{MODE/SYNC}$  rises above a logic-high threshold voltage ( $V_{IH\_SYNC}$ ) of the MODE/SYNC input, the RTQ2117A is locked in FPWM. If  $V_{MODE/SYNC}$  is held below a logic-low threshold voltage ( $V_{IL\_SYNC}$ ) of the MODE/SYNC input, the RTQ2117A operates in PSM at light load to improve efficiency. The RTQ2117A can also be synchronized with an external clock ranging from 300kHz to 2.2MHz by MODE/SYNC pin.

**Forced-PWM Mode**

Forced-PWM operation provides constant frequency operation at all loads and is useful in applications sensitive to switching frequency. This mode trades off reduced light load efficiency for low output voltage

ripple, tight output voltage regulation, and constant switching frequency. In this mode, a negative current limit of  $I_{SK\_L}$  is imposed to prevent damage to the low-side MOSFET switch of the regulator. "Do Not" connect external voltage source to output terminal in FPWM, which may boost  $V_{IN}$ . The converter synchronizes to any valid clock signal on the SYNC input when in FPWM.

When constant frequency operation is more important than light load efficiency, pull the MODE/SYNC input high or provide a valid synchronization input. Once activated, this feature ensures that the switching frequency stays away from the AM frequency band, while operating between the minimum and maximum duty cycle limits.

### Power Saving Mode

With the MODE/SYNC pin floating or pull low, that is, with a logic low on the MODE/SYNC input, the RTQ2117A operates in power saving mode (PSM) at light load to improve light load efficiency. In PSM, IC starts to switch when  $V_{FB}$  is lower than PSM threshold ( $V_{REF\_CV} \times 1.005$ , typically) and stops switching when  $V_{FB}$  is high enough. IC detects the peak inductor current ( $I_{L\_PEAK}$ ) and keeps high-side MOSFET switch on until the  $I_L$  reaches its minimum peak current level (1A at  $V_{IN} = 12V$ , typically) to ensure that IC can provide sufficiency output current with each switching pulse. Zero-current detection is also activated to prevent that  $I_L$  becomes negative and to ensure no external discharging current from the output capacitor. During non-switching period, most of the internal circuit is shut down, and the supply current drops to quiescent current to reduce the quiescent power consumption. With lower output loading, the non-switching period is longer, so the effective switching frequency becomes lower to reduce the switching loss and switch driving loss.

### Maximum Duty Cycle Operation

The RTQ2117A is designed to operate in dropout at the high duty cycle approaching 100%. If the operational duty cycle is large and the required off time becomes smaller than minimum off time, the RTQ2117A starts to enable skip off time function and

keeps high-side MOSFET switch on continuously. The RTQ2117A implements skip off time function to achieve high duty approaching 100%. Therefore, the maximum output voltage is near the minimum input supply voltage of the application. The input voltage at which the RTQ2117A enter dropout changes depending on the input voltage, output voltage, switching frequency, load current, and the efficiency of the design.

### BOOT UVLO

The BOOT UVLO circuit is implemented to ensure a sufficient voltage of bootstrap capacitor for turning on the high-side MOSFET switch at any condition. The BOOT UVLO usually activates at extremely high conversion ratio or the higher VOUT application operates at very light load. With such conditions, the low-side MOSFET switch may not have sufficient turn-on time to charge the bootstrap capacitor. The RTQ2117A monitors voltage of bootstrap capacitor and force to turn on the low-side MOSFET switch when the voltage of bootstrap capacitor falls below  $V_{BOOT\_UVLO\_L}$  (typically, 2.3V). Meanwhile, the minimum off time is extended to 150ns (typically) hence prolong the bootstrap capacitor charging time. The BOOT UVLO is sustained until the  $V_{BOOT-SW}$  is higher than  $V_{BOOT\_UVLO\_H}$  (typically, 2.4V).

### Internal Regulator

The RTQ2117A integrates a 5V linear regulator ( $V_{CC}$ ) that is supplied by  $V_{IN}$  and provides power to the internal circuitry. The internal regulator operates in low dropout mode when  $V_{IN}$  is below 5V. The  $V_{CC}$  can be used as the PGOOD pull-up supply but it is "NOT" allowed to power other device or circuitry. The  $V_{CC}$  pin must be bypassed to ground with a minimum value of effective  $V_{CC}$  capacitance is 0.7 $\mu$ F. In many applications, a 1 $\mu$ F, X7R is recommended and it needs to be placed as close as possible to the  $V_{CC}$  pin. Be careful to account for the voltage coefficient of ceramic capacitors when choosing the value and case size. Many ceramic capacitors lose 50% or more of their rated value when used near their rated voltage.

**Enable Control**

The RTQ2117A provides an EN pin, as an external chip enable control, to enable or disable the RTQ2117A. If  $V_{EN}$  is held below a logic-low threshold voltage ( $V_{ENL}$ ) of the enable input (EN), switching is inhibited even if the  $V_{IN}$  voltage is above  $V_{IN}$  under-voltage lockout threshold ( $V_{UVLOH}$ ). If  $V_{EN}$  is held below 0.4V, the converter will enter into shutdown mode, that is, the converter is disabled. During shutdown mode, the supply current can be reduced to  $I_{SHDN}$  ( $5\mu A$  or below). If the EN voltage rises above the logic-high threshold voltage ( $V_{ENH}$ ) while the  $V_{IN}$  voltage is higher than  $V_{UVLO}$ , the RTQ2117A will be turned on, that is, switching being enabled and soft-start sequence being initiated. The current source of EN typically sinks  $1.2\mu A$ .

**Soft-Start**

The soft-start function is used to prevent large inrush currents while the converter is being powered up. The RTQ2117A provides an SS pin so that the soft-start time can be programmed by selecting the value of the external soft-start capacitor  $C_{SS}$  connected from the SS pin to ground. During the start-up sequence, the soft-start capacitor is charged by an internal current source  $I_{SS}$  (typically,  $6\mu A$ ) to generate a soft-start ramp voltage as a reference voltage to the PWM comparator. If the output is for some reasons pre-biased to a certain voltage during start-up, the RTQ2117A will not turn on high-side MOSFET switch until the voltage difference between SS pin and FB pin is larger than 400mV (typically). And only when this ramp voltage is higher than the feedback voltage  $V_{FB}$ , the switching will be resumed. The output voltage can then ramp up smoothly to its targeted regulation voltage, and the converter can have a monotonic smooth start-up. For soft-start control, the SS pin should never be left unconnected. After the SS pin voltage rises above 2V (typically), the PGOOD pin will be in high impedance and  $V_{PGOOD}$  will be held high. The typical start-up waveform shown in Figure 2 indicate the sequence and timing between the output voltage and related voltage.

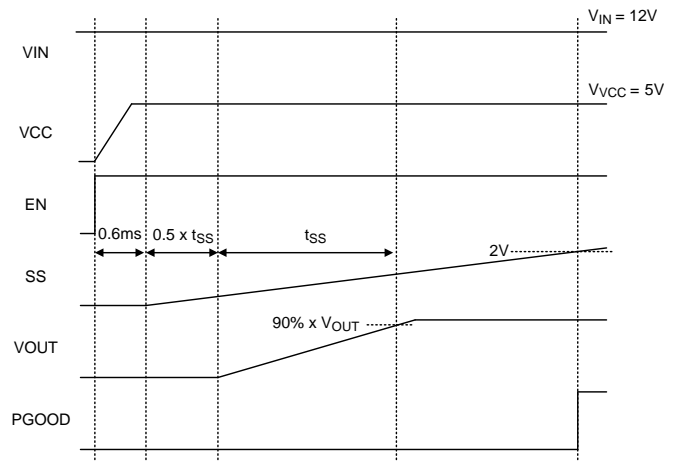

Figure 2. Start-Up Sequence

**Power Good Indication**

The RTQ2117A features an open-drain power-good output (PGOOD) to monitor the output voltage status. The output delay of comparator prevents false flag operation for short excursions in the output voltage, such as during line and load transients. Pull-up PGOOD with a resistor to  $V_{CC}$  or an external voltage below 5.5V. The power-good function is activated after soft start is finished and is controlled by a comparator connected to the feedback signal  $V_{FB}$ . If  $V_{FB}$  rises above a power-good high threshold ( $V_{TH\_PGLH1}$ ) (typically 90% of the reference voltage), the PGOOD pin will be in high impedance and  $V_{PGOOD}$  will be held high after a certain delay elapsed. When  $V_{FB}$  exceeds  $V_{TH\_PGLH1}$  (typically 120% of the reference voltage), the PGOOD pin will be pulled low, moreover, IC turns off high-side MOSFET switch and turns on low-side MOSFET switch until the inductor current reaches  $I_{SK\_L}$  if MODE pin is set high. If the  $V_{FB}$  is still higher than  $V_{TH\_PGLH1}$ , the converter enters low-side MOSFET switch sinking current limit operation. If MODE pin is set low, IC turns off low-side MOSFET switch once the inductor current reaches zero current unless  $V_{BOOT\_SW}$  is too low. For  $V_{FB}$  higher than  $V_{TH\_PGLH1}$ ,  $V_{PGOOD}$  can be pulled high again if  $V_{FB}$  drops back by a power-good high threshold ( $V_{TH\_PGLH2}$ ) (typically 117% of the reference voltage). When  $V_{FB}$  fall short of power-good low threshold ( $V_{TH\_PGLL2}$ ) (typically 85% of the reference voltage), the PGOOD pin will be pulled low. Once being started-up, if any internal protection is triggered, PGOOD will be pulled low to GND. The internal

open-drain go low impedance ( $10\Omega$ , typically) and will pull the PGOOD pin low.

The power good indication profile is shown in Figure 3.

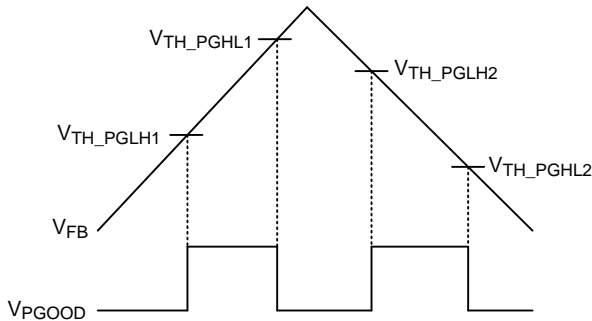

Figure 3. The Logic of PGOOD

### Spread-Spectrum Operation

Due to the periodicity of the switching signals, the energy concentrates in one particular frequency and also in its harmonics. These levels of energy is radiated and therefore this is where a potential EMI issue arises. The RTQ2117A have optional spread-spectrum function and SSP\_EN pin can be programmed to turn on/off the spread spectrum, further simplifying compliance with the CISPR and automotive EMI requirements. The spread spectrum can be active when soft-start is finished and zero-current is not detected. If  $V_{SSP\_EN}$  rises above a logic-high threshold voltage (2V, typically) of the SSP\_EN input, the RTQ2117A enable spread spectrum operation. The spread-spectrum is implemented by a pseudo random sequence and uses +6% spread of the switching frequency. For example, when the RTQ2117A is programmed to 2.1MHz, the frequency will vary from 2.1MHz to 2.226MHz. Therefore, the RTQ2117A still guarantees that the 2.1MHz switching frequency setting does not drop into the AM band limit of 1.8MHz. However, the spread spectrum can't be active when the RTQ2117A is synchronized with an external clock by MODE/SYNC pin.

### Input Under-Voltage Lockout

In addition to the EN pin, the RTQ2117A also provides enable control through the VIN pin. If  $V_{EN}$  rises above  $V_{ENH}$  first, switching will still be inhibited until the VIN voltage rises above  $V_{UVLO}$ . It is to ensure that the internal regulator is ready so that operation with

not-fully-enhanced internal MOSFET switches can be prevented. After the RTQ2117A is powered up, if the input voltage  $V_{IN}$  goes below the UVLO falling threshold voltage ( $V_{UVLOL}$ ), this switching will be inhibited; if  $V_{IN}$  rises above the UVLO rising threshold ( $V_{UVLOH}$ ), the RTQ2117A will resume switching. Note that  $V_{IN} = 3V$  is only design for cold crank requirement, normal input voltage should be larger than UVLO threshold to turn on.

### High-Side Switch Peak Current Limit Protection

The RTQ2117A includes a cycle-by-cycle high-side switch peak current-limit protection against the condition that the inductor current increasing abnormally, even over the inductor saturation current rating. The high-side MOSFET switch peak current limit of the RTQ2117A is adjustable by placing a resistor on the RLIM pin. The recommended resistor value is ranging from  $33k\Omega$  (for typ. 5.5A) to  $91k\Omega$  (for typ. 2.2A) and it is recommended to use 1% tolerance or better and temperature coefficient of 100 ppm or less resistors. The inductor current through the high-side MOSFET switch will be measured after a certain amount of delay when the high-side MOSFET switch being turned on. If an over-current condition occurs, the converter will immediately turn off the high-side MOSFET switch and turn on the low-side MOSFET switch to prevent the inductor current exceeding the high-side MOSFET switch peak current limit ( $I_{LIM\_H}$ ).

### Low-Side Switch Current-Limit Protection

The RTQ2117A not only implements the high-side switch peak current limit but also provides the sourcing current limit and sinking current limit for low-side MOSFET switch. With these current protections, the IC can easily control inductor current at both side switch and avoid current runaway for short-circuit condition.

For the low-side MOSFET switch sourcing current limit, there is a specific comparator in internal circuitry to compare the low-side MOSFET switch sourcing current to the low-side MOSFET switch sourcing current limit at the end of every clock cycle. When the low-side MOSFET switch sourcing current is higher than the low-side MOSFET switch sourcing current limit which is high-side MOSFET switch current limit ( $I_{LIM\_H}$ )



multiplied by 0.95, the new switching cycle is not initiated until inductor current drops below the low-side MOSFET switch sourcing current limit.

For the low-side MOSFET switch sinking current limit protection, it is implemented by detecting the voltage across the low-side MOSFET switch. If the low-side switch sinking current exceeds the low-side MOSFET switch sinking current limit ( $I_{SK\_L}$ ) (typically, 2A), the converter will immediately turn off the low-side MOSFET switch and turn on the high-side MOSFET switch. "Do Not" choose too small inductance, which may trigger the low-side MOSFET switch sinking current limit protection.

**Output Under-Voltage Protection**

The RTQ2117A includes output under-voltage protection (UVP) against over-load or short-circuited condition by constantly monitoring the feedback voltage  $V_{FB}$ . If  $V_{FB}$  drops below the under-voltage protection trip threshold (typically 50% of the internal reference voltage), the UV comparator will go high to turn off the high-side MOSFET and then turn off the low-side MOSFET when the inductor current drop to zero. If the output under-voltage condition continues for a period of time, the RTQ2117A enters output under-voltage protection with hiccup mode and discharges the  $C_{SS}$  by an internal discharging current source  $I_{SS\_DIS}$  (typically, 80nA). During hiccup mode, the RTQ2117A remains shut down. After the  $V_{SS}$  is discharged to less than 150mV (typically), the RTQ2117A attempts to re-start up again, the internal charging current source  $I_{SS}$  gradually increases the voltage on  $C_{SS}$ . The high-side MOSFET switch will start switching when voltage difference between SS pin and FB pin is larger than 400mV (i.e.  $V_{SS} - V_{FB} > 400mV$ , typically). If the output under-voltage condition is not removed, the high-side MOSFET switch stop switching when the voltage difference between SS pin and FB pin is 700mV ( i.e.  $V_{SS} - V_{FB} = 700mV$ , typically) and then the  $I_{SS\_DIS}$  discharging current source begins to discharge  $C_{SS}$ .

Upon completion of the soft-start sequence, if the output under-voltage condition is removed, the converter will resume normal operation; otherwise, such cycle for auto-recovery will be repeated until the output under-voltage condition is cleared.

Hiccup mode allows the circuit to operate safely with low input current and power dissipation, and then resume normal operation as soon as the over-load or short-circuit condition is removed. A short circuit protection and recovery profile is shown in Figure 4.

Since the  $C_{SS}$  will be discharged to 150mV when the RTQ2117A enters output under-voltage protection, the first discharging time ( $t_{SS\_DIS1}$ ) can be calculated as follow

$$t_{SS\_DIS1} = C_{SS} \times \frac{V_{SS} - 0.15}{I_{SS\_DIS}}$$

The equation below assumes that the  $V_{FB}$  will be 0 at short-circuited condition and it can be used to calculate the  $C_{SS}$  discharging time ( $t_{SS\_DIS2}$ ) and charging time ( $t_{SS\_CH}$ ) during hiccup mode.

$$t_{SS\_DIS2} = C_{SS} \times \frac{0.55}{I_{SS\_DIS}}$$

$$t_{SS\_CH} = C_{SS} \times \frac{0.55}{I_{SS\_CH}}$$

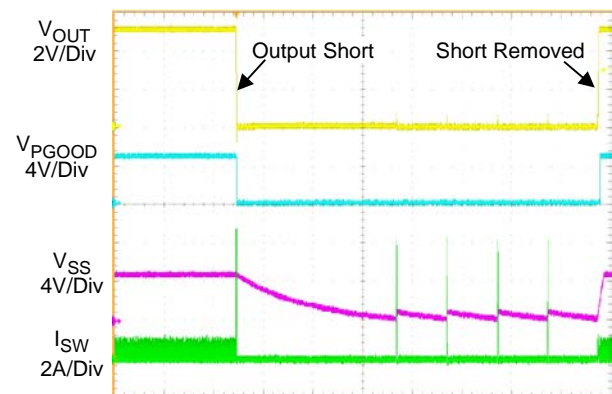

Figure 4. Short Circuit Protection and Recovery

**Over-Temperature Protection**

The RTQ2117A includes an over temperature protection (OTP) circuitry to prevent overheating due to excessive power dissipation. The OTP will shut down switching operation when junction temperature exceeds a thermal shutdown threshold  $T_{SD}$ . Once the junction temperature cools down by a thermal shutdown hysteresis ( $\Delta T_{SD}$ ), the IC will resume normal operation with a complete soft-start.

## Pin-Short Protection

The RTQ2117A provides pin-short protection for neighbor pins. The internal protection fuse will be burned out to prevent IC smoke, fire and spark when BOOT pin is shorted to VIN pin

## VBUS Reset

To allow a charging port to renegotiate current with a portable device, the RTQ2117A uses the automatic VBUS reset function. When battery charging mode (BCM) is changed, the discharge circuit at the RST pin becomes active. This will pull SS pin to low by RST. Then the RTQ2117A turns off buck converter to disconnect power source to VBUS, then discharges VBUS by internal discharge circuit. And then turns on buck converter to reassert the VBUS voltage. If timeout event occurs, the system will do VBUS reset again until no timeout event occurred. The VBUS reset sequence for battery charging mode change as shown in Figure 5 and the reset time table as shown in Table 1.

The following conditions will trigger VBUS reset event, when re-power on.

- ▶ D+/D- OVP event
- ▶ Release OVP/UVP/OTP event
- ▶ FB pin drops below PGOOD level (typ. = 85%)

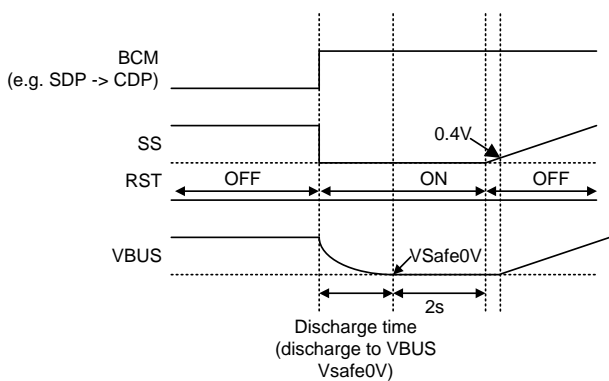

Figure 5. VBUS Reset Time Sequence

Table 1. VBUS Reset Time

BCM	Reset Time
DCP to CDP	400ms
CDP to DCP	2s
SDP to CDP	2s
CDP to SDP	2s
SDP to DCP	2s
DCP to SDP	400ms

## Data Switch

The RTQ2117A implements a high-bandwidth data switch can support USB 2.0 Hi-Speed (480Mbps) communication modes. When RTQ2117A is set to CDP or SDP mode, the data switch will be kept on for communication between Device and HOST unit. When VCC achieves POR level, the data switch is turned on after an internal delay time, 800µs (typically). When EN is disable, the VCC voltage is discharged to POR level and data switch is turned off at this time. The discharge time depends on external capacitor of VCC pin. The sequence is shown as Figure 6 and Figure 7.

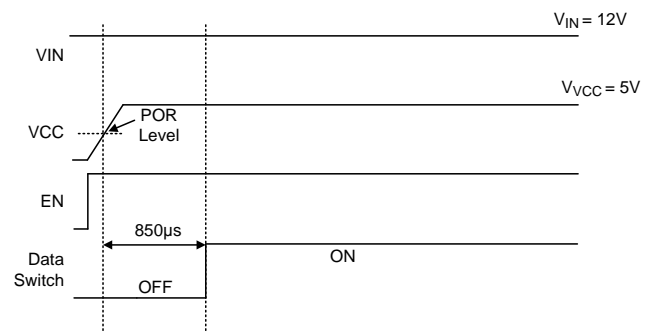

Figure 6. Data Switch On Sequence

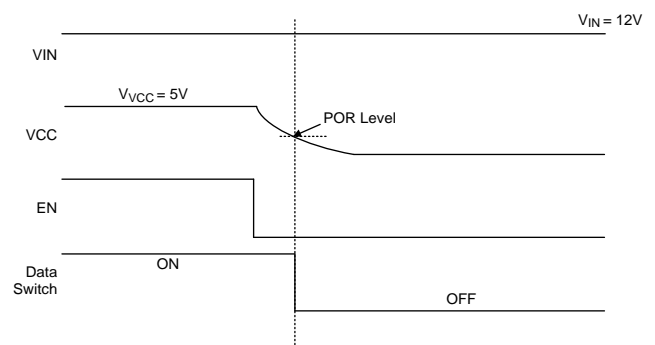

Figure 7. Data Switch Off Sequence

**DS+ DS- Over-Voltage Protection**

The RTQ2117A includes a data over-voltage protection function against the condition that DS+ or DS- suffers high voltage to let charging detection abnormal or damage the HOST device through data switch. When the voltage at DS+ or DS- is over protection trip threshold, 3.85V (typically), the PG will be pull low after 100μs and data switch will also be turned off after a fast response time, 5μs (typically). It is keep until the voltage is lower than threshold. Then, the PG is released after 100us and data switch recovery after a fast response time, 5μs (typically). When RTQ2117A detects the rising edge of VPGOOD, the VOUT/VBUS will be reset for a 400ms. This behavior will let charged devices re-attach and start the charging detection operation again. The sequence is shown as Figure 8.

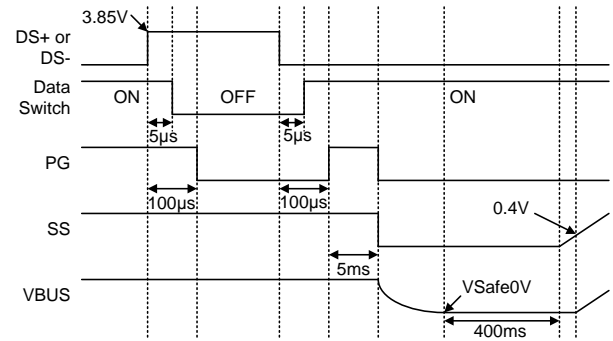

Figure 8. Data Over-Voltage Protection Sequence

## Absolute Maximum Ratings (Note 1)

• Supply Input Voltage, $V_{IN}$ -----	-0.3V to 42V
• Switch Voltage, $SW$ -----	-0.3V to 42V
<50ns -----	-5V to 46.3V
• BOOT Voltage, $V_{BOOT}$ -----	-0.3V to 48V
• BOOT to SW Voltage, $V_{BOOT-SW}$ -----	-0.3V to 6V
• EN, CSP, CSN, SS Voltage -----	-0.3V to 42V
• DS+, DS- Voltage -----	-0.3V to 20V
• VS Voltage -----	-0.3V to 24V
• Other Pins-----	-0.3V to 6V
• Power Dissipation, $P_D$ @ $T_A = 25^\circ C$	
WETD-VQFN-32L 5x5 -----	3.63W
• Package Thermal Resistance (Note 2)	
WETD-VQFN-32L 5x5, $\theta_{JA}$ -----	27.5°C/W
WETD-VQFN-32L 5x5, $\theta_{JC}$ -----	7°C/W
• Lead Temperature (Soldering, 10 sec.)-----	260°C
• Junction Temperature-----	150°C
• Storage Temperature Range-----	-65°C to 150°C
• ESD Susceptibility (Note 3)	
HBM (Human Body Model)	
DS+, DS-, VS Pins to AGND2 -----	8kV
Other Pins-----	2kV

## Recommended Operating Conditions (Note 4)

• Supply Input Voltage -----	3V to 36V
• Output Voltage -----	0.8V to 6V
• Ambient Temperature Range-----	-40°C to 125°C
• Junction Temperature Range -----	-40°C to 150°C

## Electrical Characteristics

( $V_{IN} = 12V$ ,  $T_J = -40^\circ C$  to  $125^\circ C$ , unless otherwise specified)

Parameter	Symbol	Test Conditions	Min	Typ	Max	Unit
<b>Supply Voltage</b>						
Input Operating Voltage	$V_{IN}$	Soft-start is finished	3	--	36	V
$V_{IN}$ Under-Voltage Lockout Threshold	$V_{UVLOH}$	$V_{IN}$ rising	3.6	3.8	4	V
	$V_{UVLOL}$	$V_{IN}$ falling	2.7	2.85	3	
Shutdown Current	$I_{SHDN}$	$V_{EN} = 0V$	--	--	5	$\mu A$
Quiescent Current	$I_Q$	$V_{EN} = 2V$ , $V_{FB} = 0.82V$ , not switching, $BCM = 0$ , $V_{CC} = 5V$ , Type A unattached	--	150	200	$\mu A$

Parameter	Symbol	Test Conditions	Min	Typ	Max	Unit
<b>Constant Voltage Regulation</b>						
Reference Voltage for Constant Voltage regulation	V <sub>REF_CV</sub>	3V < V <sub>IN</sub> < 36V, PWM, T <sub>A</sub> = T <sub>J</sub> = 25°C	0.792	0.8	0.808	V
		3V < V <sub>IN</sub> < 36V, PWM, T <sub>A</sub> = T <sub>J</sub> = -40°C to 125°C	0.788	0.8	0.812	
<b>Enable Voltage</b>						
Enable Threshold Voltage	V <sub>IH</sub>	V <sub>EN</sub> rising	1.15	1.25	1.35	V
	V <sub>IL</sub>	V <sub>EN</sub> falling	0.9	1.05	1.15	
<b>Current Limit</b>						
High-Side Switch Current Limit 1	I <sub>LIM_H1</sub>	RLIM = 91kΩ	1.87	2.2	2.53	A
High-Side Switch Current Limit 2	I <sub>LIM_H2</sub>	RLIM = 47kΩ	3.52	4.00	4.48	A
High-Side Switch Current Limit 3	I <sub>LIM_H3</sub>	RLIM = 33kΩ	4.84	5.5	6.16	A
Low-Side Switch Sinking Current Limit	I <sub>SK_L</sub>	From drain to source	--	2	--	A
<b>Switching</b>						
Switching Frequency 1	f <sub>SW1</sub>	R <sub>RT</sub> = 174kΩ	264	300	336	kHz
Switching Frequency 2	f <sub>SW2</sub>	R <sub>RT</sub> = 51kΩ	0.88	0.98	1.08	MHz
Switching Frequency 3	f <sub>SW3</sub>	R <sub>RT</sub> = 21kΩ	1.98	2.2	2.42	MHz
SYNC Frequency Range			0.3	--	2.2	MHz
SYNC Switching High Threshold	V <sub>IH_SYNC</sub>		--	--	2	V
SYNC Switching Low Threshold	V <sub>IL_SYNC</sub>		0.4	--	--	V
SYNC Switching Clock Duty Cycle	D <sub>SYNC</sub>		20	--	80	%
Minimum On-Time	t <sub>ON_MIN</sub>		--	60	80	ns
Minimum Off-Time	t <sub>OFF_MIN</sub>		--	65	80	ns
<b>Internal MOSFET</b>						
High-Side Switch On-Resistance	R <sub>DS(ON)_H</sub>		--	70	130	mΩ
Low-Side Switch On-Resistance	R <sub>DS(ON)_L</sub>		--	70	130	mΩ
High-Side Switch Leakage Current	I <sub>LEAK_H</sub>	V <sub>EN</sub> = 0V, V <sub>SW</sub> = 0V	--	--	1	μA
<b>Soft-Start</b>						
Soft-Start Internal Charging Current	I <sub>SS</sub>		4.5	6	7.2	μA

Parameter	Symbol	Test Conditions	Min	Typ	Max	Unit
<b>Power Good</b>						
Power Good High Threshold 1	$V_{TH\_PGLH1}$	$V_{FB}$ rising, % of $V_{REF\_CV}$ , PGOOD from low to high	85	90	95	%
Power Good Low Threshold 1	$V_{TH\_PGHL1}$	$V_{FB}$ rising, % of $V_{REF\_CV}$ , PGOOD from high to low	115	120	125	
Power Good Low Threshold 2	$V_{TH\_PGHL2}$	$V_{FB}$ falling, % of $V_{REF\_CV}$ , PGOOD from high to low	80	85	90	%
Power Good High Threshold 2	$V_{TH\_PGLH2}$	$V_{FB}$ falling, % of $V_{REF\_CV}$ , PGOOD from low to high	112	117	122	
Power Good Leakage Current	$I_{LK\_PGOOD}$	PGOOD signal good, $V_{FB} = V_{REF}$ , $V_{PGOOD} = 5.5V$	--	--	0.5	$\mu A$
Power Good Sink Current Capability	$I_{SK\_PGOOD}$	PGOOD signal fault, $I_{PGOOD}$ sinks 2mA	--	--	0.3	V
<b>Error Amplifier</b>						
Error Amplifier Trans-conductance	gm	$-10\mu A < I_{COMP} < 10\mu A$	665	950	1280	$\mu A/V$
COMP to Current Sense Trans-conductance	gm_CS		4.5	5.6	6.7	A/V
<b>Load Line Compensation</b>						
Load Line Compensation Current	$I_{LC}$	$V_{CSP} - V_{CSN} = 100mV$ , $5V < V_{CSP}$ and $V_{CSN} < 6V$	--	2	--	$\mu A$
		$V_{CSP} - V_{CSN} = 50mV$ , $5V < V_{CSP}$ and $V_{CSN} < 6V$	--	0.95	--	
<b>Constant Current Regulation</b>						
Reference Voltage for Constant Current Regulation	$V_{REF\_CC}$	$V_{CSP} - V_{CSN}$ , $3.3V < V_{CSP}$ and $V_{CSN} < 6V$	--	100	--	mV
<b>Spread Spectrum</b>						
Spread-Spectrum Range	SSP	Spread-spectrum option only	--	+6	--	%
<b>Over-Temperature Protection</b>						
Thermal Shutdown	$T_{SD}$		--	175	--	$^{\circ}C$
Thermal Shutdown Hysteresis	$\Delta T_{SD}$		--	15	--	$^{\circ}C$
Switching Pin Discharge Resistance		Force 1V	--	100	160	$\Omega$
<b>Output Under-Voltage Protection</b>						
UVP Trip Threshold	$V_{UVP}$	UVP detect	0.35	0.4	0.45	V
<b>BCM</b>						
Input Pin L $\rightarrow$ H Threshold Voltage	$V_{TH}$		1.05	1.15	1.25	V
Input Pin H $\rightarrow$ L Threshold Voltage	$V_{TL}$		0.3	0.4	0.5	V
Floating Voltage			0.7	0.8	0.9	V

Parameter	Symbol	Test Conditions	Min	Typ	Max	Unit
<b>High-Bandwidth Analog Switch</b>						
DH+/DH- ↔ DS+/DS- Switch On Resistance	R <sub>DS(ON)_SW</sub>	DH+/DH- = 0V, 0.4V I <sub>ON</sub> = 8mA (Note 6)	--	5	--	Ω
Switch Resistance Mismatch between DH+/DH- Channel	R <sub>DS(ON)_SW_MIS</sub>	DH+/DH- = 0V, 0.4V I <sub>ON</sub> = 8mA (Note 6)	--	0.03	--	Ω
DH+/DH-/DS+/DS- Switch Off-State Capacitance	C <sub>OFF</sub>	f <sub>SW</sub> = 240MHz (Note 5)	--	2	--	pF
DH+/DH-/DS+/DS- Switch On-State Capacitance	C <sub>ON</sub>	f <sub>SW</sub> = 240MHz (Note 5)	--	4.2	--	pF
Off-State Isolation	O <sub>IRR</sub>	f <sub>SW</sub> = 240MHz, DH+/DH- = 400mV <sub>PP</sub> , R <sub>L</sub> = 50Ω, C <sub>L</sub> = 0pF on DS+/DS- (Note 5)	--	-30	--	dB
Differential -3dB Bandwidth	f <sub>BW</sub>	DH+/DH- = 400mV <sub>PP</sub> , R <sub>L</sub> = 50Ω, C <sub>L</sub> = 0pF on DS+/DS- (Note 5)	--	1.2	--	GHz
Propagation Delay (Note 6)	t <sub>PD</sub>		--	0.25	--	ns
Skew between Opposite Transitions of the Same Port (t <sub>PHL</sub> - t <sub>PLH</sub> )	t <sub>SK</sub>	Rising/falling time of DH+/DH- = 500ps (10-90%) at 240MHz, C <sub>L</sub> = 5pF, R <sub>L</sub> = 50Ω (Note 5)	--	0.1	--	ns
<b>DCP Shorted Mode</b>						
DS+/DS- Shorting Resistance	R <sub>DCP_SHORT</sub>	DS+ = 0.8V, I <sub>DS-</sub> = 1mA	--	--	200	Ω
Resistance Between DS+/DS- and Ground	R <sub>DCHG_SHORT</sub>	DS+/DS- = 0.8V	300	--	--	kΩ
<b>1.2V Shorted Mode</b>						
DS+ Output Voltage	V <sub>DP_1.2V</sub>		1.12	1.2	1.28	V
DS+ Output Impedance	R <sub>DP_1.2V</sub>		80	102	130	kΩ
<b>Divider 3 Mode</b>						
DS+ Output Voltage	V <sub>DP_2.7V</sub>		2.57	2.7	2.84	V
DS- Output Voltage	V <sub>DM_2.7V</sub>		2.57	2.7	2.84	V
DS+ Output Impedance	R <sub>DP_2.7V</sub>		24	30	36	kΩ
DS- Output Impedance	R <sub>DM_2.7V</sub>		24	30	36	kΩ
<b>Charging Downstream Port</b>						
DS- CDP Output Voltage	V <sub>DM_SRC</sub>		0.5	--	0.7	V
DS+ Rising Lower Window Threshold for V <sub>DM_SRC</sub> Activation	V <sub>DAT_REF</sub>		0.25	--	0.4	V
DS+ Rising Upper Window Threshold for V <sub>DM_SRC</sub> De-Activation	V <sub>LGC_SRC</sub>		0.8	--	2	V
DS+ Sink Current	I <sub>DP_SINK</sub>		50	--	150	μA
<b>D+, D- Analog USB Switches</b>						
Analog Signal Range			0	--	3.6	V
Protection Trip Threshold	V <sub>OV_D</sub>		3.7	3.85	4.15	V

Parameter	Symbol	Test Conditions	Min	Typ	Max	Unit
Protection Response Time	$t_{FP\_D}$	$V_{IN} = 4V$ , $V_{HVD\pm} = 3.3V$ to $4.3V$ step, $R_L = 15k\Omega$ on $D_{\pm}$ , delay to $V_{D\pm} < 3V$ (Note 5)	--	5	--	$\mu s$

**Note 1.** Stresses beyond those listed under “Absolute Maximum Ratings” may cause permanent damage to the RTQ2117A. These are stress ratings only, and functional operation of the RTQ2117A at these or any other conditions beyond those indicated in the operational sections of the specifications is not implied. Exposure to absolute maximum rating conditions may affect RTQ2117A reliability.

**Note 2.**  $\theta_{JA}$  is measured under natural convection (still air) at  $T_A = 25^\circ C$  with the component mounted on a high effective-thermal-conductivity four-layer test board on a JEDEC 51-7 thermal measurement standard. The first layer is filled with copper.  $\theta_{JC}$  is measured at the exposed pad of the package.

**Note 3.** The RTQ2117A are ESD sensitive. Handling precaution is recommended.

**Note 4.** The RTQ2117A is not guaranteed to function outside its operating conditions.

**Note 5.** Guarantee by design.



**Typical Application Circuit**

Step-Down Circuit with  
 Cable Drop Compensation : 240mV@2.4A  
 Average Current Limit : 2.9A

2100kHz, 5V, 3A Step-Down Converter

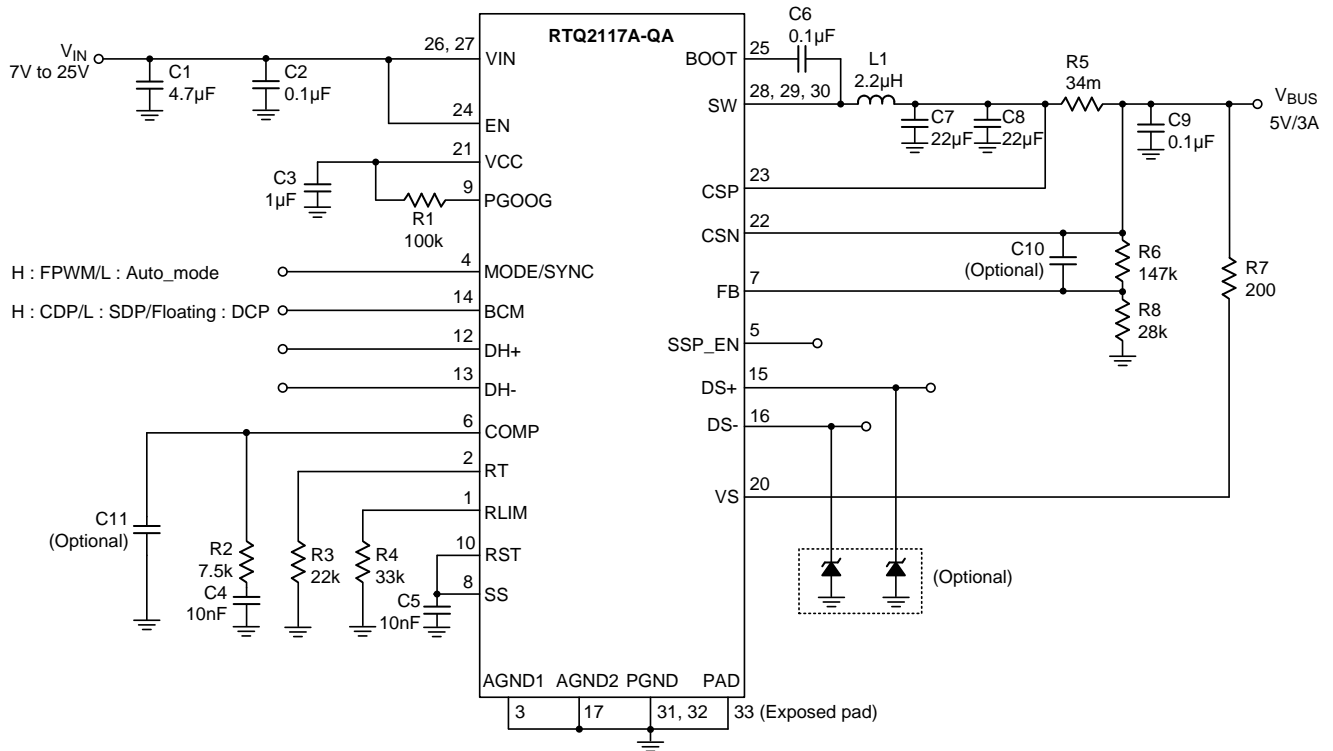

L1 = Cyntec-VCHA075D-2R2MS6  
 C7/C8 = GRM31CR71A226KE15L  
 C1 = GRM31CR71H475KA12L

## Typical Operating Characteristics

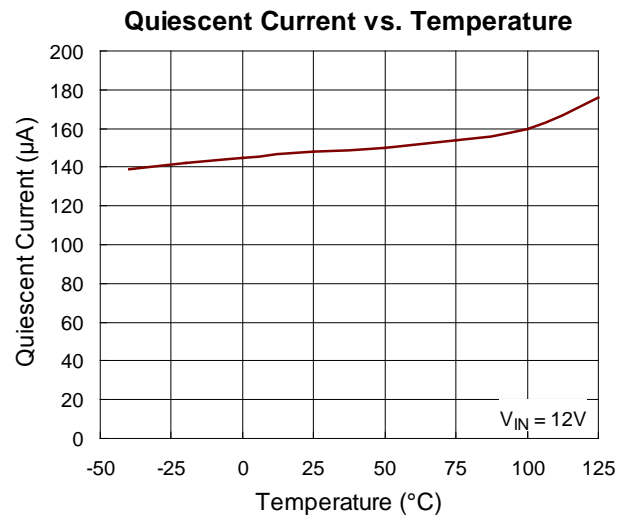
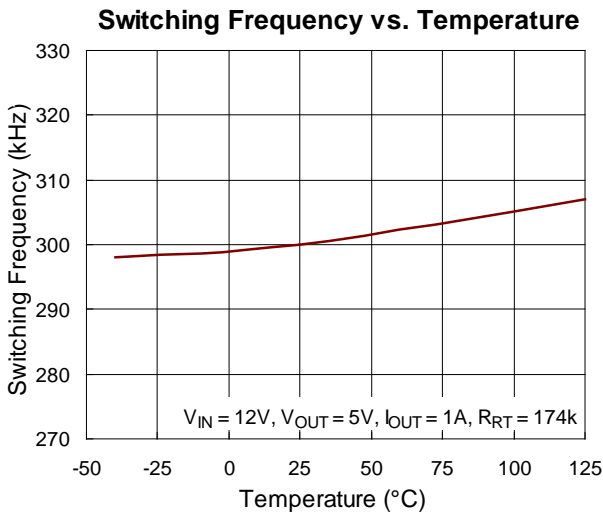
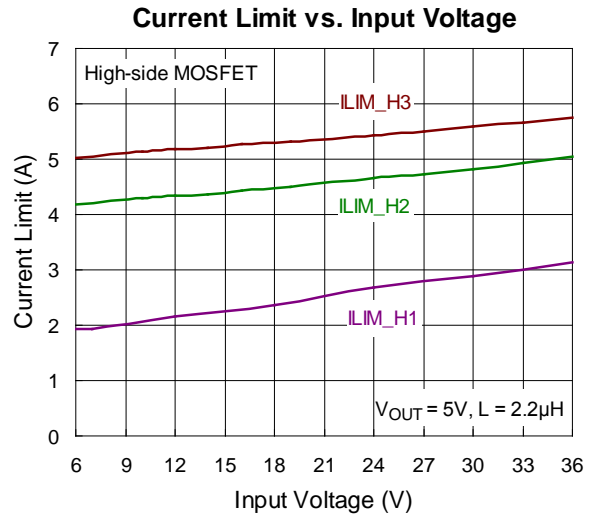
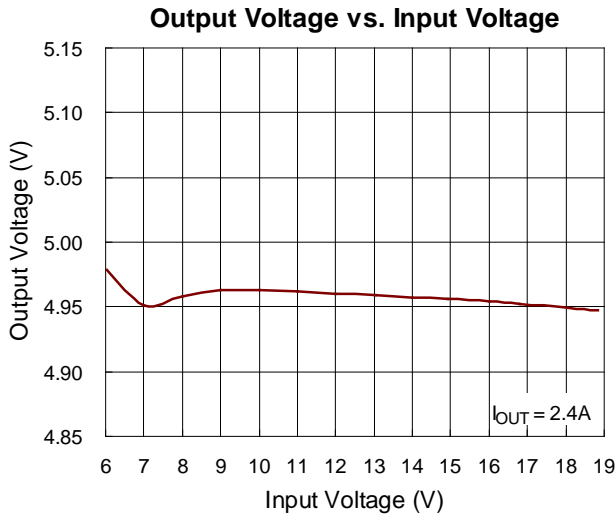
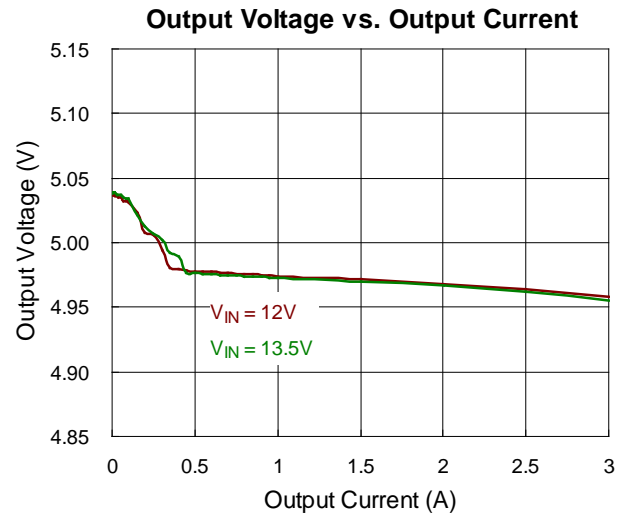
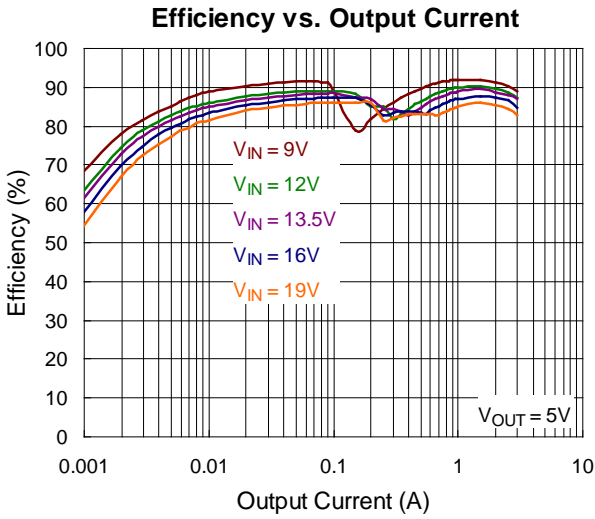

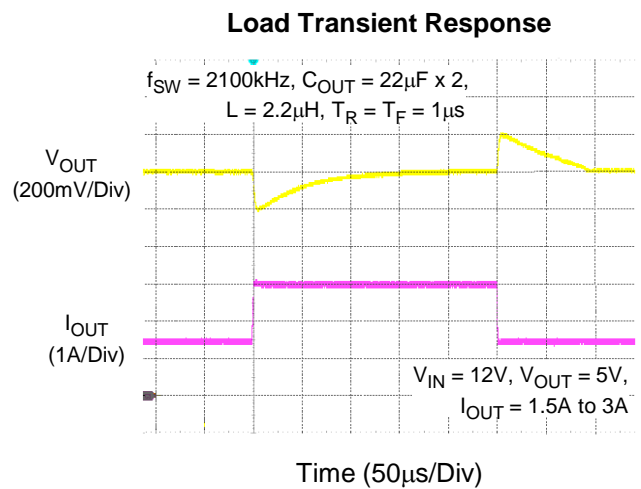
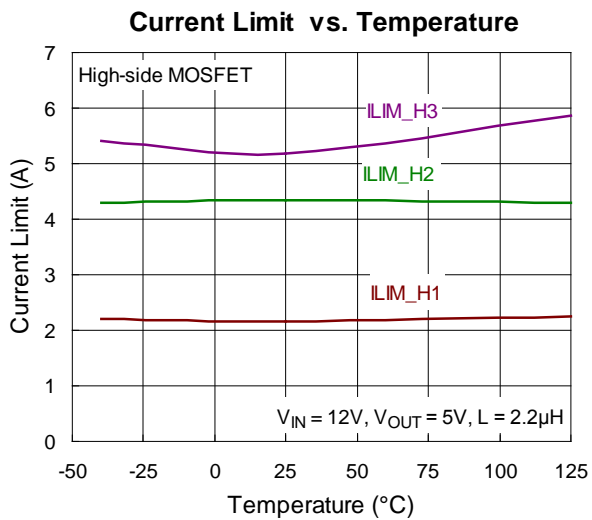
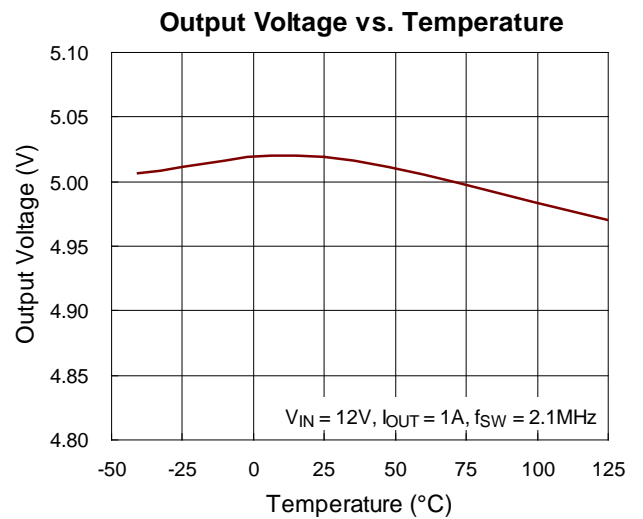
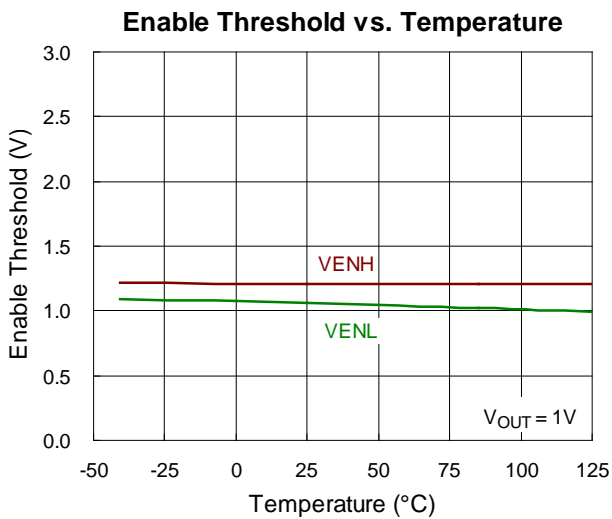
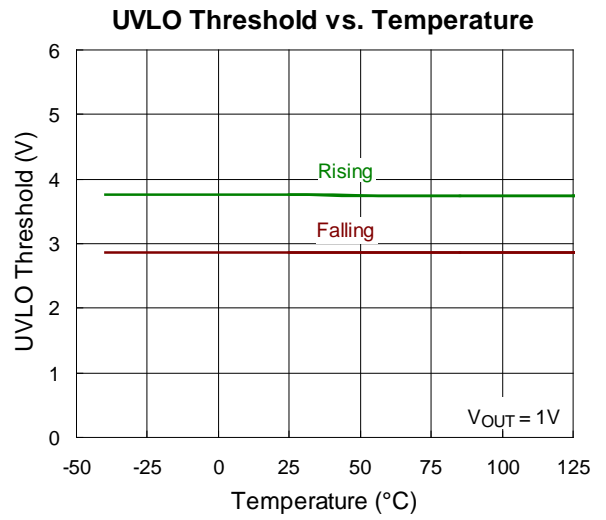
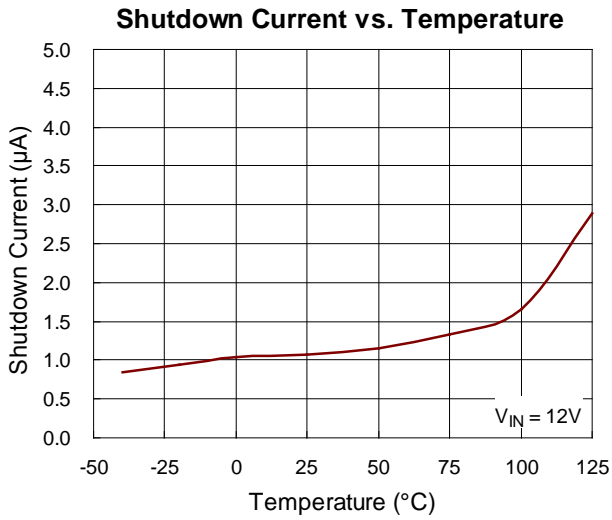

### Output Ripple Voltage

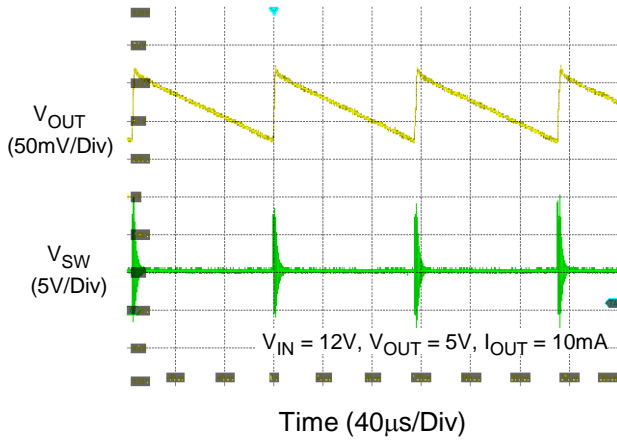

### Output Ripple Voltage

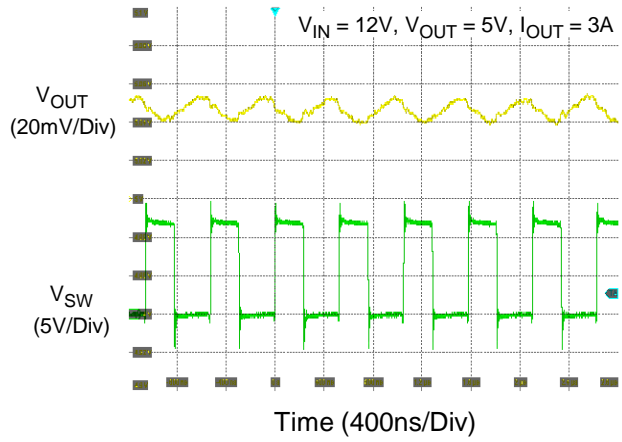

### Eye Diagram

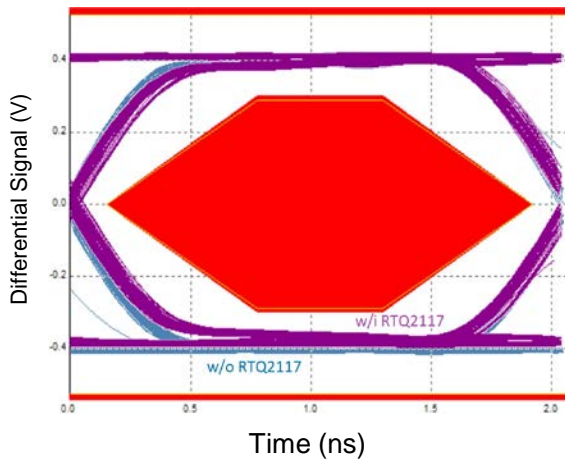

## Application Information

A general RTQ2117A application circuit is shown in typical application circuit section. External component selection is largely driven by the load requirement and begins with the selection of operating mode by setting the MODE/SYNC pin voltage and the operating frequency by using external resistor RT. Next, the inductor L is chosen and then the input capacitor C<sub>IN</sub>, the output capacitor C<sub>OUT</sub>. Next, feedback resistors and compensation circuit are selected to set the desired output voltage, crossover frequency, the internal regulator capacitor C<sub>VCC</sub>, and the bootstrap capacitor C<sub>BOOT</sub> can be selected. Finally, the remaining optional external components can be selected for functions such as the EN, external soft-start, PGOOD, inductor peak current limit, synchronization, spread spectrum, average current limit, and adjustable output voltage with cable drop compensation.

### FPWM/PSM Selection

The RTQ2117A provides an MODE/SYNC pin for Forced-PWM Mode (FPWM) and Power Saving Mode (PSM) operation selection at light load. To optimize efficiency at light loads, the RTQ2117A can be set in PSM. The V<sub>MODE/SYNC</sub> is held below a logic-low threshold voltage (V<sub>IL\_SYNC</sub>) of the MODE/SYNC input, that is, with the MODE/SYNC pin floating or pull low, the RTQ2117A operates in PSM at light load to improve light load efficiency. If it is necessary to keep switching harmonics out of the signal band, the RTQ2117A can operate in FPWM. The RTQ2117A is locked in PWM mode when V<sub>MODE/SYNC</sub> rises above a logic-high threshold voltage (V<sub>IH\_SYNC</sub>) of the MODE/SYNC input. The FPWM trades off reduced light load efficiency for low output voltage ripple, tight output voltage regulation, fast transient response, and constant switching frequency.

### Switching Frequency Setting

The RTQ2117A offers adjustable switching frequency setting and the switching frequency can be set by using external resistor RT. Switching frequency range is from 300kHz to 2.2MHz. Selection of the operating frequency is a trade-off between efficiency and component size. High frequency operation allows the

use of smaller inductor and capacitor values. Operation at lower frequencies improves efficiency by reducing internal gate charge and transition losses, but requires larger inductance values and/or capacitance to maintain low output ripple voltage. An additional constraint on operating frequency are the minimum on-time and minimum off-time. The minimum on-time, t<sub>ON\_MIN</sub>, is the smallest duration of time in which the high-side switch can be in its “on” state. This time is 60ns (typically). In continuous mode operation, the minimum on-time limit imposes a maximum operating frequency, f<sub>SW\_MAX</sub>, of :

$$f_{SW\_MAX} = \frac{V_{OUT}}{t_{ON\_MIN} \times V_{IN\_MAX}}$$

where V<sub>IN\_MAX</sub> is the maximum operating input voltage. The minimum off-time, t<sub>OFF\_MIN</sub>, is the smallest amount of time that the RTQ2117A is capable of turning on the low-side MOSFET switch, tripping the current comparator and turning the MOSFET switch back off. The minimum off time is 65ns (typically). If the switching frequency should be constant, the required off time needs to be larger than minimum off time. Below shows minimum off time calculation with loss terms consideration,

$$t_{OFF\_MIN} \leq \frac{1 - \left[ \frac{V_{OUT} + I_{OUT\_MAX} \times (R_{DS(ON)_L} + R_L)}{V_{IN\_MIN} - I_{OUT\_MAX} \times (R_{DS(ON)_H} - R_{DS(ON)_L})} \right]}{f_{sw}}$$

where R<sub>DS(ON)\_H</sub> is the on resistance of the high-side MOSFET switch; R<sub>DS(ON)\_L</sub> is the on resistance of the low-side MOSFET switch; R<sub>L</sub> is the DC resistance of inductor.

Through external resistor R<sub>RT</sub> connect between RT pin and GND to set the switching frequency f<sub>sw</sub>. The failure modes and effects analysis (FMEA) consideration is applied to RT pin setting to avoid abnormal switching frequency operation at failure condition. It includes failure scenarios of short-circuit to GND and the pin is left open. The switching frequency will be 2.35MHz (typically) when the RT pin short to GND and 250kHz (typically) when the pin is left open. The equation below shows the relation between setting frequency and R<sub>RT</sub> value.

$$R_{RT(k\Omega)} = 74296 \times f_{sw}^{-1.06}$$

Where  $f_{sw}$  (kHz) is the desired setting frequency. It is recommended to use 1% tolerance or better and temperature coefficient of 100 ppm or less resistors. The Figure 9 shows the relationship between switching frequency and  $R_{RT}$  resistor.

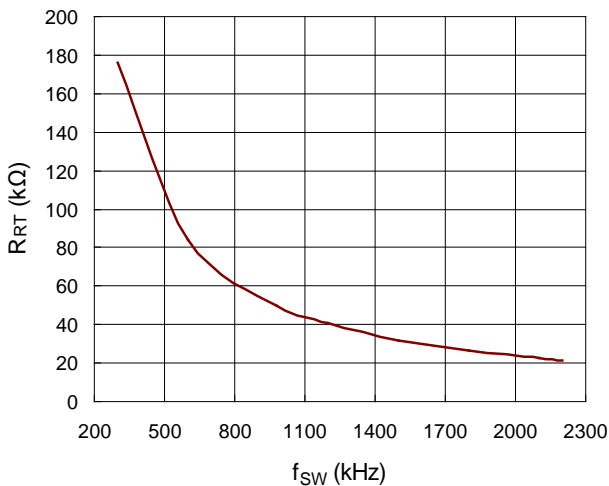

Figure 9. Switching Frequency vs.  $R_{RT}$  Resistor

### Inductor Selection

The inductor selection trade-offs among size, cost, efficiency, and transient response requirements. Generally, three key inductor parameters are specified for operation with the RTQ2117A: inductance value (L), inductor saturation current ( $I_{SAT}$ ), and DC resistance (DCR).

A good compromise between size and loss is a 30% peak-to-peak ripple current to the IC rated current. The switching frequency, input voltage, output voltage, and selected inductor ripple current determines the inductor value as follows :

$$L = \frac{V_{OUT} \times (V_{IN} - V_{OUT})}{V_{IN} \times f_{SW} \times \Delta I_L}$$

Larger inductance values result in lower output ripple voltage and higher efficiency, but a slightly degraded transient response. This results in additional phase lag in the loop and reduce the crossover frequency. As the ratio of the slope-compensation ramp to the sensed-current ramp increases, the current-mode system tilts towards voltage-mode control. Lower inductance values allow for smaller case size, but the

increased ripple lowers the effective current limit threshold, increases the AC losses in the inductor and may trigger low-side switch sinking current limit at FPWM. It also causes insufficient slope compensation and ultimately loop instability as duty cycle approaches or exceeds 50%. When duty cycle exceeds 50%, below condition needs to be satisfied :

$$2.1 \times f_{SW} > \frac{V_{OUT}}{L}$$

A good compromise among size, efficiency, and transient response can be achieved by setting an inductor current ripple ( $\Delta I_L$ ) with about 10% to 50% of the maximum rated output current (3A).

To enhance the efficiency, choose a low-loss inductor having the lowest possible DC resistance that fits in the allotted dimensions. The inductor value determines not only the ripple current but also the load-current value at which DCM/CCM switchover occurs. The inductor selected should have a saturation current rating greater than the peak current limit of the RTQ2117A. The core must be large enough not to saturate at the peak inductor current ( $I_{L\_PEAK}$ ) :

$$\Delta I_L = \frac{V_{OUT} \times (V_{IN} - V_{OUT})}{V_{IN} \times f_{SW} \times L}$$

$$I_{L\_PEAK} = I_{OUT\_MAX} + \frac{1}{2} \Delta I_L$$

The current flowing through the inductor is the inductor ripple current plus the output current. During power up, faults or transient load conditions, the inductor current can increase above the calculated peak inductor current level calculated above. In transient conditions, the inductor current can increase up to the switch current limit of the RTQ2117A. For this reason, the most conservative approach is to specify an inductor with a saturation current rating equal to or greater than the switch current limit rather than the peak inductor current. It is recommended to use shielded inductors for good EMI performance.

**Input Capacitor Selection**

Input capacitance,  $C_{IN}$ , is needed to filter the pulsating current at the drain of the high-side power MOSFET.  $C_{IN}$  should be sized to do this without causing a large variation in input voltage. The peak-to-peak voltage ripple on input capacitor can be estimated as equation below :

$$\Delta V_{CIN} = D \times I_{OUT} \times \frac{1-D}{C_{IN} \times f_{SW}} + ESR \times I_{OUT}$$

Where

$$D = \frac{V_{OUT}}{V_{IN} \times \eta}$$

For ceramic capacitors, the equivalent series resistance (ESR) is very low, the ripple which is caused by ESR can be ignored, and the minimum value of effective input capacitance can be estimated as equation below :

$$C_{IN\_MIN} = I_{OUT\_MAX} \times \frac{D(1-D)}{\Delta V_{CIN\_MAX} \times f_{SW}}$$

Where  $\Delta V_{CIN\_MAX} \leq 200mV$

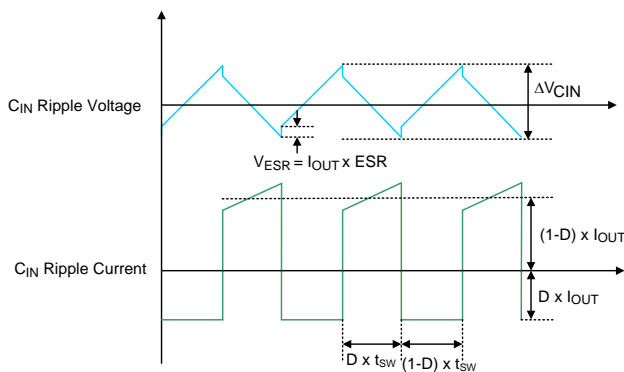

Figure 10.  $C_{IN}$  Ripple Voltage and Ripple Current

In addition, the input capacitor needs to have a very low ESR and must be rated to handle the worst-case RMS input current. The RMS ripple current ( $I_{RMS}$ ) of the regulator can be determined by the input voltage ( $V_{IN}$ ), output voltage ( $V_{OUT}$ ), and rated output current ( $I_{OUT}$ ) as the following equation :

$$I_{RMS} \cong I_{OUT\_MAX} \times \frac{V_{OUT}}{V_{IN}} \times \sqrt{\frac{V_{IN}}{V_{OUT}} - 1}$$

From the above, the maximum RMS input ripple current occurs at maximum output load, which will be

used as the requirements to consider the current capabilities of the input capacitors. The maximum ripple voltage usually occurs at 50% duty cycle, that is,  $V_{IN} = 2 \times V_{OUT}$ . It is commonly to use the worse  $I_{RMS} \cong 0.5 \times I_{OUT\_MAX}$  at  $V_{IN} = 2 \times V_{OUT}$  for design. Note that ripple current ratings from capacitor manufacturers are often based on only 2000 hours of life which makes it advisable to further de-rate the capacitor, or choose a capacitor rated at a higher temperature than required.

Several capacitors may also be paralleled to meet size, height and thermal requirements in the design. For low input voltage applications, sufficient bulk input capacitance is needed to minimize transient effects during output load changes.

Ceramic capacitors are ideal for witching regulator applications due to its small, robust and very low ESR. However, care must be taken when these capacitors are used at the input. A ceramic input capacitor combined with trace or cable inductance forms a high quality (under damped) tank circuit. If the RTQ2117A circuit is plugged into a live supply, the input voltage can ring to twice its nominal value, possibly exceeding the RTQ2117A's rating. This situation is easily avoided by placing the low ESR ceramic input capacitor in parallel with a bulk capacitor with higher ESR to damp the voltage ringing.

The input capacitor should be placed as close as possible to the  $V_{IN}$  pin, with a low inductance connection to the PGND of the IC. It is recommended to connect a  $4.7\mu F$ , X7R capacitors between  $V_{IN}$  pin to PGND pin for 2.1MHz switching frequency. The larger input capacitance is required when a lower switching frequency is used. For filtering high frequency noise, additional small capacitor  $0.1\mu F$  should be placed close to the part and the capacitor should be 0402 or 0603 in size. X7R capacitors are recommended for best performance across temperature and input voltage variations.

**Output Capacitor Selection**

The selection of  $C_{OUT}$  is determined by considering to satisfy the voltage ripple and the transient loads. The peak-to-peak output ripple,  $\Delta V_{OUT}$ , is determined by :

$$\Delta V_{OUT} = \Delta I_L \left( ESR + \frac{1}{8 \times C_{OUT} \times f_{SW}} \right)$$

Where the  $\Delta I_L$  is the peak-to-peak inductor ripple current. The output ripple is highest at maximum input voltage since  $\Delta I_L$  increases with input voltage. Multiple capacitors placed in parallel may be needed to meet the ESR and RMS current handling requirements.

Regarding to the transient loads, the  $V_{SAG}$  and  $V_{SOAR}$  requirement should be taken into consideration for choosing the effective output capacitance value. The amount of output sag/soar is a function of the crossover frequency factor at PWM, which can be calculated from below.

$$V_{SAG} = V_{SOAR} = \frac{\Delta I_{OUT}}{2 \times \pi \times C_{OUT} \times f_C}$$

Ceramic capacitors have very low equivalent series resistance (ESR) and provide the best ripple performance. The recommended dielectric type of the capacitor is X7R best performance across temperature and input voltage variations. The variation of the capacitance value with temperature, DC bias voltage and switching frequency needs to be taken into consideration. For example, the capacitance value of a capacitor decreases as the DC bias across the capacitor increases. Be careful to consider the voltage coefficient of ceramic capacitors when choosing the value and case size. Most ceramic capacitors lose 50% or more of their rated value when used near their rated voltage.

Transient performance can be improved with a higher value output capacitor. Increasing the output capacitance will also decrease the output voltage ripple.

### Output Voltage Programming

The output voltage can be programmed by a resistive divider from the output to ground with the midpoint connected to the FB pin. The resistive divider allows the FB pin to sense a fraction of the output voltage as shown in Figure 11. The output voltage is set according to the following equation :

$$V_{OUT} = V_{REF\_CV} \times \left( 1 + \frac{R1}{R2} \right)$$

where the reference voltage of constant voltage control  $V_{REF\_CV}$ , is 0.8V (typically).

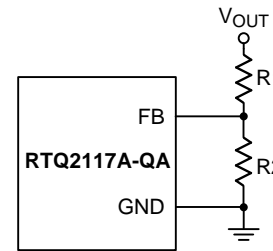

Figure 11. Output Voltage Setting

The placement of the resistive divider should be within 5mm of the FB pin. The resistance of R2 is not larger than 170k $\Omega$  for noise immunity consideration. The resistance of R1 can then be obtained as below :

$$R1 = \frac{R2 \times (V_{OUT} - V_{REF\_CV})}{V_{REF\_CV}}$$

For better output voltage accuracy, the divider resistors (R1 and R2) with  $\pm 1\%$  tolerance or better should be used. Note that the resistance of R1 relates to cable drop compensation setting. The resistance of R1 should be designed to match the needs of the voltage drop application, see the adjustable output voltage with cable drop compensation section.

### Compensation Network Design

The purpose of loop compensation is to ensure stable operation while maximizing the dynamic performance. An undercompensated system may result in unstable operations. Typical symptoms of an unstable power supply include : audible noise from the magnetic components or ceramic capacitors, jittering in the switching waveforms, oscillation of output voltage, overheating of power MOSFETs and so on.

In most cases, the peak current mode control architecture used in the RTQ2117A only requires two external components to achieve a stable design as shown in Figure 13. The compensation can be selected to accommodate any capacitor type or value. The external compensation also allows the user to set the crossover frequency and optimize the transient performance of the RTQ2117A. Around the crossover frequency the peak current mode control (PCMC) equivalent circuit of Buck converter can be simplified as shown in Figure 14. The method presented here is easy to calculate and ignores the effects of the slope compensation that is internal to the RTQ2117A. Since



the slope compensation is ignored, the actual cross over frequency will usually be lower than the crossover frequency used in the calculations. It is always necessary to make a measurement before releasing the design for final production. Though the models of power supplies are theoretically correct, they cannot take full account of circuit parasitic and component nonlinearity, such as the ESR variations of output capacitors, then on linearity of inductors and capacitors, etc. Also, circuit PCB noise and limited measurement accuracy may also cause measurement errors. A Bode plot is ideally measured with a network analyzer while Richtek application note [AN038](#) provides an alternative way to check the stability quickly and easily. Generally, follow the following steps to calculate the compensation components :

1. Set up the crossover frequency,  $f_c$ . For stability purposes, our target is to have a loop gain slope that is  $-20\text{dB/decade}$  from a very low frequency to beyond the crossover frequency. In general, one-twentieth to one-tenth of the switching frequency ( $5\%$  to  $10\%$  of  $f_{\text{SW}}$ ) is recommended to be the crossover frequency. Do "NOT" design the crossover frequency over  $80\text{kHz}$  when switching frequency is larger than  $800\text{kHz}$ . For dynamic purposes, the higher the bandwidth, the faster the load transient response. The downside to high bandwidth is that it increases the regulators susceptibility to board noise which ultimately leads to excessive falling edge jitter of the switch node voltage.

2.  $R_{\text{COMP}}$  can be determined by :

$$R_{\text{COMP}} = \frac{2\pi \times f_c \times V_{\text{OUT}} \times C_{\text{OUT}}}{g_m \times V_{\text{REF\_CV}} \times g_{m\_CS}} = \frac{2\pi \times f_c \times C_{\text{OUT}}}{g_m \times g_{m\_CS}} \times \frac{R_1 + R_2}{R_2}$$

where

$g_m$  is the error amplifier gain of trans-conductance ( $950\mu\text{A/V}$ )

$g_{m\_CS}$  is COMP to current sense ( $5.6\text{A/V}$ )

3. A compensation zero can be placed at or before the dominant pole of buck which is provided by output capacitor and maximum output loading ( $R_L$ ). Calculate  $C_{\text{COMP}}$  :

$$C_{\text{COMP}} = \frac{R_L \times C_{\text{OUT}}}{R_{\text{COMP}}}$$

4. The compensation pole is set to the frequency at the ESR zero or  $1/2$  of the operating frequency. Output capacitor and its ESR provide a zero and optional  $C_{\text{COMP2}}$  can be used to cancel this zero

$$C_{\text{COMP2}} = \frac{R_{\text{ESR}} \times C_{\text{OUT}}}{R_{\text{COMP}}}$$

If  $1/2$  of the operating frequency is lower than the ESR zero, the compensation pole is set at  $1/2$  of the operating frequency.

$$C_{\text{COMP2}} = \frac{1}{2 \times \pi \times \frac{f_{\text{SW}}}{2} \times R_{\text{COMP}}}$$

NOTE : Generally,  $C_{\text{COMP2}}$  is an optional component to be used to enhance noise immunity.

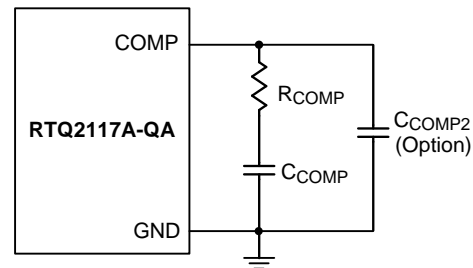

Figure 12. External Compensation Components

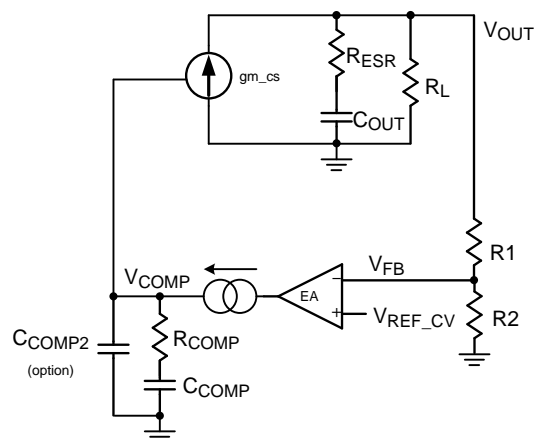

Figure 13. Simplified Equivalent Circuit of Buck with PCMC

## Internal Regulator

The RTQ2117A integrates a 5V linear regulator (VCC) that is supplied by VIN and provides power to the internal circuitry. The internal regulator operates in low dropout mode when  $V_{VIN}$  is below 5V. The VCC can be used as the PGOOD pull-up supply but it is “NOT” allowed to power other device or circuitry. The VCC pin must be bypassed to ground with a minimum of 0.7 $\mu$ F, X7R ceramic capacitor, placed as close as possible to the VCC pin. In many applications, a 1 $\mu$ F, 16V, 0603, X7R is a suitable choice. Be careful to account for the voltage coefficient of ceramic capacitors when choosing the value and case size. Many ceramic capacitors lose 50% or more of their rated value when used near their rated voltage.

## Bootstrap Driver Supply

The bootstrap capacitor ( $C_{BOOT}$ ) between BOOT pin and SW pin is used to create a voltage rail above the applied input voltage, VIN. Specifically, the bootstrap capacitor is charged through an internal diode to a voltage equal to approximately  $V_{VCC}$  each time the low-side switch is turned on. The charge on this capacitor is then used to supply the required current during the remainder of the switching cycle. For most applications a 0.1 $\mu$ F, 0603 ceramic capacitor with X7R is recommended and the capacitor should have a 6.3 V or higher voltage rating.

## External Bootstrap Diode (Option)

It is recommended to add an external bootstrap diode between an external 5V voltage supply and the BOOT pin to improve enhancement of the high-side switch and improve efficiency when the input voltage is below 5.5V, the recommended application circuit is shown in Figure 14. The bootstrap diode can be a low-cost one, such as 1N4148 or BAT54. The external 5V can be a fixed 5V voltage supply from the system, or a 5V output voltage generated by the RTQ2117A. Note that the  $V_{BOOT-SW}$  must be lower than 5.5V. Figure 15 shows efficiency comparison between with and without Bootstrap Diode.

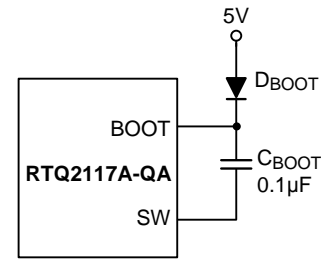

Figure 14. External Bootstrap Diode

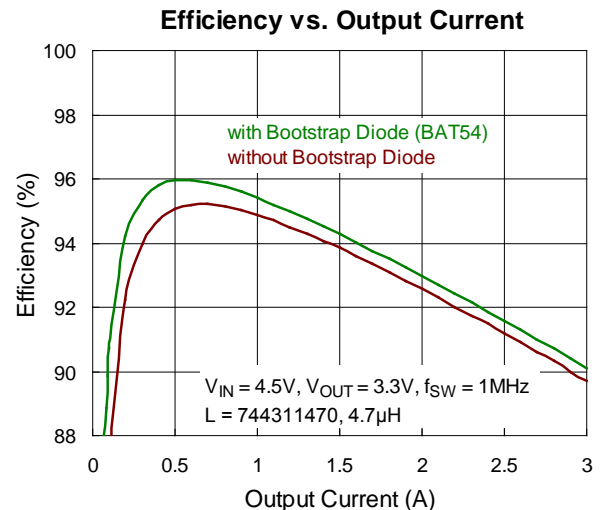

Figure 15. Efficiency Comparison between with and without Bootstrap Diode

## External Bootstrap Resistor (Option)

The gate driver of an internal power MOSFET, utilized as a high-side switch, is optimized for turning on the switch not only fast enough for reducing switching power loss, but also slow enough for minimizing EMI. The EMI issue is worse when the switch is turned on rapidly due to high di/dt noises induced. When the high-side switch is being turned off, the SW node will be discharged relatively slowly by the inductor current due to the presence of the dead time when both the high-side and low-side switches are turned off.

In some cases, it is desirable to reduce EMI further, even at the expense of some additional power dissipation. The turn-on rate of the high-side switch can be slowed by placing a small bootstrap resistor  $R_{BOOT}$  between the BOOT pin and the external bootstrap capacitor as shown in Figure 16. The recommended range for the  $R_{BOOT}$  is several ohms to 10 ohms and it could be 0402 or 0603 in size.

This will slow down the rates of the high-side switch turn-on and the rise of  $V_{SW}$ . In order to improve EMI performance and enhancement of the internal MOSFET switch, the recommended application circuit is shown in Figure 17, which includes an external bootstrap diode for charging the bootstrap capacitor and a bootstrap resistor  $R_{BOOT}$  being placed between the BOOT pin and the capacitor/diode connection.

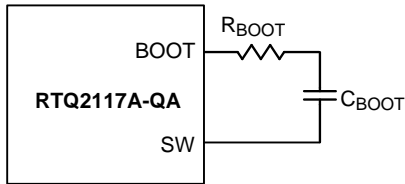

Figure 16. External Bootstrap Resistor at the BOOT Pin

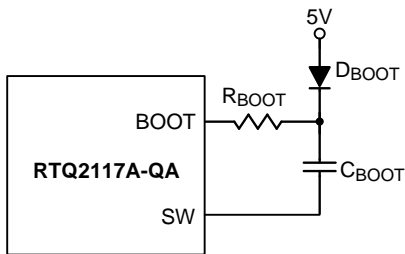

Figure 17. External Bootstrap Diode and Resistor at the BOOT Pin

**EN Pin for Start-Up and Shutdown Operation**

For automatic start-up, the EN pin, with high-voltage rating, can be connected to the input supply  $V_{IN}$  directly. The large built-in hysteresis band makes the EN pin useful for simple delay and timing circuits. The EN pin can be externally connected to  $V_{IN}$  by adding a resistor  $R_{EN}$  and a capacitor  $C_{EN}$ , as shown in Figure 18, to have an additional delay. The time delay can be calculated with the EN's internal threshold, at which switching operation begins (typically 1.25V).

An external MOSFET can be added for the EN pin to be logic-controlled, as shown in Figure 19. In this case, a pull-up resistor,  $R_{EN}$ , is connected between  $V_{IN}$  and the EN pin. The MOSFET Q1 will be under logic control to pull down the EN pin. To prevent the RTQ2117A being enabled when  $V_{IN}$  is smaller than the  $V_{OUT}$  target level or some other desired voltage level, a resistive divider ( $R_{EN1}$  and  $R_{EN2}$ ) can be used to externally set the input under-voltage lockout threshold, as shown in Figure 20.

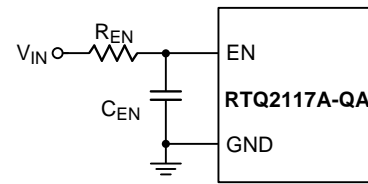

Figure 18. Enable Timing Control

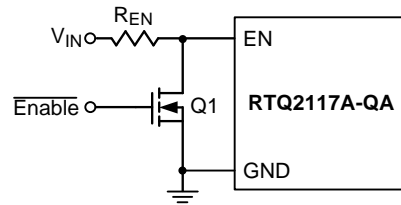

Figure 19. Logic Control for the EN Pin

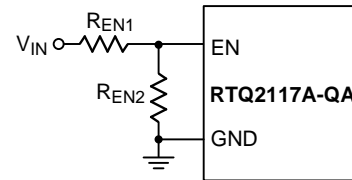

Figure 20. Resistive Divider for Under-Voltage Lockout Threshold Setting

**Soft-Start**

The RTQ2117A provides adjustable soft-start function. The soft-start function is used to prevent large inrush current while converter is being powered-up. For the RTQ2117A, the soft-start timing can be programmed by the external capacitor  $C_{SS}$  between SS pin and GND. An internal current source  $I_{SS}$  ( $6\mu A$ ) charges an external capacitor to build a soft-start ramp voltage. The  $V_{FB}$  will track the internal ramp voltage during soft start interval. The typical soft start time ( $t_{SS}$ ) which is  $V_{OUT}$  rise from zero to 90% of setting value is calculated as follows :

$$t_{SS} = C_{SS} \times \frac{0.8}{I_{SS}}$$

If a heavy load is added to the output with large capacitance, the output voltage will never enter regulation because of UVP. Thus, the RTQ2117A remains in hiccup operation. The  $C_{SS}$  should be large enough to ensure soft-start period ends after  $C_{OUT}$  is fully charged.

$$C_{SS} \geq C_{OUT} \times \frac{I_{SS} \times V_{OUT}}{0.8 \times I_{C_{OUT\_CHG}}}$$

where  $I_{COUT\_CHG}$  is the  $C_{OUT}$  charge current which is related to the switching frequency, inductance, high-side MOSFET switch peak current limit and load current.

### Power-Good Output

The PGOOD pin is an open-drain power-good indication output and is to be connected to an external voltage source through a pull-up resistor.

The external voltage source can be an external voltage supply below 5.5V,  $V_{CC}$  or the output of the RTQ2117A if the output voltage is regulated under 5.5V. It is recommended to connect a 100k $\Omega$  between an external voltage source to PGOOD pin.

### Inductor Peak Current Limit Setting

The current limit of high-side MOSFET switch is adjustable by an external resistor connected to the RLIM pin. The recommended resistor value is ranging from 33k $\Omega$  (for typ. 5.5A) to 91k $\Omega$  (for typ. 2.2A) and it is recommended to use 1% tolerance or better and temperature coefficient of 100 ppm or less resistors. When the inductor current reaches the current limit threshold, the COMP voltage will be clamped to limit the inductor current. Inductor current ripple current also should be considered into current limit setting. It recommends setting the current limit minimum is 1.2 times as high as the peak inductor current. Current limit minimum value can be calculate as below :

Current limit minimum =  $(I_{OUT(MAX)} + 1 / 2 \text{ inductor current ripple}) \times 1.2$ . Through external resistor  $R_{LIM}$  connect to RLIM pin to setting the current limit value.

The current limit value below offer approximate formula equation :

$$R_{LIM}(k\Omega) = \frac{178.8}{I_{SET} - 0.2531} - 1$$

Where  $I_{SET}$  is the desire current limit value (A)

The failure modes and effects analysis (FMEA) consideration is also applied to RLIM pin setting to avoid abnormal current limit operation at failure condition. It includes failure scenarios of short-circuit to GND and the pin is left open. The inductor peak current limit will be 6.2A (typically) when the RLIM pin short to GND and 1.4A (typically) when the pin is left open.

Note that the inductor peak current limit variation increases as the tolerance of  $R_{LIM}$  resistor increases. As the  $R_{LIM}$  resistor value is small, the inductor peak current limit will probably be operated as RLIM pin short to GND, and vice versa. The  $R_{LIM}$  resistance variation range is limited from 30k $\Omega$  to 100k $\Omega$  to eliminate the undesired inductor peak current limit. When choosing a  $R_{LIM}$  other than the recommended range, please make sure that there is no problem by evaluating it with real machine.

### Synchronization

The RTQ2117A can be synchronized with an external clock ranging from 300kHz to 2.2MHz which is applied to the MODE/SYNC pin. The external clock duty cycle must be from 20% to 80% and amplitude should have valleys that are below  $V_{IL\_SYNC}$  and peaks above  $V_{IH\_SYNC}$  (up to 6V). The RTQ2117A will not enter PSM operation at light load while synchronized to an external clock, but instead will operate in FPWM to maintain regulation.

### Average Current Limit

The RTQ2117A implements Constant Current Control to achieve average current limit. The constant current of CC mode control is set by external sense resistance ( $R_{SENSE}$ ).

The average current is set according to the following equation :

$$\text{Average Current Limit} = \frac{V_{REF\_CC}}{R_{SENSE}}$$

where the reference voltage of constant current regulation  $V_{REF\_CC}$ , is 100mV (typically) and the  $V_{REF\_CC}$  variation is around  $\pm 10\%$ . The average current limit function is recommended to operate with CSP/CSN voltages range from 3.3 V to 6V.

### Adjustable Output Voltage with Cable Drop

#### Compensation

The RTQ2117A provides cable drop compensation function at CV regulation. If the trace from the RTQ2117A output terminator to the load is too long, there will be a voltage drop on the long trace which is variable with load current. The RTQ2117A is capable of compensating the output voltage drop to keep a

constant voltage at load, whatever the load current is.

The compensation voltage ( $V_{O\_OFFSET}$ ) is based on cable drop compensation current ( $I_{LC}$ ) and divide upper side resistor R1, which can be calculated as following formula :

$$V_{O\_OFFSET} = I_{LC} \times R1$$

The cable drop compensation current variation is  $\pm 10\%$ , and it is a function of current sense voltage ( $V_{CS}$ ) :

$$I_{LC} (\mu A) = 21 \times (V_{CS} - 0.00476)$$

where current sense voltage is the voltage difference between CSP pin and CSN pin, that is the voltage across a current sense resistor ( $R_{SENSE}$ ). The Figure 21 shows the relationship between cable drop compensation current ( $I_{LC}$ ) and  $V_{CS}$ .

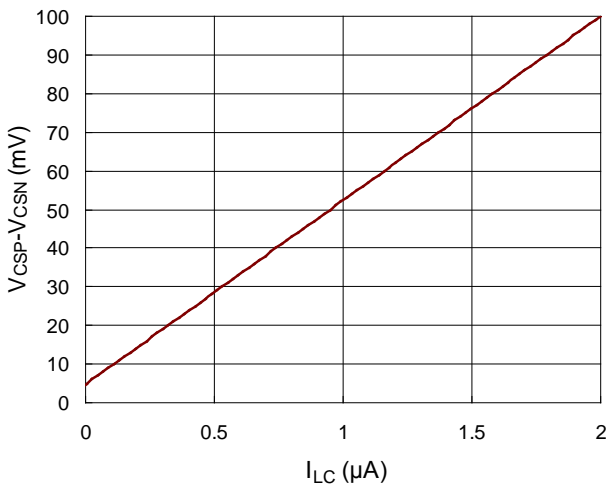

Figure 21.  $I_{LC}$  vs.  $V_{CSP} - V_{CSN}$

According to the formula above, the desired compensation voltage which is set at rated output current can be calculated as below

$$V_{O\_OFFSET} = 21 \times (R_{SENSE} \times I_{OUT} - 0.00476) \times 10^{-6} \times R1$$

Where  $I_{OUT}$  is the rated output current.

Choose the  $R_{SENSE}$  with rated load current and reserve some de-rating margin for better thermal and life consideration. In order to avoid the undesired CC control loop interruption, the current sense voltage is selected should be the lower value of 100mV. If the system implements constant current control to achieve average current limit, the  $R_{SENSE}$  is set based on the

average current limit equation.

Considering CV regulation with cable drop compensation situation, the desire cable drop compensation is 0.24V at rated 2.4A loading and  $R_{SENSE}$  is selected as 34m $\Omega$ , the R1 can be calculated as below :

$$R1 = \frac{V_{O\_OFFSET}}{21 \times (R_{SENSE} \times I_{OUT} - 0.00476) \times 10^{-6}} = 148.7k\Omega$$

Select 147k $\Omega$  for R1. The resistance of R2 can then be obtained as below :

$$R2 = \frac{R1 \times V_{REF\_CV}}{V_{OUT} - V_{REF\_CV}} = 28k\Omega$$

In this case, 147k $\Omega$  is available for resistance of R1 and 28k $\Omega$  is available for resistance of R2. The R1 and R2 values can be calculated based on above equation. If the R1 and R2 values are too high, the regulator will be more susceptible to noise and voltage errors from the FB input current will be noticeable. Make sure the current flowing through the FB resistive divider is larger than  $5 \times 10^{-6}$ . In addition, a feed-forward capacitor  $C_{FF}$  may be required to improve output voltage ripple at PSM.

The power dissipation on sensing resistor will be :

$$P_{RSENSE} = R_{SENSE} \times I_{OUT}^2 = 306mW$$

Choose current sense resistor power rated with 50% de-rating rule of thumb for better heat and life consideration, 1W size is well enough for this case. Hence, the 34m $\Omega$ , 1W size  $R_{SENSE}$  is determined and with aid of the cable drop compensation feature, the RTQ2117A can compensate the 0.24V voltage drop to maintain excellent output voltage accuracy at rated 2.4A load current. Note that the  $R_{SENSE}$  should be connected as close to the CSP/CSN with short, direct traces, creating Kelvin connection to ensure that noise and current sense voltage errors do not corrupt the differential current sense signals between the CS and VOUT pins. The cable drop compensation function is recommended to operate with CSP/CSN voltages range from 3.3 V to 6V.

## Battery Charging Mode Control

USB Battery Charging Specification BC1.2 lists three different port types: Standard Downstream Port (SDP), Charging Downstream Port (CDP) and Dedicated Charging Port (DCP). The RTQ2117A supports USB BC1.2 SDP/CDP and DCP auto-detect Mode and set by BCM pin.

### Standard Downstream Port (SDP) USB 2.0/USB 3.0

An SDP is a traditional USB port that follows USB 2.0/3.0 protocol, and supplies a maximum of 500mA for USB 2.0 and 900mA for USB 3.0 per port. Communication through USB data lines is supported, and the host controller must be active to allow charging.

### Charging Downstream Port (CDP)

A CDP is a USB port that follows USB BC1.2 and supplies a minimum of 1.5A current. It provides power and meets USB 2.0 requirements for device enumeration. USB 2.0 communications is supported, and the host controller must be active to allow charging. What separates a CDP from an SDP is the host-charge handshaking logic that identifies this port as a CDP. A CDP is identifiable by a compliant BC1.2 client device, and allows for additional current draw by the client device.

### DCP Auto Mode

The DCP Auto Mode only provides power but does not support data connection to an upstream port. The RTQ2117A integrates an auto-detect state machine.

that supports all the DCP charging schemes listed below :

- ▶ Shorted
- ▶ Divider 3
- ▶ 1.2V shorted

Shorted mode complies with BC1.2 DCP and Chinese Telecommunications Industry Standard YD/T 1591-2009, defining that the D+/D- data lines should be shorted together with a maximum series impedance of 200Ω.

In Divider3 charging scheme the device applies 2.7V/2.7V to D+/D- data lines.

1.2V shorted charging scheme applies 1.2V to the shorted D+/D- data lines.

The DCP auto mode starts in Divider 3 Mode, however if a BC1.2 or YD/T 1591-2009 compliant device is attached, it responds by operating in BC1.2 shorted mode briefly then moves to 1.2V shorted mode. The complete detection Flow as shown in Figure 22.

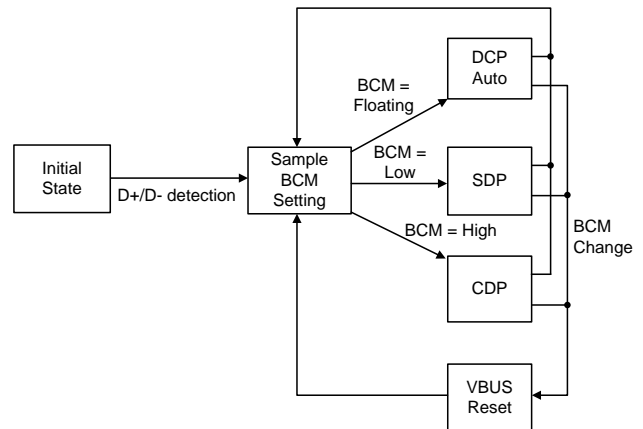

Figure 22. Detection Flow

### CDP/SDP Auto Switch

The RTQ2117A is equipped with a CDP/SDP auto-switch feature to support some popular phones in the market that are not compliant to the BC1.2 specification, as they fail to establish data connection in CDP mode. These phones use primary detection (used to distinguish between an SDP and different types of Charging Ports) to only identify ports as SDP or DCP. They do not recognize CDP ports. When connected to a CDP port, these phones classify the port as a DCP and only charges. To fix this problem, the RTQ2117A employs a CDP/SDP Auto Switch scheme to ensure these BC1.2 non-compliant phones establishes data connection.

### Thermal Considerations

In many applications, the RTQ2117A does not generate much heat due to its high efficiency and low thermal resistance of its WETD-VQFN-32L 5x5 package. However, in applications in which the RTQ2117A is running at a high ambient temperature and high input voltage or high switching frequency, the

generated heat may exceed the maximum junction temperature of the part.

The junction temperature should never exceed the absolute maximum junction temperature  $T_{J(MAX)}$ , listed under Absolute Maximum Ratings, to avoid permanent damage to the RTQ2117A. If the junction temperature reaches approximately 175°C, the RTQ2117A stop switching the power MOSFETs until the temperature drops about 15°C cooler.

The maximum power dissipation can be calculated by the following formula :

$$P_{D(MAX)} = (T_{J(MAX)} - T_A) / \theta_{JA(EFFECTIVE)}$$

where  $T_{J(MAX)}$  is the maximum allowed junction temperature of the die. For recommended operating condition specifications, the maximum junction temperature is 150°C.  $T_A$  is the ambient operating temperature,  $\theta_{JA(EFFECTIVE)}$  is the system-level junction to ambient thermal resistance. It can be estimated from thermal modeling or measurements in the system.

The RTQ2117A thermal resistance depends strongly on the surrounding PCB layout and can be improved by providing a heat sink of surrounding copper ground. The addition of backside copper with thermal vias, stiffeners, and other enhancements can also help reduce thermal resistance.

Experiments in the Richtek thermal lab show that simply set  $\theta_{JA(EFFECTIVE)}$  as 110% to 120% of the  $\theta_{JA}$  is reasonable to obtain the allowed  $P_{D(MAX)}$ .

As an example, consider the case when the RTQ2117A is used in applications where  $V_{IN} = 12V$ ,  $I_{OUT} = 2.4A$ ,  $f_{SW} = 2100kHz$ ,  $V_{OUT} = 5V$ . The efficiency at 5V, 2.4A is 89% by using Cyntec-VCHA075D-2R2MS6 (2.2μH, 9.5mΩ DCR) as the inductor and measured at room temperature. The core loss can be obtained from its website of 18.8mW in this case. In this case, the power dissipation of the RTQ2117A is

$$P_{D, RT} = \frac{1-\eta}{\eta} \times P_{OUT} - (I_O^2 \times DCR + P_{CORE}) = 1.41W$$

Considering the  $\theta_{JA(EFFECTIVE)}$  is 50.9°C/W by using the RTQ2117A evaluation board with 4 layers PCB, 10Z for all layers. The junction temperature of the regulator operating in a 25°C ambient temperature is approximately :

$$T_J = 1.41W \times 50.9°C/W + 25°C = 96.7°C$$

Figure 23 shows the RTQ2117A  $R_{DS(ON)}$  versus different junction temperature. If the application calls for a higher ambient temperature, we might recalculate the RTQ2117A power dissipation and the junction temperature based on a higher  $R_{DS(ON)}$  since it increases with temperature.

Using 50°C ambient temperature as an example, the change of the equivalent  $R_{DS(ON)}$  can be obtained from Figure 23 and yields a new power dissipation of 1.467W. Therefore, the estimated new junction temperature is

$$T_J' = 1.467W \times 50.9°C/W + 50°C = 124.7°C$$

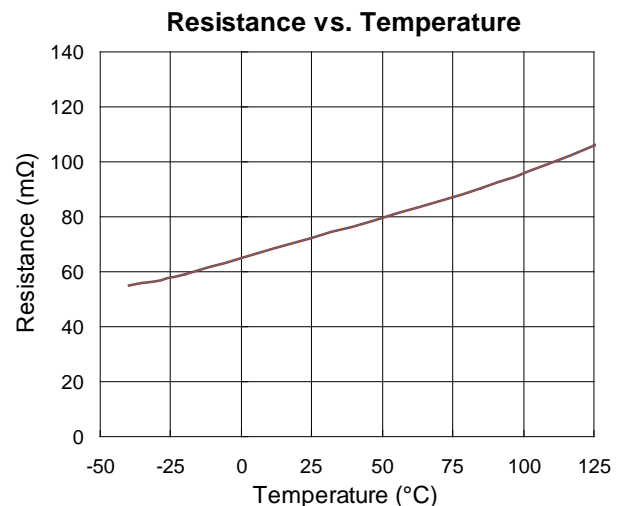

Figure 23. Resistance Variation Curve at Different Temperature

**Layout Considerations**

When laying out the printed circuit board, the following checklist should be used to ensure proper operation of the RTQ2117A :

- ▶ Four-layer or six-layer PCB with maximum ground plane is strongly recommended for good thermal performance.

- ▶ Keep the traces of the main current paths wide and short.
  - ▶ Place high frequency decoupling capacitor  $C_{IN3}$  as close as possible to the IC to reduce the loop impedance and minimize switch node ringing.
  - ▶ Place the  $C_{VCC}$  as close to VCC pin as possible.
  - ▶ Place bootstrap capacitor,  $C_{BOOT}$ , as close to IC as possible. Routing the trace with width of 20mil or wider.
  - ▶ Place multiple vias under the RTQ2117A near VIN and PGND and near input capacitors to reduce parasitic inductance and improve thermal performance. To keep thermal resistance low, extend the ground plane as much as possible, and add thermal vias under and near the RTQ2117A to additional ground planes within the circuit board and on the bottom side.
  - ▶ The high frequency switching nodes, SW and BOOT, should be as small as possible. Keep analog components away from the SW and BOOT nodes.
  - ▶ Reducing the area size of the SW exposed copper to reduce the electrically coupling from this voltage.
  - ▶ Connect the feedback sense network behind via of output capacitor.
  - ▶ Place the feedback components near the IC.
  - ▶ Place the compensation components near the IC.
  - ▶ Connect all analog grounds to common node and then connect the common node to the power ground with a single point.
  - ▶ Minimize current sense voltage errors by using Kelvin connection for PCB routing of the CSP pin, CSN pin and current sense resistor ( $R_{SENSE}$ ).
- Figure 24 to Figure 27 are the layout example.



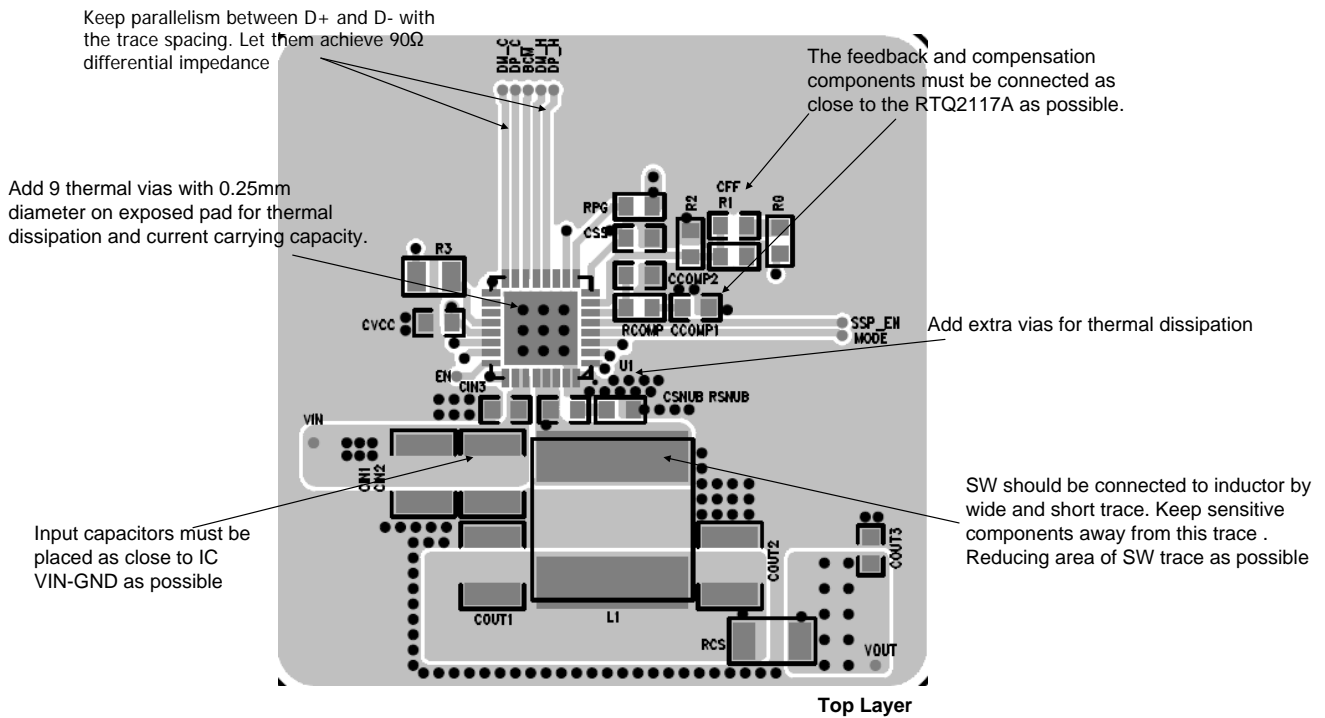

Figure 24. Layout Guide (Top Layer)



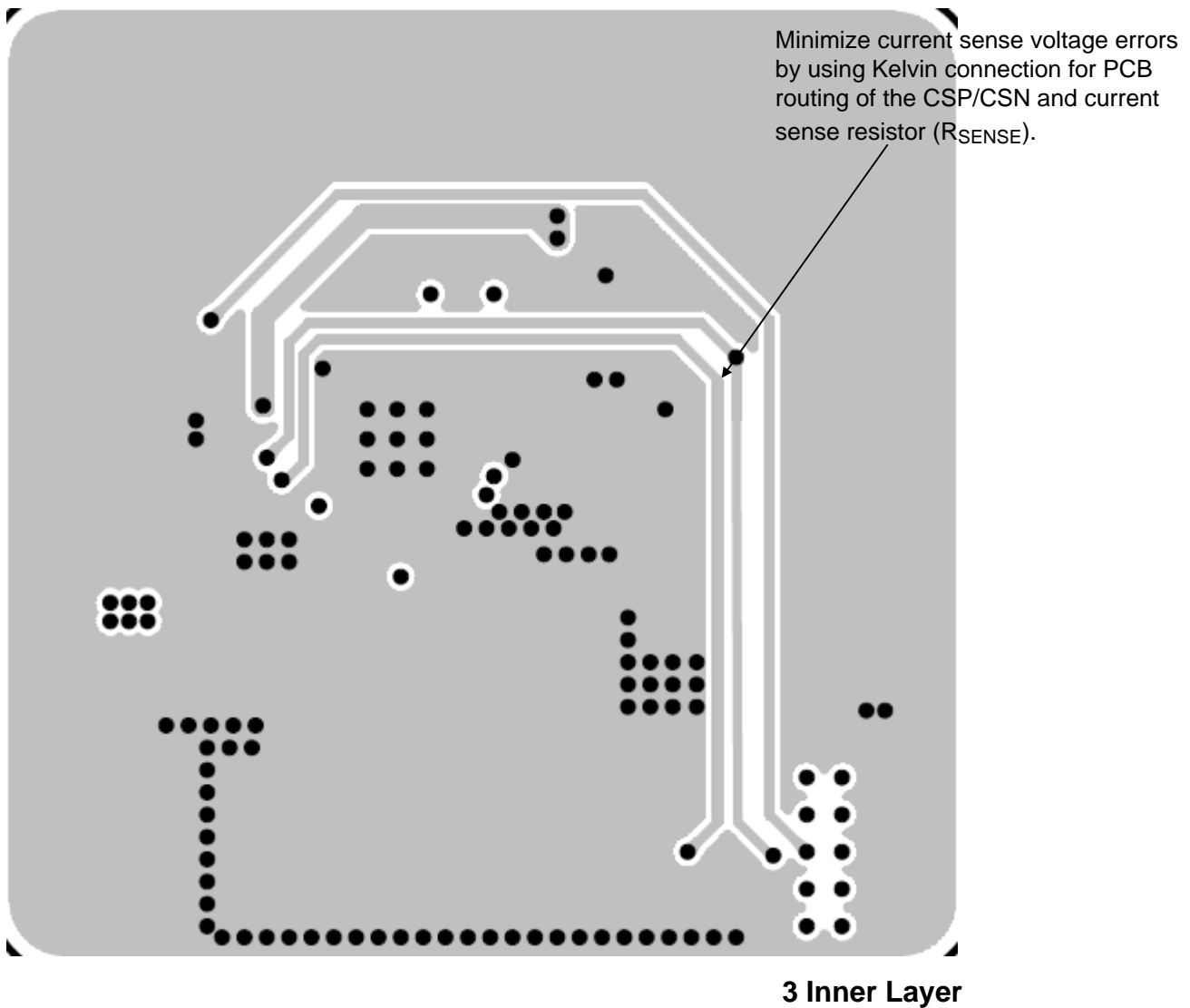

Figure 26. Layout Guide (3 Inner Layer)

Keep analog components away from the BOOT nodes.

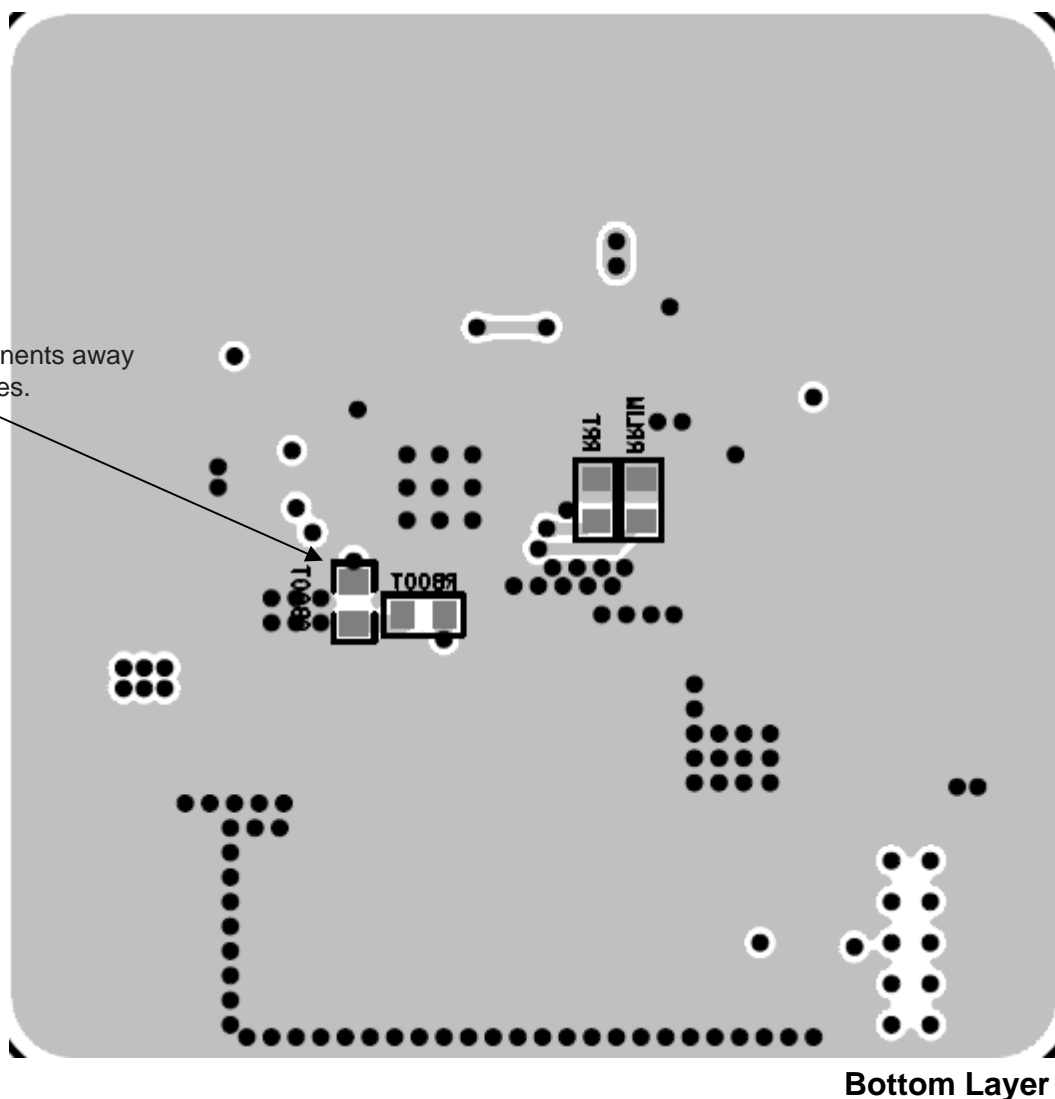
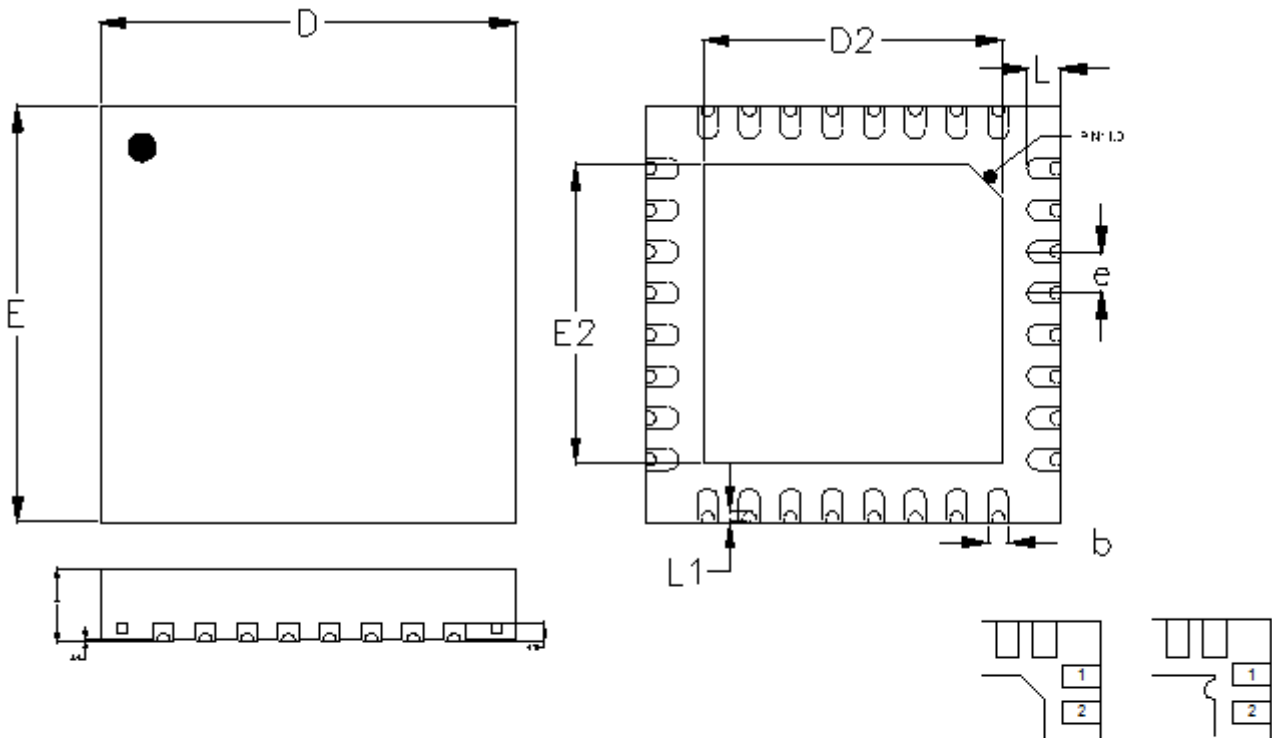

Figure 27. Layout Guide (Bottom Layer)

**Outline Dimension**



**DETAIL A**

Pin #1 ID and Tie Bar Mark Options

Note : The configuration of the Pin #1 identifier is optional, but must be located within the zone indicated.

Symbol	Dimensions In Millimeters		Dimensions In Inches	
	Min	Max	Min	Max
A	0.800	1.000	0.031	0.039
A1	0.000	0.050	0.000	0.002
A3	0.175	0.250	0.007	0.010
b	0.180	0.300	0.007	0.012
D	4.950	5.050	0.195	0.199
D2	3.550	3.650	0.140	0.144
E	4.950	5.050	0.195	0.199
E2	3.550	3.650	0.140	0.144
e	0.500		0.020	
L	0.350	0.450	0.014	0.018
L1	0.075	0.175	0.003	0.007

**WETD V-Type 32L QFN 5x5 Package**

Footprint Information

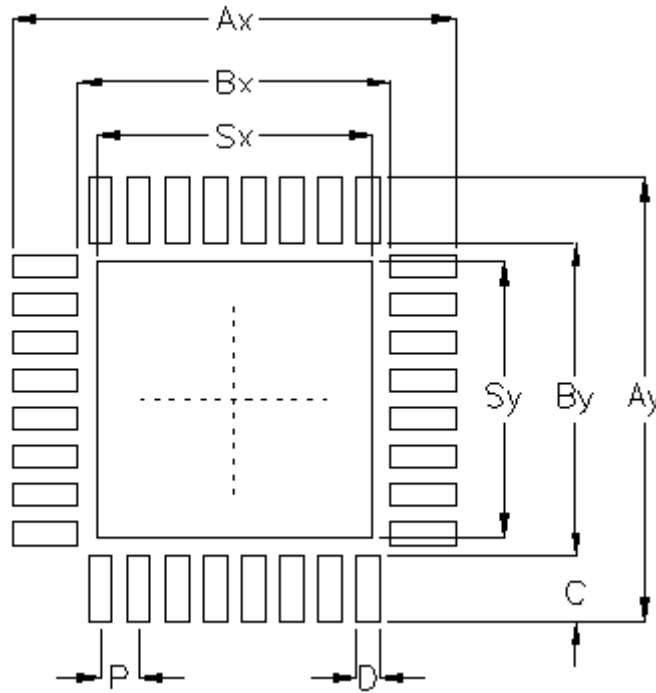

Package	Number of Pin	Footprint Dimension (mm)									Tolerance
		P	Ax	Ay	Bx	By	C	D	Sx	Sy	
WETD-V/W/U/XQFN5x5-32	32	0.50	5.80	5.80	4.10	4.10	0.85	0.30	3.60	3.60	±0.05

Richtek Technology Corporation

14F, No. 8, Tai Yuen 1<sup>st</sup> Street, Chupei City  
 Hsinchu, Taiwan, R.O.C.  
 Tel: (8863)5526789

RICHTEK

Richtek products are sold by description only. Richtek reserves the right to change the circuitry and/or specifications without notice at any time. Customers should obtain the latest relevant information and data sheets before placing orders and should verify that such information is current and complete. Richtek cannot assume responsibility for use of any circuitry other than circuitry entirely embodied in a Richtek product. Information furnished by Richtek is believed to be accurate and reliable. However, no responsibility is assumed by Richtek or its subsidiaries for its use; nor for any infringements of patents or other rights of third parties which may result from its use. No license is granted by implication or otherwise under any patent or patent rights of Richtek or its subsidiaries.

Copyright © 2021 Richtek Technology Corporation. All rights reserved. RICHTEK is a registered trademark of Richtek Technology Corporation.

www.richtek.com

DSQ2117A-QA-01 July 2021

单击下面可查看定价，库存，交付和生命周期等信息

[>>Richtek\(台湾立锜\)](#)