

1 μ A I_Q, 250mA Low-Dropout Linear Regulator

Purpose

The RT9073 is a low-dropout (LDO) voltage regulators with enable function that operates from 1.2V to 5.5V. It provides up to 250mA of output current and offers low-power operation in miniaturized packaging.

The features of low quiescent current as low as 1 μ A and almost zero disable current is ideal for powering the battery equipment to a longer service life. The RT9073 is stable with the ceramic output capacitor over its wide input range from 1.2V to 5.5V and the entire range of output load current (0mA to 250mA).

Table of Contents

Purpose.....	1
Introduction	2
Key Performance Summary Table	2
Bench Test Setup Conditions.....	3
Schematic, Bill of Materials & Board Layout.....	4
More Information.....	6
Important Notice for Richtek Evaluation Board.....	6

Introduction

General Product Information

The RT9073 is a low quiescent current linear regulator designed especially for low external components system. The input voltage range is from 1.2V to 5.5V. The RT9073 builds in a P-MOSFET output transistor which provides a low switch-on resistance for low dropout voltage applications.

The Error Amplifier compares the internal reference voltage with the output feedback voltage from the internal divider, and controls the Gate voltage of P-MOSFET to support good line regulation and load regulation at output voltage.

Product Feature

- 1 μ A Ground Current at no Load
- PSRR = 75dB at 1kHz
- Adjustable Output Voltage Available by Specific Application
- \pm 2% Output Accuracy
- 250mA ($V_{IN} \geq 2.3V$) Output Current with EN
- Low (0.1 μ A) Disable Current
- 1.2V to 5.5V Operating Input Voltage
- Dropout Voltage : 0.5V at 250mA when $V_{OUT} \geq 3V$
- Support Fixed Output Voltage 3.3V
- Stable with Ceramic or Tantalum Capacitor
- Current Limit Protection
- Over Temperature Protection
- SOT-23-5 Packages Available

Key Performance Summary Table

Key Features	Evaluation Board Number : PCB041_V1
Input Voltage Range	1.2V to 5.5V
Output Current Limit	350mA
Power Supply Rejection Ratio	75dB
Default Marking & Package Type	RT9073N-33GB, SOT-23-5
VCC Consumption Current	1 μ A

Bench Test Setup Conditions

Headers Description and Placement

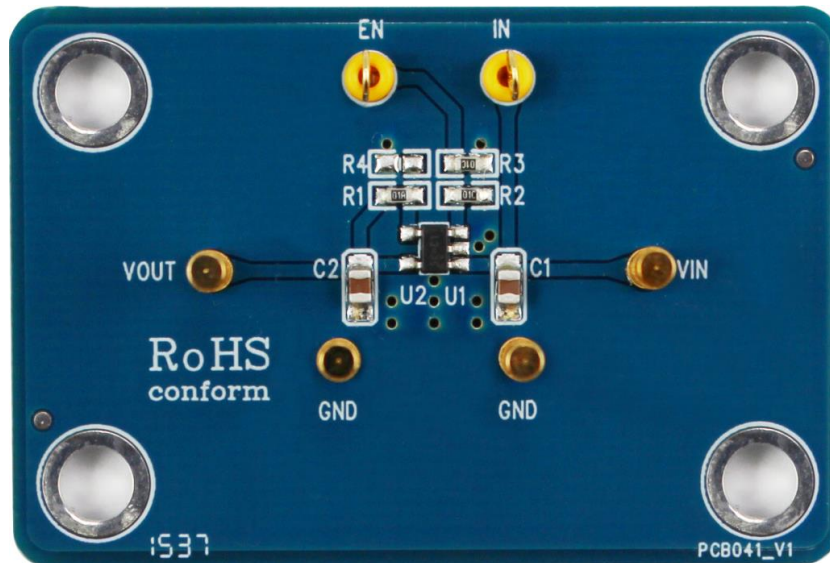

Please carefully inspect the EVB IC and external components, comparing them to the following Bill of Materials, to ensure that all components are installed and undamaged. If any components are missing or damaged during transportation, please contact the distributor or send e-mail to evb_service@richtek.com

Test Points

The EVB is provided with the test points and pin names listed in the table below.

Test point/ Pin name	Signal	Comment (expected waveforms or voltage levels on test points)
VIN	Input voltage	Input voltage range = 1.2V to 5.5V.
GND	Ground	Ground.
EN	Enable	Enable Control Input.
SNS	Output Voltage Sense point	Output Voltage Sense.
NC	NC	No Internal Connection. (RT9073N only).
VOUT	Output voltage	Default output voltage = 3.3V

Power-up & Measurement Procedure

1. Connect input power ($1.2V < V_{IN} < 5.5V$) to VIN test pin.
2. VIN/VOUT placed 1 μ F capacitor.
3. Observe the output voltage is correct.

Schematic, Bill of Materials & Board Layout

EVB Schematic Diagram

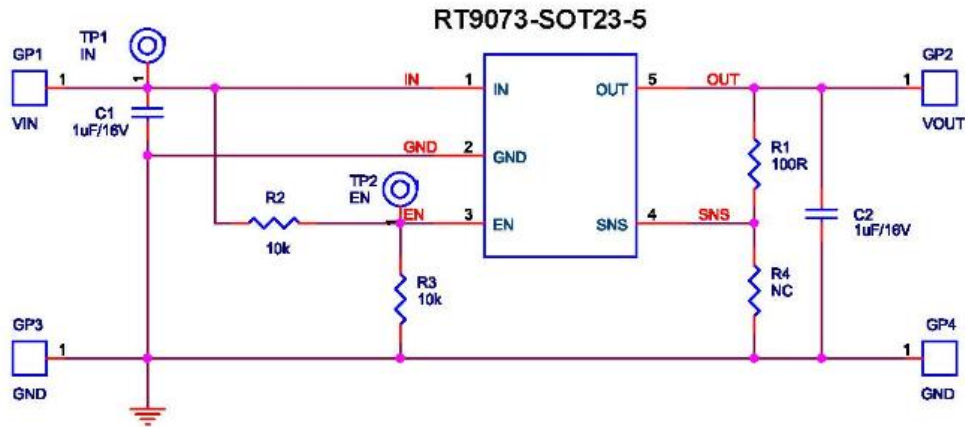

Bill of Materials

Reference	Qty	Part Number	Description	Package	Manufacture
U1	1	RT9073N-33GB	Single Output LDO	SOT-23-5	Richtek
C1,C2	2	C2012X7R1E105KT00HN	1μF/25V	C-0805	TDK
GP1	1		VIN	SIP-1P-GP	
GP2	1		VOUT	SIP-1P-GP	
GP3, GP4	2		GND	SIP-1P-GP	
R1	1	WR06X1000F	100R	R-0603	WALSIN
R2, R3	2	WR06X1002F	10k	R-0603	WALSIN
R4	1		NC	R-0603	
TP1	1		IN	SIP-1P-TP	
TP2	1		EN	SIP-1P-TP	
Z1, Z2, Z3, Z4	4		SIP-1P-M	SIP-1P-M	
Z5, Z6	2		FK_1	FK_1	

PCB Layout

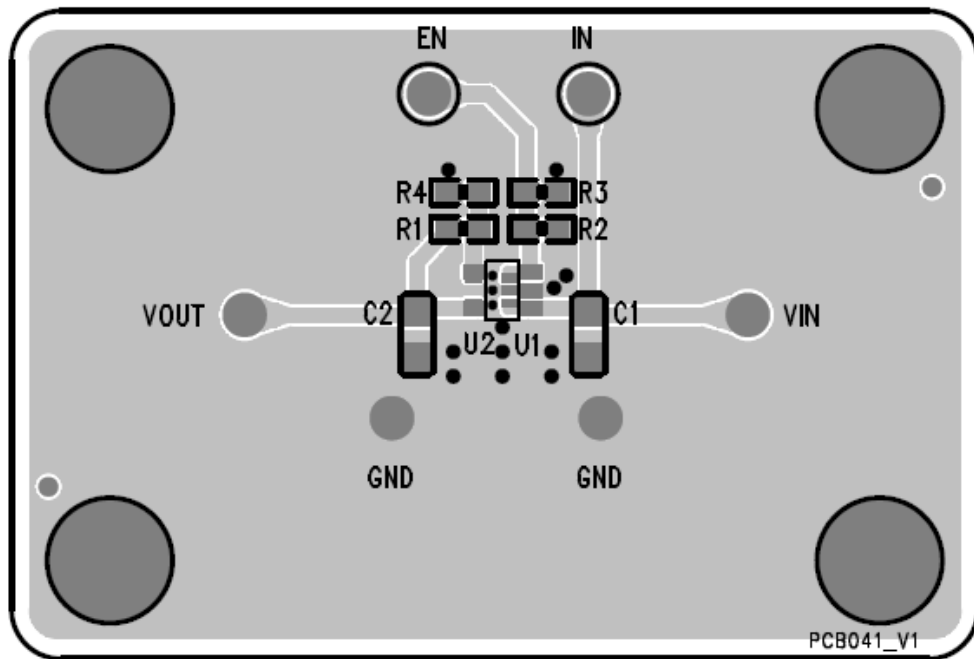

Top View

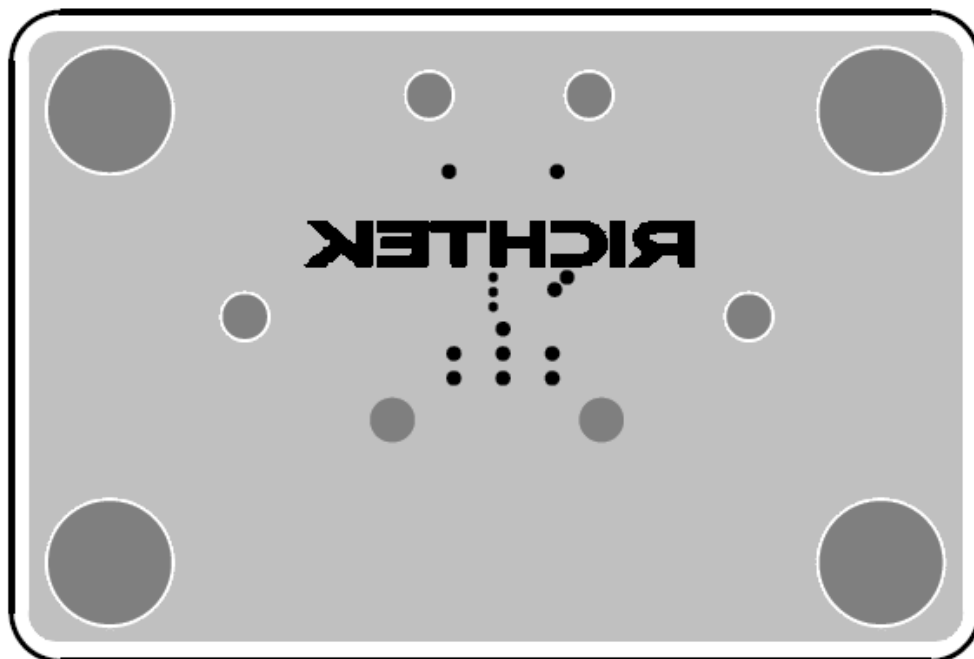

Bottom View

More Information

For more information, please find the related datasheet or application notes from Richtek website <http://www.richtek.com>.

Important Notice for Richtek Evaluation Board

THIS DOCUMENT IS FOR REFERENCE ONLY, NOTHING CONTAINED IN THIS DOCUMENT SHALL BE CONSTRUED AS RICHTEK'S WARRANTY, EXPRESS OR IMPLIED, UNDER CONTRACT, TORT OR STATUTORY, WITH RESPECT TO THE PRESENTATION HEREIN. IN NO EVENT SHALL RICHTEK BE LIABLE TO BUYER OR USER FOR ANY AND ALL DAMAGES INCLUDING WITHOUT LIMITATION TO DIRECT, INDIRECT, SPECIAL, PUNITIVE OR CONSEQUENTIAL DAMAGES.

单击下面可查看定价，库存，交付和生命周期等信息

[>>Richtek\(台湾立锜\)](#)