

## 2A, 24V, 400kHz Step-Down Converter

### General Description

The RT8268 is a high voltage buck converter that can support the input voltage range from 4.75V to 24V and the output current can be up to 2A. Current Mode operation provides fast transient response and eases loop stabilization. The RT8268 also provides adjustable soft-start to be a flexible solution for customers.

The chip provides protection functions such as cycle-by-cycle current limiting and thermal shutdown protection. In shutdown mode, the regulator draws 22μA of supply current. The RT8268 is available in the SOP-8 and MSOP-10 (Exposed Pad) surface mount package.

### Ordering Information

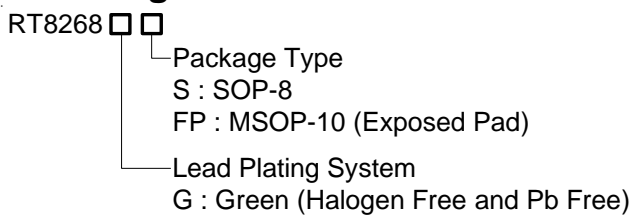

Note :

Richtek products are :

- ▶ RoHS compliant and compatible with the current requirements of IPC/JEDEC J-STD-020.
- ▶ Suitable for use in SnPb or Pb-free soldering processes.

### Marking Information

For marking information, contact our sales representative directly or through a Richtek distributor located in your area.

### Features

- **Wide Operating Input Range : 4.75V to 24V**
- **Adjustable Output Voltage Range : 0.92V to 16V**
- **Output Current up to 2A**
- **22μA Low Shutdown Current**
- **Power MOSFET : 0.18Ω**
- **High Efficiency up to 95%**
- **400kHz Fixed Switching Frequency**
- **Stable with Low ESR Output Ceramic Capacitors**
- **Programmable Soft-Start**
- **Thermal Shutdown Protection**
- **Cycle-By-Cycle Over Current Protection**
- **RoHS Compliant and Halogen Free**

### Applications

- Distributive Power Systems
- Battery Charger
- DSL Modems
- Pre-regulator for Linear Regulators

### Pin Configurations

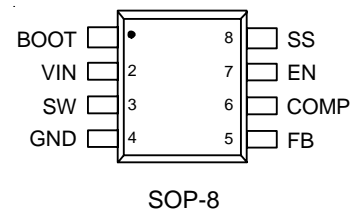
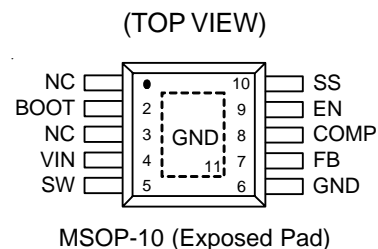

Typical Application Circuit

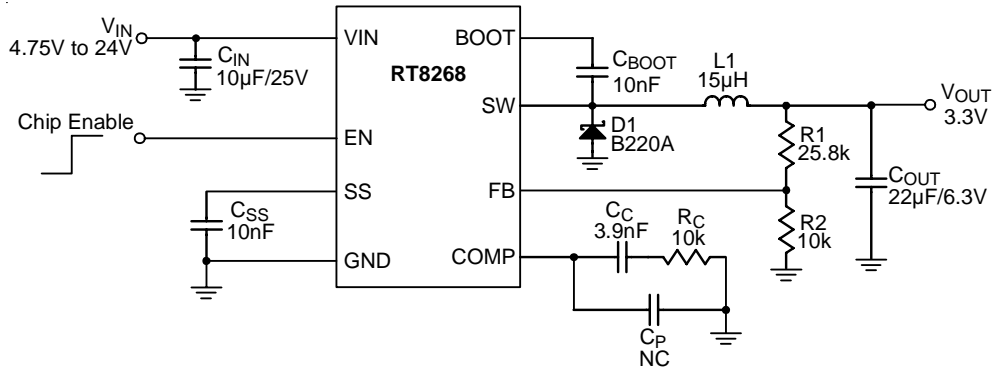
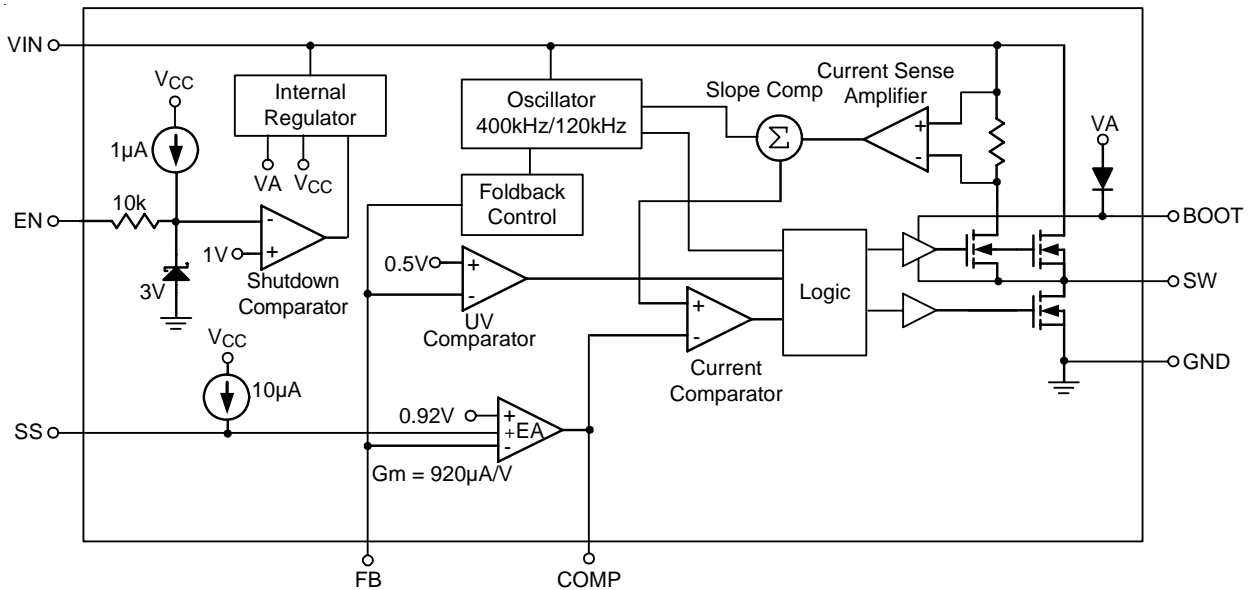

Table 1. Recommended Component Selection

$V_{OUT}$ (V)	$R_1$ (k $\Omega$ )	$R_2$ (k $\Omega$ )	$R_C$ (k $\Omega$ )	$C_C$ (nF)	$L_1$ ( $\mu$ H)	$C_{OUT}$ ( $\mu$ F)
15	153	10	48.7	0.82	33	22
10	100	10	34	1.2	33	22
8	76.8	10	24	1.5	22	22
5	44.2	10	16	2.2	22	22
3.3	25.8	10	10	3.9	15	22
2.5	17	10	7.5	1.5	10	22
1.8	9.31	10	6.04	1.5	10	22
1.2	3	10	6.04	3.9	6.8	22

Function Block Diagram



**Functional Pin Description**

Pin No.		Pin Name	Pin Function
PMSOP-10	SOP-8		
1, 3	--	NC	No Internal Connection.
2	1	BOOT	High Side Gate Drive Bootstrap Input. BOOT supplies the drive for the high side N-MOSFET switch. Connect a 10nF or greater capacitor from SW to BOOT to power the high side switch.
4	2	VIN	Power Input. $V_{IN}$ supplies the power to the IC, as well as the step-down converter switches. Bypass VIN to GND with a suitable large capacitor to eliminate noise on the input to the IC.
5	3	SW	Power Switching Output. SW is the switching node that supplies power to the output. Connect the output LC filter from SW to the output load. Note that a capacitor is required from SW to BOOT to power the high side switch.
6, 11 (Exposed Pad)	4	GND	Ground. The exposed pad must be soldered to a large PCB and connected to GND for maximum power dissipation.
7	5	FB	Feedback Input. FB senses the output voltage to regulate said voltage. The feedback reference voltage is 0.92V typically.
8	6	COMP	Compensation Node. COMP is used to compensate the regulation control loop. Connect a series RC network from COMP to GND to compensate the regulation control loop. In some cases, an additional capacitor from COMP to GND is required.
9	7	EN	Enable Input. EN is a digital input that turns the regulator on or off. Drive EN higher than 1.4V to turn on the regulator, lower than 0.4V to turn it off. If the EN pin is open, it will be pulled to high by internal circuit.
10	8	SS	Soft-Start Control Input. SS controls the soft start period. Connect a capacitor from SS to GND to set the soft-start period. A 10nF capacitor sets the soft-start period to 1ms.

**Absolute Maximum Ratings** (Note 1)

- Supply Voltage,  $V_{IN}$  ----- -0.3V to 26V
- Switching Voltage,  $V_{SW}$  ----- -0.3V to ( $V_{IN} + 0.3V$ )
- BOOT Voltage ----- ( $V_{SW} - 0.3V$ ) to ( $V_{SW} + 6V$ )
- All Other Voltage ----- -0.3V to 6V
- Power Dissipation,  $P_D$  @  $T_A = 25^\circ C$ 
  - SOP-8 ----- 0.833W
  - MSOP-10 (Exposed Pad) ----- 1.163W
- Package Thermal Resistance (Note 2)
  - SOP-8,  $\theta_{JA}$  ----- 120°C/W
  - MSOP-10 (Exposed Pad),  $\theta_{JA}$  ----- 86°C/W
  - MSOP-10 (Exposed Pad),  $\theta_{JC}$  ----- 30°C/W
- Junction Temperature ----- 150°C
- Lead Temperature (Soldering, 10 sec.) ----- 260°C
- Storage Temperature Range ----- -65°C to 150°C
- ESD Susceptibility (Note 3)
  - HBM (Human Body Mode) ----- 2kV
  - MM (Machine Mode) ----- 200V

**Recommended Operating Conditions** (Note 4)

- Supply Voltage,  $V_{IN}$  ----- 4.75V to 24V
- Enable Voltage,  $V_{EN}$  ----- 0V to 5.5V
- Junction Temperature Range ----- -40°C to 125°C
- Ambient Temperature Range ----- -40°C to 85°C

**Electrical Characteristics**

( $V_{IN} = 12V$ ,  $T_A = 25^\circ C$  unless otherwise specified)

Parameter	Symbol	Test Conditions	Min	Typ	Max	Unit
Feedback Reference Voltage	$V_{FB}$	$4.75V \leq V_{IN} \leq 24V$	0.902	0.92	0.938	V
High Side Switch-On Resistance	$R_{DS(ON)1}$		--	0.18	--	$\Omega$
Low Side Switch-On Resistance	$R_{DS(ON)2}$		--	10	--	$\Omega$
Switch Leakage		$V_{EN} = 0V$ , $V_{SW} = 0V$	--	--	10	$\mu A$
Current Limit	$I_{LIM}$	Duty = 90%; $V_{BOOT-SW} = 4.8V$	--	3	--	A
Current Sense Transconductance	$G_{CS}$	Output Current to $V_{COMP}$	--	2.5	--	A/V
Error Amplifier Tansconductance	$G_m$	$\Delta I_C = \pm 10\mu A$	620	920	1220	$\mu A/V$
Oscillator Frequency	$f_{SW}$		--	400	--	kHz
Short Circuit Oscillation Frequency		$V_{FB} = 0V$	--	120	--	kHz
Maximum Duty Cycle	$D_{MAX}$	$V_{FB} = 0.8V$	--	90	--	%
Minimum On-Time	$t_{ON}$		--	90	--	ns
Under Voltage Lockout Threshold Rising			3.8	4.2	4.5	V
Under Voltage Lockout Threshold Hysteresis			--	250	--	mV

To be continued

Parameter	Symbol	Test Conditions	Min	Typ	Max	Unit
En input Low Voltage			--	--	0.4	V
En input High Voltage			1.4	--	5.5	V
Enable Pull-up Current		$V_{EN} = 0V$	--	1	--	$\mu A$
Shutdown Current	$I_{SHDN}$	$V_{EN} = 0V$	--	22	36	$\mu A$
Quiescent Current	$I_Q$	$V_{EN} = 2V, V_{FB} = 1V$	--	0.6	1	mA
Soft-Start Period		$C_{SS} = 10nF$	--	1	--	ms
Thermal Shutdown	$T_{SD}$		--	150	--	$^{\circ}C$

**Note 1.** Stresses listed as the above "Absolute Maximum Ratings" may cause permanent damage to the device. These are for stress ratings. Functional operation of the device at these or any other conditions beyond those indicated in the operational sections of the specifications is not implied. Exposure to absolute maximum rating conditions for extended periods may remain possibility to affect device reliability.

**Note 2.**  $\theta_{JA}$  is measured in the natural convection at  $T_A = 25^{\circ}C$  on a high effective thermal conductivity four layers test board of JEDEC 51-7 thermal measurement standard. The case point of  $\theta_{JC}$  is on the expose pad for MSOP-10 (Exposed Pad) package.

**Note 3.** Devices are ESD sensitive. Handling precaution is recommended.

**Note 4.** The device is not guaranteed to function outside its operating conditions.

Typical Operating Characteristics

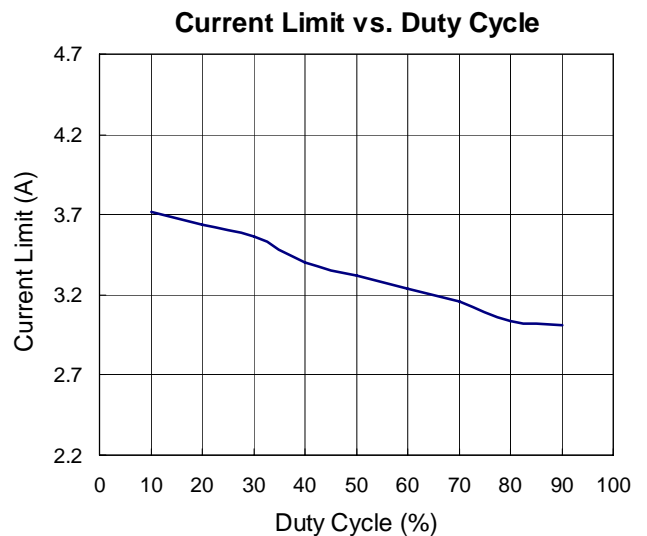
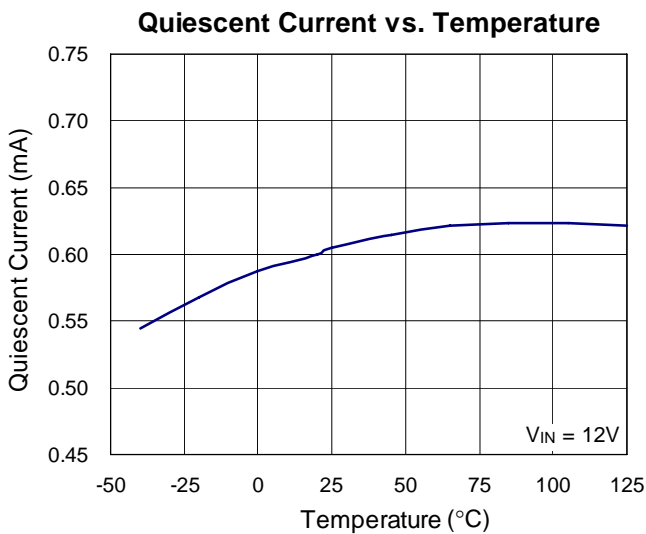
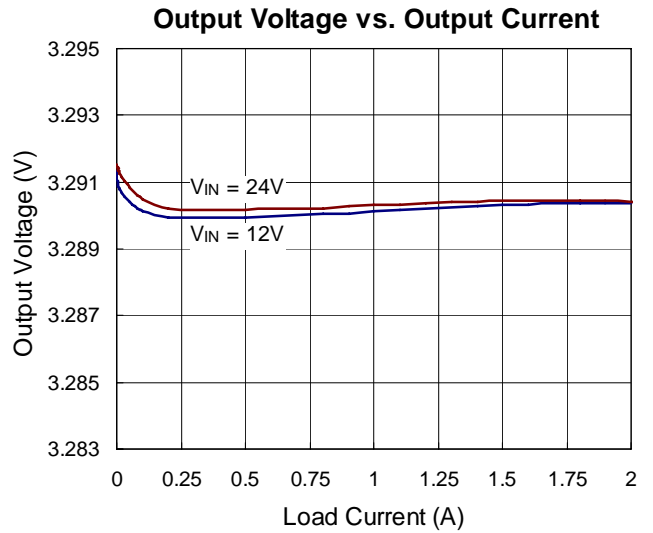
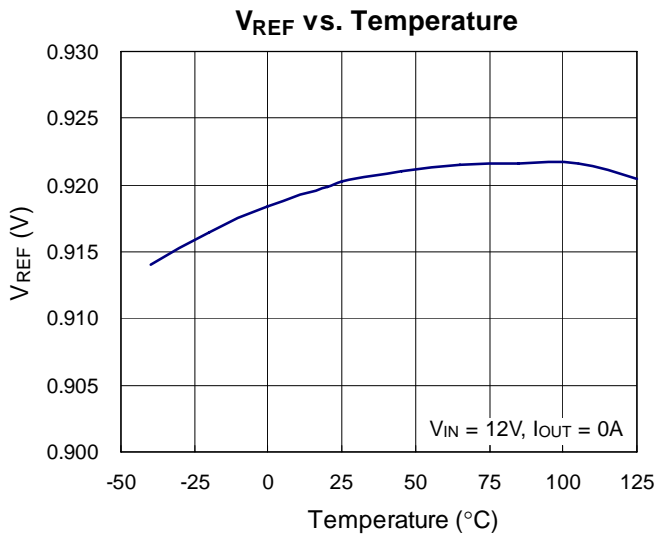
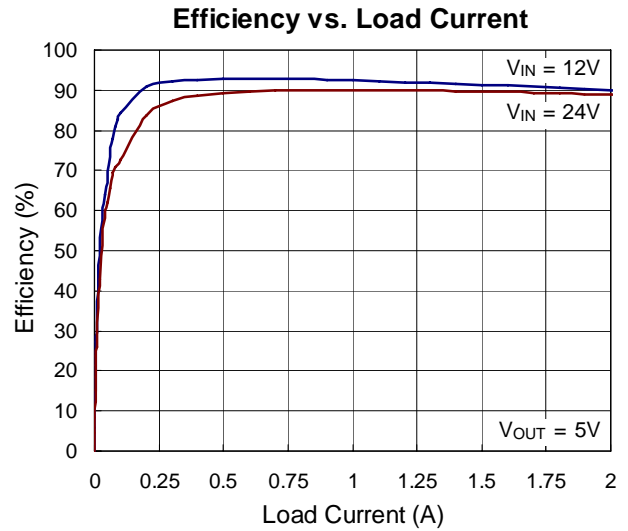
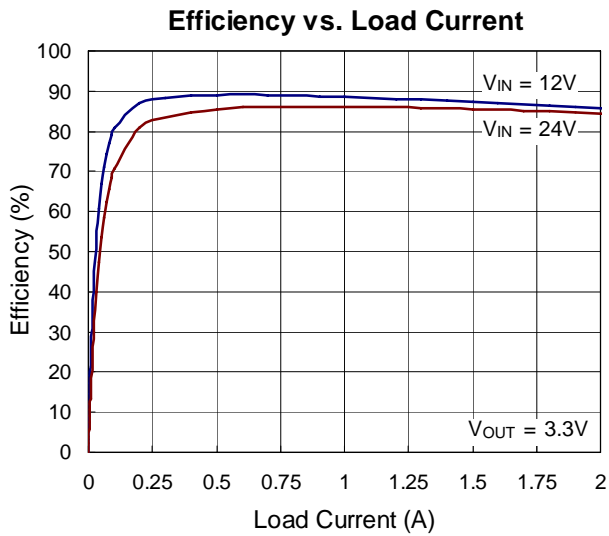

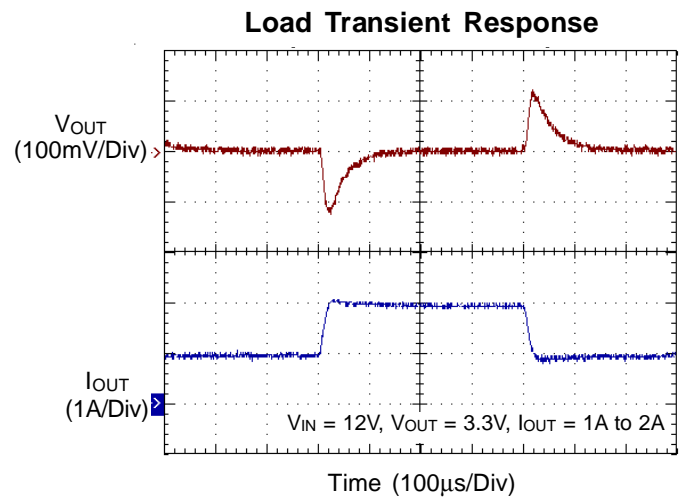
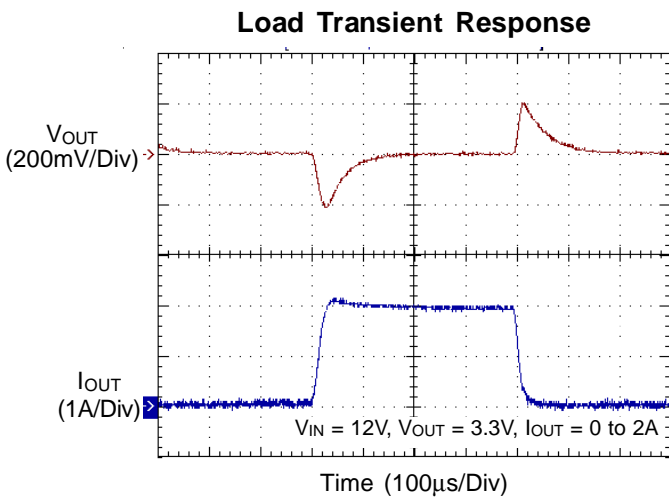
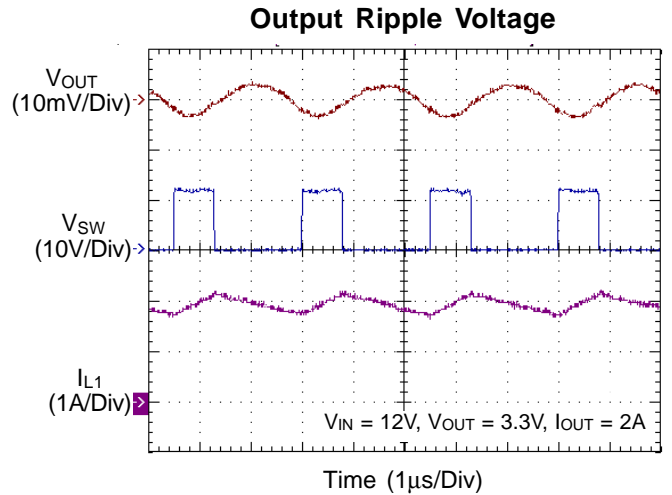
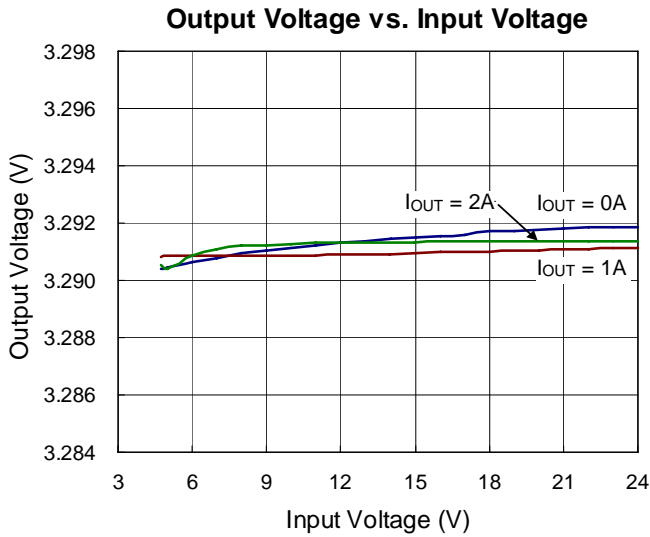
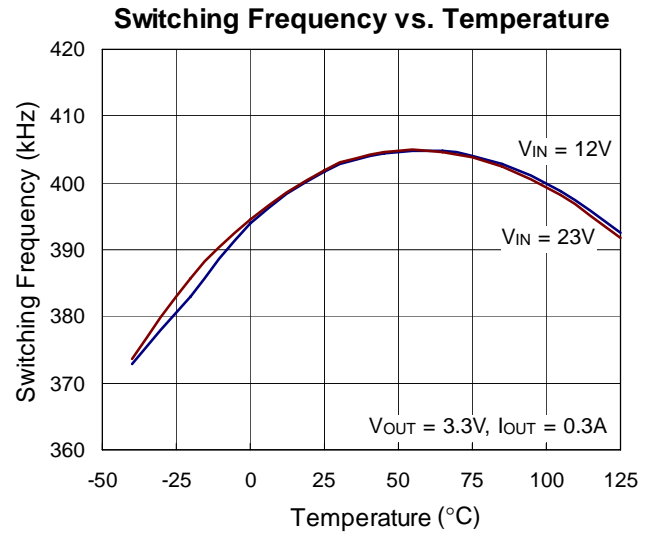
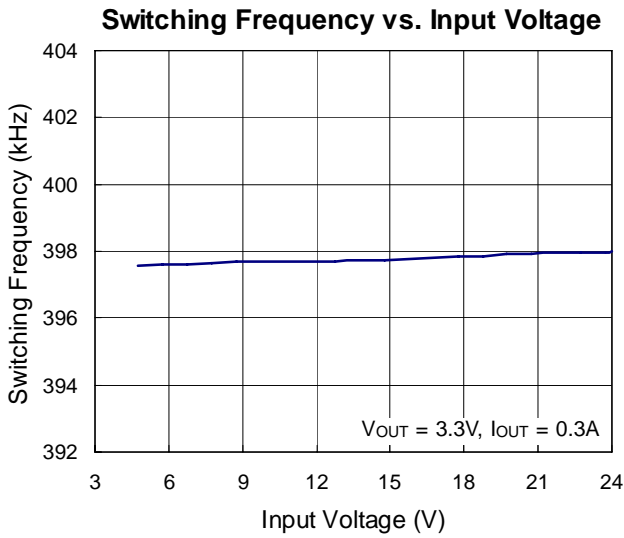

### Power On from EN

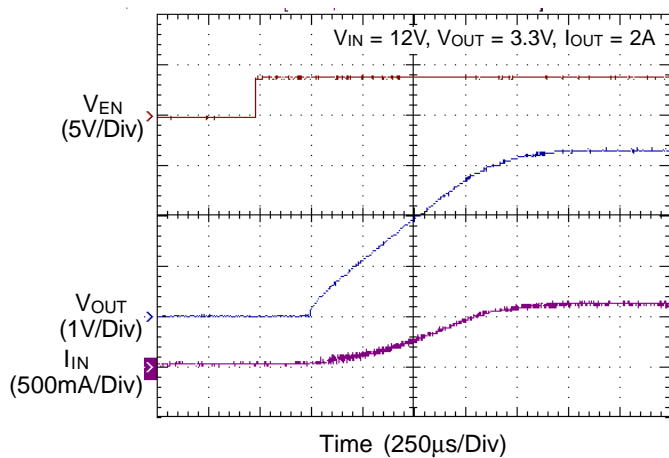

### Power Off from EN

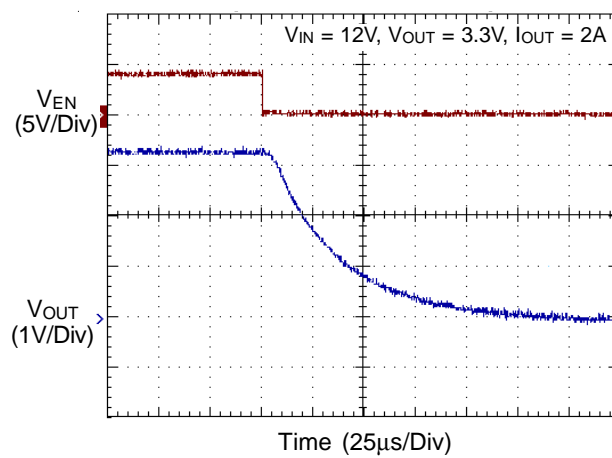



## Application Information

The RT8268 is an asynchronous high voltage buck converter that can support the input voltage range from 4.75V to 24V and the output current can be up to 2A.

### Output Voltage Setting

The resistive divider allows the FB pin to sense the output voltage as shown in Figure 1.

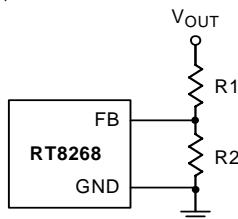

Figure 1. Output Voltage Setting

The output voltage is set by an external resistive divider according to the following equation :

$$V_{OUT} = V_{FB} \left( 1 + \frac{R1}{R2} \right)$$

Where  $V_{FB}$  is the feedback reference voltage (0.92V typ.).

### External Bootstrap Diode

Connect a 10nF low ESR ceramic capacitor between the BOOT pin and SW pin. This capacitor provides the gate driver voltage for the high side MOSFET.

It is recommended to add an external bootstrap diode between an external 5V and the BOOT pin for efficiency improvement when input voltage is lower than 5.5V or duty ratio is higher than 65%. The bootstrap diode can be a low cost one such as 1N4148 or BAT54.

The external 5V can be a 5V fixed input from system or a 5V output of the RT8268.

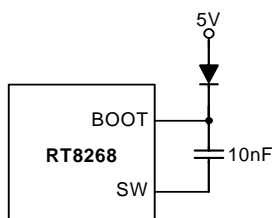

Figure 2. External Bootstrap Diode

### Soft-Start

The RT8268 contains an external soft-start clamp that gradually raises the output voltage. The soft-start timing can be programmed by the external capacitor between SS pin and GND. The chip provides a 10μA charge current for the external capacitor. If 10nF capacitor is used to set the soft-start and its period will be 1ms (typ.).

### Inductor Selection

The inductor value and operating frequency determine the ripple current according to a specific input and output voltage. The ripple current  $\Delta I_L$  increases with higher  $V_{IN}$  and decreases with higher inductance.

$$\Delta I_L = \left[ \frac{V_{OUT}}{f \times L} \right] \times \left[ 1 - \frac{V_{OUT}}{V_{IN}} \right]$$

Having a lower ripple current reduces not only the ESR losses in the output capacitors but also the output voltage ripple. High frequency with small ripple current can achieve highest efficiency operation. However, it requires a large inductor to achieve this goal.

For the ripple current selection, the value of  $\Delta I_L = 0.24(I_{MAX})$  will be a reasonable starting point. The largest ripple current occurs at the highest  $V_{IN}$ . To guarantee that the ripple current stays below the specified maximum, the inductor value should be chosen according to the following equation :

$$L = \left[ \frac{V_{OUT}}{f \times \Delta I_L(MAX)} \right] \times \left[ 1 - \frac{V_{OUT}}{V_{IN(MAX)}} \right]$$

### Inductor Core Selection

The inductor type must be selected once the value for L is known. Generally speaking, high efficiency converters can not afford the core loss found in low cost powdered iron cores. So, the more expensive ferrite or mollypermalloy cores will be a better choice.

The selected inductance rather than the core size for a fixed inductor value is the key for actual core loss. As the inductance increases, core losses decrease. Unfortunately, increase of the inductance requires more turns of wire and therefore the copper losses will increase.

Ferrite designs are preferred at high switching frequency due to the characteristics of very low core losses. So, design goals can focus on the reduction of copper loss and the saturation prevention.

Ferrite core material saturates “hard”, which means that inductance collapses abruptly when the peak design current is exceeded. The previous situation results in an abrupt increase in inductor ripple current and consequent output voltage ripple.

Do not allow the core to saturate!

Different core materials and shapes will change the size/current and price/current relationship of an inductor.

Toroid or shielded pot cores in ferrite or permalloy materials are small and do not radiate energy. However, they are usually more expensive than the similar powdered iron inductors. The rule for inductor choice mainly depends on the price vs. size requirement and any radiated field/EMI requirements.

### Diode Selection

When the power switch turns off, the path for the current is through the diode connected between the switch output and ground. This forward biased diode must have a minimum voltage drop and recovery times. Schottky diode is recommended and it should be able to handle those current. The reverse voltage rating of the diode should be greater than the maximum input voltage, and current rating should be greater than the maximum load current. For more detail please refer to Table 4.

### C<sub>IN</sub> and C<sub>OUT</sub> Selection

The input capacitance, C<sub>IN</sub>, is needed to filter the trapezoidal current at the source of the high side MOSFET. To prevent large ripple current, a low ESR input capacitor sized for the maximum RMS current should be used. The RMS current is given by :

$$I_{RMS} = I_{OUT(MAX)} \frac{V_{OUT}}{V_{IN}} \sqrt{\frac{V_{IN}}{V_{OUT}} - 1}$$

This formula has a maximum at  $V_{IN} = 2V_{OUT}$ , where  $I_{RMS} = I_{OUT}/2$ . This simple worst-case condition is commonly used for design because even significant deviations do not offer much relief.

Choose a capacitor rated at a higher temperature than required. Several capacitors may also be paralleled to meet size or height requirements in the design.

For the input capacitor, a 10μF low ESR ceramic capacitor is recommended. For the recommended capacitor, please

refer to table 3 for more detail.

The selection of C<sub>OUT</sub> is determined by the required ESR to minimize voltage ripple.

Moreover, the amount of bulk capacitance is also a key for C<sub>OUT</sub> selection to ensure that the control loop is stable. Loop stability can be checked by viewing the load transient response as described in a later section.

The output ripple, ΔV<sub>OUT</sub>, is determined by :

$$\Delta V_{OUT} \leq \Delta I_L \left[ ESR + \frac{1}{8fC_{OUT}} \right]$$

The output ripple will be highest at the maximum input voltage since ΔI<sub>L</sub> increases with input voltage. Multiple capacitors placed in parallel may be needed to meet the ESR and RMS current handling requirement. Dry tantalum, special polymer, aluminum electrolytic and ceramic capacitors are all available in surface mount packages. Special polymer capacitors offer very low ESR value. However, it provides lower capacitance density than other types. Although Tantalum capacitors have the highest capacitance density, it is important to only use types that pass the surge test for use in switching power supplies. Aluminum electrolytic capacitors have significantly higher ESR. However, it can be used in cost-sensitive applications for ripple current rating and long term reliability considerations. Ceramic capacitors have excellent low ESR characteristics but can have a high voltage coefficient and audible piezoelectric effects. The high Q of ceramic capacitors with trace inductance can also lead to significant ringing.

Higher values, lower cost ceramic capacitors are now becoming available in smaller case sizes. Their high ripple current, high voltage rating and low ESR make them ideal for switching regulator applications. However, care must be taken when these capacitors are used at input and output. When a ceramic capacitor is used at the input and the power is supplied by a wall adapter through long wires, a load step at the output can induce ringing at the input, V<sub>IN</sub>. At best, this ringing can couple to the output and be mistaken as loop instability. At worst, a sudden inrush of current through the long wires can potentially cause a voltage spike at V<sub>IN</sub> large enough to damage the part.

**Checking Transient Response**

The regulator loop response can be checked by looking at the load transient response. Switching regulators take several cycles to respond to a step in load current. When a load step occurs,  $V_{OUT}$  immediately shifts by an amount equal to  $\Delta I_{LOAD} (ESR)$  also begins to charge or discharge  $C_{OUT}$  generating a feedback error signal for the regulator to return  $V_{OUT}$  to its steady-state value. During this recovery time,  $V_{OUT}$  can be monitored for overshoot or ringing that would indicate a stability problem.

**Thermal Considerations**

The maximum power dissipation depends on the thermal resistance of IC package, PCB layout, the rate of surroundings airflow and temperature difference between junction to ambient. The maximum power dissipation can be calculated by following formula :

$$P_{D(MAX)} = (T_{J(MAX)} - T_A) / \theta_{JA}$$

Where  $T_{J(MAX)}$  is the maximum operation junction temperature,  $T_A$  is the ambient temperature and the  $\theta_{JA}$  is the junction to ambient thermal resistance.

For recommended operating conditions specification of RT8268, the maximum junction temperature is 125°C. The junction to ambient thermal resistance  $\theta_{JA}$  for MSOP-10 (Exposed Pad) package is 86°C/W and for SOP-8 is 120°C/W on the standard JEDEC 51-7 four-layers thermal test board. The maximum power dissipation at  $T_A = 25^\circ\text{C}$  can be calculated by following formula :

$$P_{D(MAX)} = (125^\circ\text{C} - 25^\circ\text{C}) / (86^\circ\text{C/W}) = 1.163\text{W for MSOP-10 (Exposed Pad)}$$

$$P_{D(MAX)} = (125^\circ\text{C} - 25^\circ\text{C}) / (120^\circ\text{C/W}) = 0.833\text{W for SOP-8}$$

The maximum power dissipation depends on operating ambient temperature for fixed  $T_{J(MAX)}$  and thermal resistance  $\theta_{JA}$ . For RT8268 packages, the Figure 3 of derating curves allows the designer to see the effect of rising ambient temperature on the maximum power dissipation allowed.

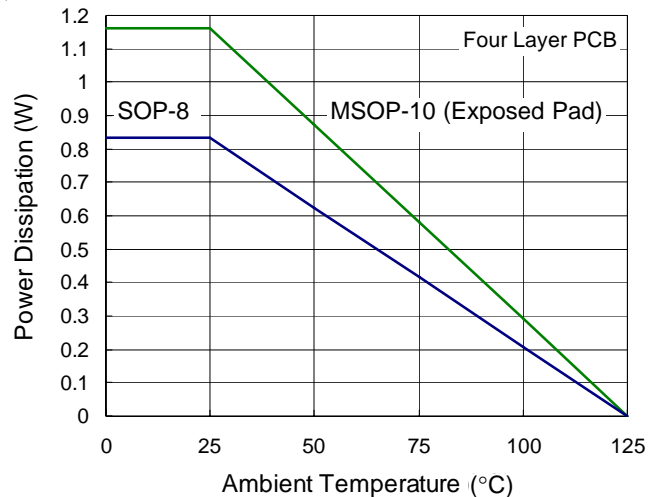

Figure 3. Derating Curves for RT8268 Packages

**Layout Consideration**

Follow the PCB layout guidelines for optimal performance of the RT8268.

- ▶ Keep the traces of the main current paths as short and wide as possible.
- ▶ Put the input capacitor as close as possible to the device pins (VIN and GND).
- ▶ LX node is with high frequency voltage swing and should be kept at small area. Keep sensitive components away from the LX node to prevent stray capacitive noise pick-up.
- ▶ Place the feedback components to the FB pin as close as possible.
- ▶ The GND and Exposed Pad should be connected to a strong ground plane for heat sinking and noise protection.

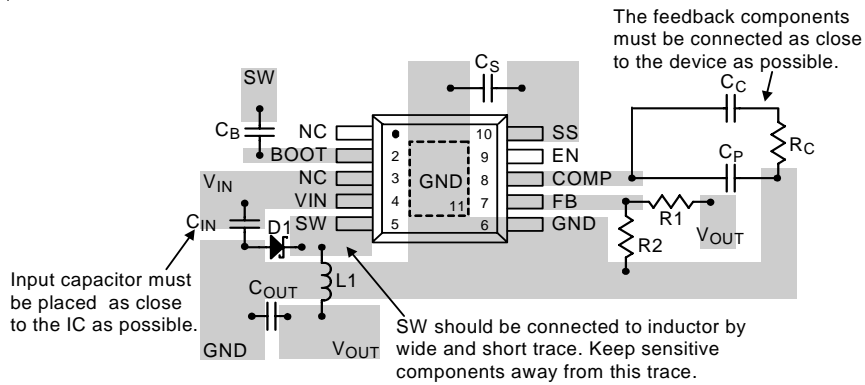

Figure 4. PCB Layout Guide for MSOP-10 (Exposed Pad)

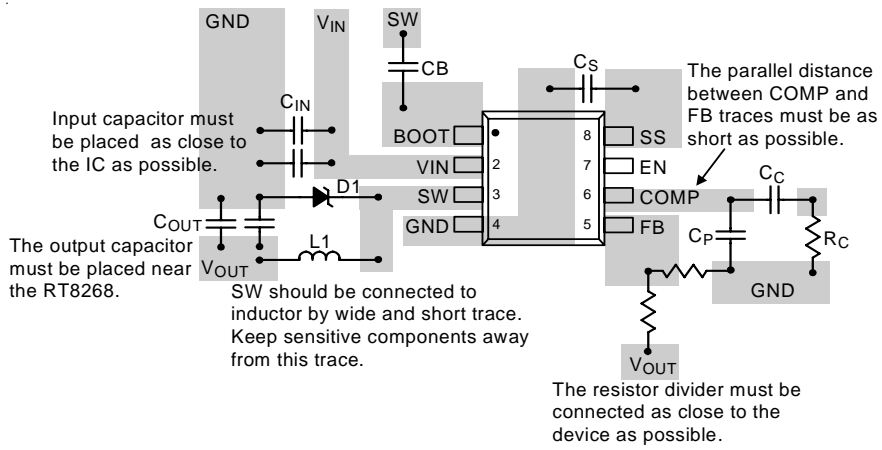

Figure 5. PCB Layout Guide for SOP-8

**Table 2. Suggested Inductors for Typical Application Circuit**

Component Supplier	Series	Dimensions (mm)
<b>TDK</b>	SLF12555T	12.5 x 12.5 x 5.5
<b>TAIYO YUDEN</b>	NR8040	8 x 8 x 4
<b>TDK</b>	SLF12565T	12.5 x 12.5 x 6.5

**Table 3. Suggested Capacitors for C<sub>IN</sub> and C<sub>OUT</sub>**

Location	Component Supplier	Part No.	Capacitance (μF)	Case Size
<b>C<sub>IN</sub></b>	<b>MURATA</b>	GRM31CR61E106K	10	1206
<b>C<sub>IN</sub></b>	<b>TDK</b>	C3225X5R1E106K	10	1206
<b>C<sub>IN</sub></b>	<b>TAIYO YUDEN</b>	TMK316BJ106ML	10	1206
<b>C<sub>OUT</sub></b>	<b>MURATA</b>	GRM32ER61E226M	22	1210
<b>C<sub>OUT</sub></b>	<b>TDK</b>	C3225X5R0J226M	22	1210
<b>C<sub>OUT</sub></b>	<b>TAIYO YUDEN</b>	EMK325BJ226MM	22	1210

**Table 4. Suggested Diode**

Component Supplier	Series	V <sub>RRM</sub> (V)	I <sub>OUT</sub> (A)	Package
<b>DIODES</b>	B330A	30	3	SMA
<b>DIODES</b>	B220A	20	2	SMA
<b>PANJIT</b>	SK22	20	2	DO-214AA
<b>PANJIT</b>	SK23	30	2	DO-214AA

Outline Dimension

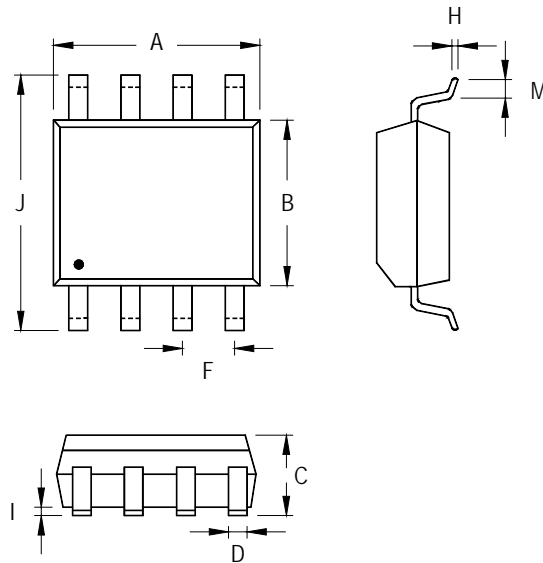

Symbol	Dimensions In Millimeters		Dimensions In Inches	
	Min	Max	Min	Max
A	4.801	5.004	0.189	0.197
B	3.810	3.988	0.150	0.157
C	1.346	1.753	0.053	0.069
D	0.330	0.508	0.013	0.020
F	1.194	1.346	0.047	0.053
H	0.170	0.254	0.007	0.010
I	0.050	0.254	0.002	0.010
J	5.791	6.200	0.228	0.244
M	0.400	1.270	0.016	0.050

8-Lead SOP Plastic Package

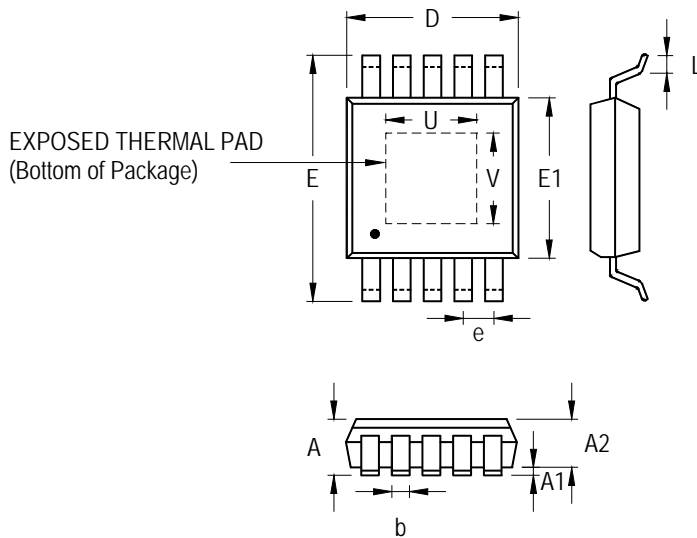

Symbol	Dimensions In Millimeters		Dimensions In Inches	
	Min	Max	Min	Max
A	0.810	1.100	0.032	0.043
A1	0.000	0.100	0.000	0.004
A2	0.750	0.950	0.030	0.037
b	0.170	0.270	0.007	0.011
D	2.900	3.100	0.114	0.122
e	0.500		0.020	
E	4.800	5.000	0.189	0.197
E1	2.900	3.100	0.114	0.122
L	0.400	0.800	0.016	0.031
U	1.300	1.700	0.051	0.067
V	1.500	1.900	0.059	0.075

**10-Lead MSOP (Exposed Pad) Plastic Package**

**Richtek Technology Corporation**

Headquarter  
 5F, No. 20, Taiyuen Street, Chupei City  
 Hsinchu, Taiwan, R.O.C.  
 Tel: (8863)5526789 Fax: (8863)5526611

**Richtek Technology Corporation**

Taipei Office (Marketing)  
 5F, No. 95, Minchiuan Road, Hsintien City  
 Taipei County, Taiwan, R.O.C.  
 Tel: (8862)86672399 Fax: (8862)86672377  
 Email: marketing@richtek.com

Information that is provided by Richtek Technology Corporation is believed to be accurate and reliable. Richtek reserves the right to make any change in circuit design, specification or other related things if necessary without notice at any time. No third party intellectual property infringement of the applications should be guaranteed by users when integrating Richtek products into any application. No legal responsibility for any said applications is assumed by Richtek.

单击下面可查看定价，库存，交付和生命周期等信息

[>>Richtek\(台湾立锜\)](#)