

1.5MHz, 600mA, High Efficiency PWM Step-Down Converter

General Description

The RT8099/A is a Pulse-Width-Modulated (PWM) DC/DC step-down converter, and is capable of delivering 0.6A output current over a wide input voltage range from 2.7V to 5.5V. The RT8099/A is ideally suited for portable electronic devices that are powered from 1-cell Li-ion battery such as cellular phones, PDAs and handy-terminals. Internal synchronous rectifier with low $R_{DS(ON)}$ dramatically reduces conduction loss at PWM mode. No external schottky barrier diode is required in practical application.

The RT8099/A enters low-dropout mode when normal PWM cannot provide regulated output voltage by continuously turning on the high-side P-MOSFET. The RT8099/A enters shut-down mode and consumes less than 0.1 μ A when the EN pin is pulled low. The switching ripple is easily smoothed-out by small package filtering elements due to 1.5MHz high switching frequency. Other features include soft-start, auto discharge, lower internal reference voltage, over-temperature protection, and over-current protection.

The RT8099/A is available in the small UDFN-6L 1.6x1.6 package for saving PCB space.

Features

- 2.7V to 5.5V Input Range
- Adjustable Output from 0.7V to 5V
- 0.6A Output Current
- 95% Efficiency
- No Schottky Barrier Diode Required
- 1.5MHz Spread Spectrum/Fixed Frequency PWM Operation
- Auto Discharge Function
- Over-Current Protection
- Over-Temperature Protection
- Integrated Soft-Start Function
- Small 6-Lead UDFN Package
- RoHS Compliant and Halogen Free

Applications

- Cellular Telephones
- Personal Information Appliances
- Wireless and DSL Modems
- MP3 Players
- Portable Instruments

Marking Information

RT8099GQU

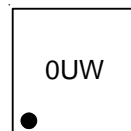

0U : Product Code

W : Date Code

Simplified Application Circuit

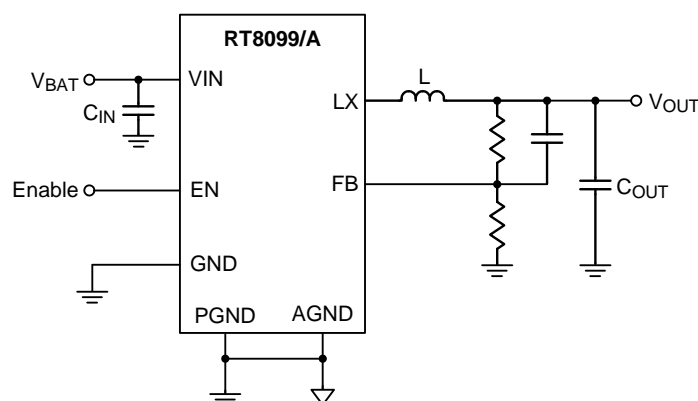

Ordering Information

RT8099/A □ □

- Package Type
QU : UDFN-6L 1.6x1.6 (U-Type)
- Lead Plating System
G : Green (Halogen Free and Pb Free)
- RT8099 : Spread Spectrum
RT8099A : Fixed Frequency

Pin Configurations

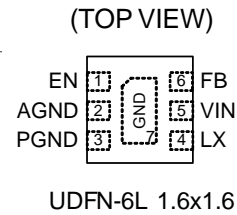

Note :

Richtek products are :

- ▶ RoHS compliant and compatible with the current requirements of IPC/JEDEC J-STD-020.
- ▶ Suitable for use in SnPb or Pb-free soldering processes.

Functional Pin Description

Pin No.	Pin Name	Pin Function
1	EN	Enable Control Input (Active High).
2	AGND	Analog Ground.
3	PGND	Power Ground.
4	LX	Switch Node.
5	VIN	Power Input.
6	FB	Feedback Voltage Input.
7 (Exposed Pad)	GND	Ground. The exposed pad must be soldered to a large PCB and connected to GND for maximum power dissipation.

Function Block Diagram

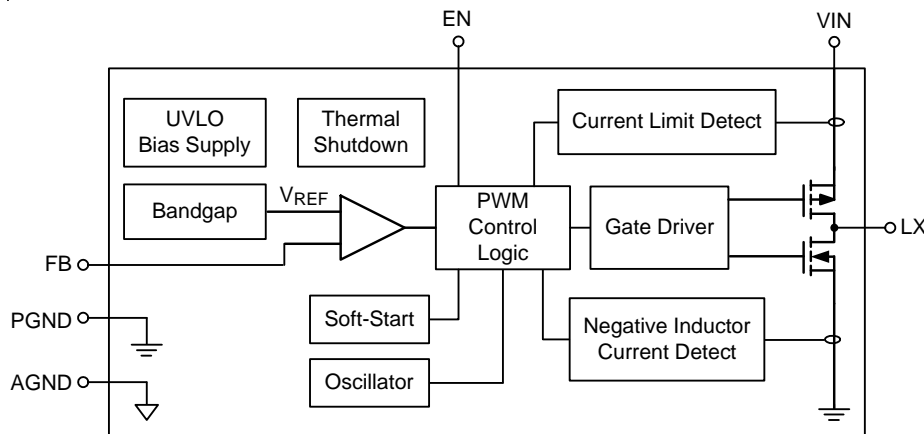

Operation

The RT8099/A is a synchronous DC/DC step-down converter that can support the input voltage range from 2.7V to 5.5V. The output current is up to 600mA. While the power plugs in and EN = H, V_{OUT} is soft-started to avoid the inrush current of V_{IN} by the soft-start block. Normally, the high-side MOSFET is turned on by the PWM control logic block which drives the gate driver block when V_{FB} is lower than the internal reference voltage. After V_{FB} is higher than the internal reference voltage, the high-side MOSFET will be turned off. While the high-side MOSFET is turned off, the low-side MOSFET is turned on until the current of the inductor is around zero by the negative inductor current detection block. When the current of high-

side MOSFET is over the rating current, the high-side MOSFET is turned off. When the temperature is over the rating temperature, the high-side MOSFET is turned off until the temperature is dropped by the thermal shutdown block. After the thermal shutdown is released, V_{OUT} will be soft-started again. When V_{IN} is lower than 2.1V, the high-side MOSFET is turned off by the UVLO block. After V_{IN} is higher than 2.2V, V_{OUT} will be soft-started again. The reference voltage is provided by the bandgap block. The internal clock related to the switching frequency is provided by the oscillator block.

Absolute Maximum Ratings (Note 1)

- Supply Input Voltage, V_{IN} ----- 6V
- EN, FB Pin Voltage ----- $-0.3V$ to V_{IN}
- Power Dissipation, P_D @ $T_A = 25^\circ C$
 UDFN-6L 1.6x1.6 ----- 2.15W
- Package Thermal Resistance (Note 2)
 UDFN-6L 1.6x1.6, θ_{JA} ----- $46.5^\circ C/W$
- Lead Temperature (Soldering, 10 sec.) ----- $260^\circ C$
- Junction Temperature ----- $150^\circ C$
- Storage Temperature Range ----- $-65^\circ C$ to $150^\circ C$
- ESD Susceptibility (Note 3)
 HBM (Human Body Model) ----- 2kV
 MM (Machine Model) ----- 200V

Recommended Operating Conditions (Note 4)

- Supply Input Voltage, V_{IN} ----- 2.3V to 5.5V
- Junction Temperature ----- $-40^\circ C$ to $125^\circ C$
- Ambient Temperature Range ----- $-40^\circ C$ to $85^\circ C$

Electrical Characteristics

($V_{IN} = 3.6V$, $V_{OUT} = 1.8V$, $V_{REF} = 0.6V$, $L = 2.2\mu H$, $C_{IN} = 4.7\mu F$, $C_{OUT} = 10\mu F$, $I_{MAX} = 0.6A$, $T_A = 25^\circ C$, unless otherwise specified)

Parameter	Symbol	Test Conditions	Min	Typ	Max	Unit	
Input Voltage Start-Up	V_{IN}		2.3	--	5.5	V	
Input Voltage Range	V_{IN}	$I_{OUT} = 600mA$	2.7	--	5.5	V	
Quiescent Current for Adjustable Output Voltage	I_{Q_adj}	$I_{OUT} = 0mA$, $V_{FB} = V_{REF} + 10\%$, without include EN pin current (Note 5)	--	20	35	μA	
Shutdown Current	I_{SHDN}	EN = GND	--	0.1	1	μA	
Reference Voltage	V_{REF}	For Adjustable Output Voltage	0.591	0.6	0.609	V	
Adjustable Output Range	V_{OUT}		0.7	--	V_{IN}	V	
Output Voltage Accuracy	ΔV_{OUT}	$V_{IN} = 2.7V$ to $5.5V$, $0A < I_{OUT} < 0.6A$	-3	--	3	%	
FB Input Current	I_{FB}	$V_{FB} = V_{IN}$	-50	--	50	nA	
High-Side MOSFET On-Resistance	$R_{DS(ON)_P}$	$I_{OUT} = 200mA$	$V_{IN} = 3.6V$	--	0.28	--	Ω
			$V_{IN} = 2.5V$	--	0.38	--	
Low-Side MOSFET On-Resistance	$R_{DS(ON)_N}$	$I_{OUT} = 200mA$	$V_{IN} = 3.6V$	--	0.25	--	Ω
			$V_{IN} = 2.5V$	--	0.35	--	
High-Side MOSFET Current Limit	I_{LIM_P}		1	1.5	2	A	
EN Input Voltage	Logic-High	V_{EN_H}	1.5	--	--	V	
	Logic-Low	V_{EN_L}	--	--	0.4		
Under Voltage Lock Out Threshold (Rising)	UVLO_R	V_{IN} Rising	2.1	2.2	2.3	V	
UVLO Hysteresis	UVLO_Hys	V_{IN} Falling	--	0.1	--	V	

Parameter	Symbol	Test Conditions	Min	Typ	Max	Unit
Oscillator Frequency	f_{OSC}	$V_{IN} = 3.6V, I_{OUT} = 600mA$	--	1.5	--	MHz
Thermal Shutdown Temperature	T_{SD}		--	150	--	°C
Maximum Duty Cycle			100	--	--	%
Soft-Start Time	t_{SS}		--	150	--	μs
Discharge Time	t_{DIS}	$C_{OUT} = 10\mu F$	--	5	10	ms
EN Pull-Low Resistor	R_{EN}		--	300	--	kΩ

Note 1. Stresses beyond those listed “Absolute Maximum Ratings” may cause permanent damage to the device. These are stress ratings only, and functional operation of the device at these or any other conditions beyond those indicated in the operational sections of the specifications is not implied. Exposure to absolute maximum rating conditions may affect device reliability.

Note 2. θ_{JA} is measured at $T_A = 25^\circ C$ on a high effective thermal conductivity four-layer test board per JEDEC 51-7.

Note 3. Devices are ESD sensitive. Handling precaution is recommended.

Note 4. The device is not guaranteed to function outside its operating conditions.

Note 5. Supply 660mV in FB pin and record the VIN pin current.

Typical Application Circuit

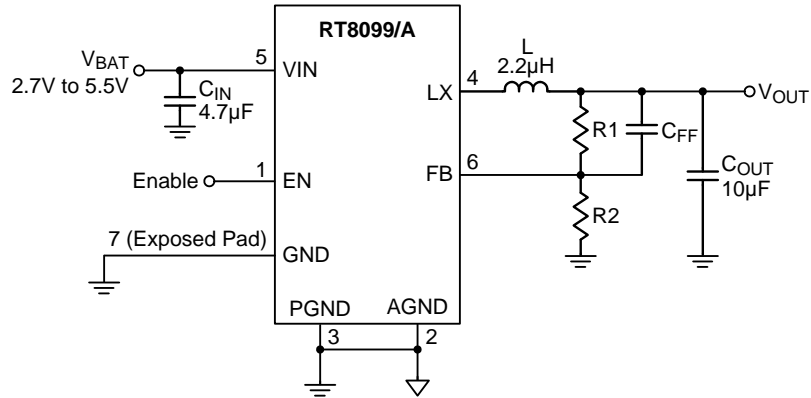

$$V_{OUT} = V_{REF} \times \left(1 + \frac{R1}{R2}\right)$$

with $R2 = 60k\Omega$ to $300k\Omega$ so the $I_{R2} = 10\mu A$ to $2\mu A$, and $(R1 \times C_{FF})$ should be in the range between 22.4×10^{-6} and 88×10^{-6} for component selection.

Figure 1. Adjustable Voltage Regulator

Typical Operating Characteristics

Efficiency vs. Output Current

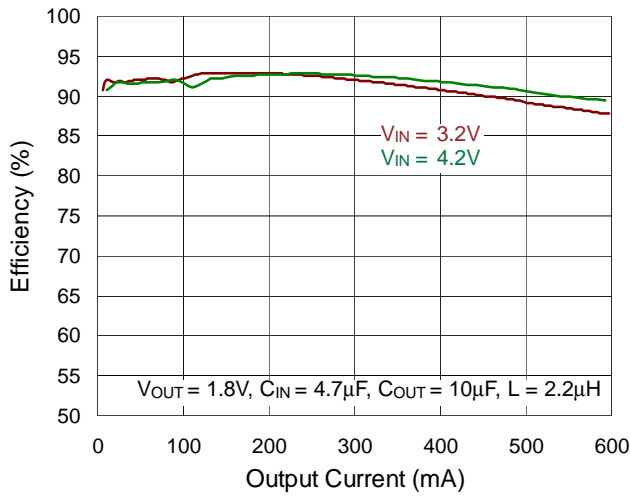

Switching Frequency vs. Input Voltage

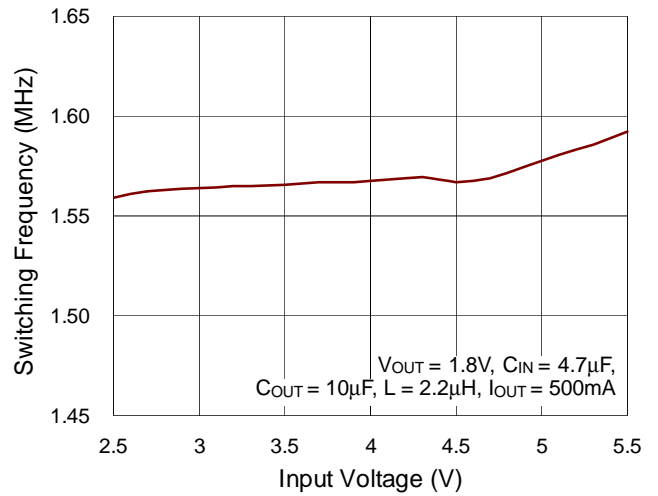

Quiescent Current vs. Input Voltage

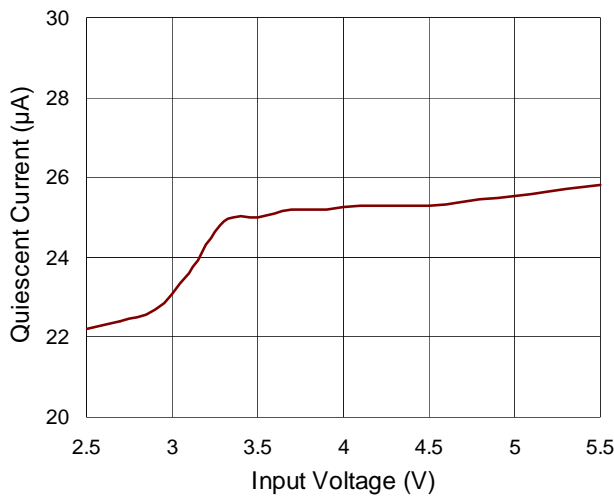

Quiescent Current vs. Temperature

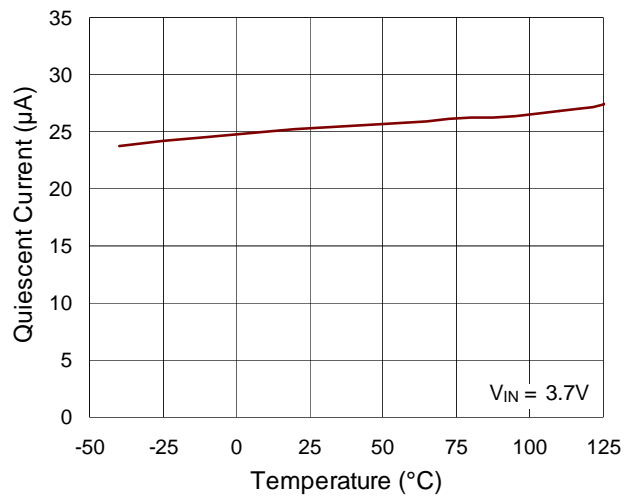

Reference Voltage vs. Input Voltage

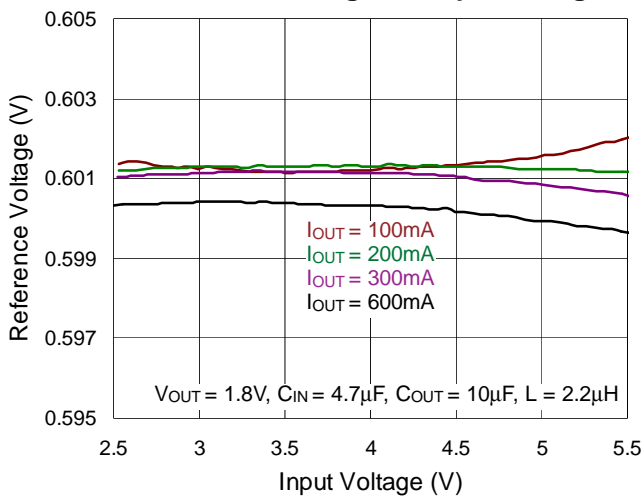

Reference Voltage vs. Temperature

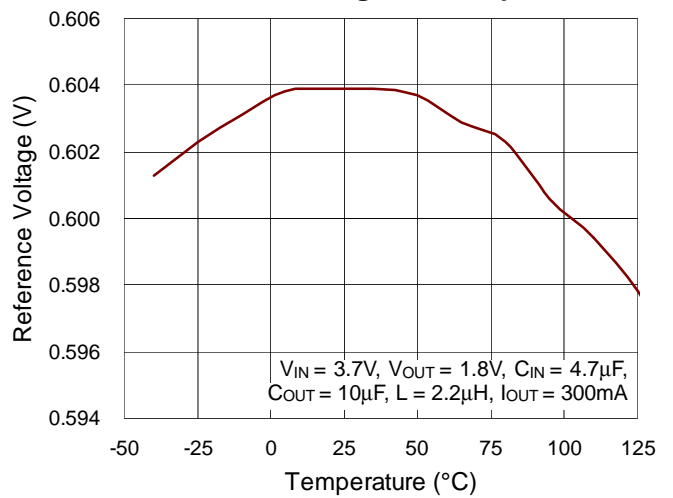

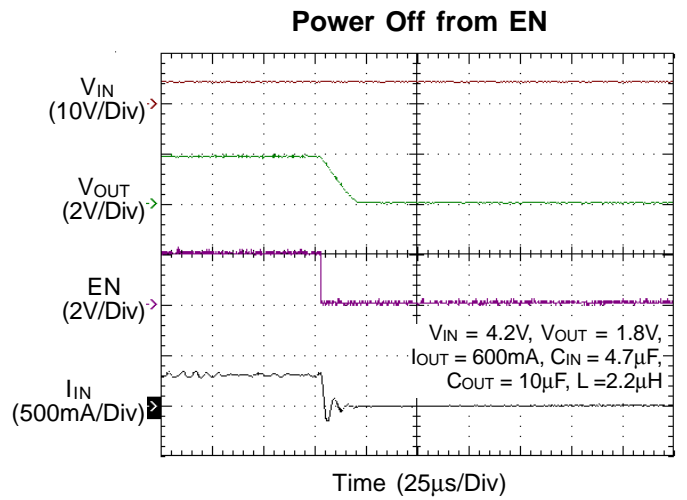
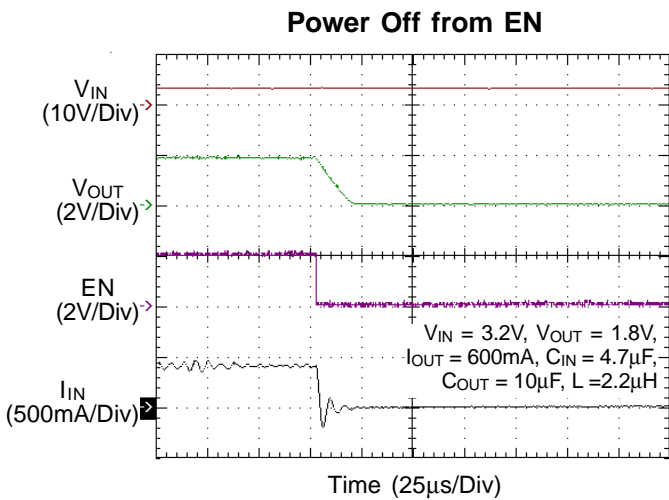
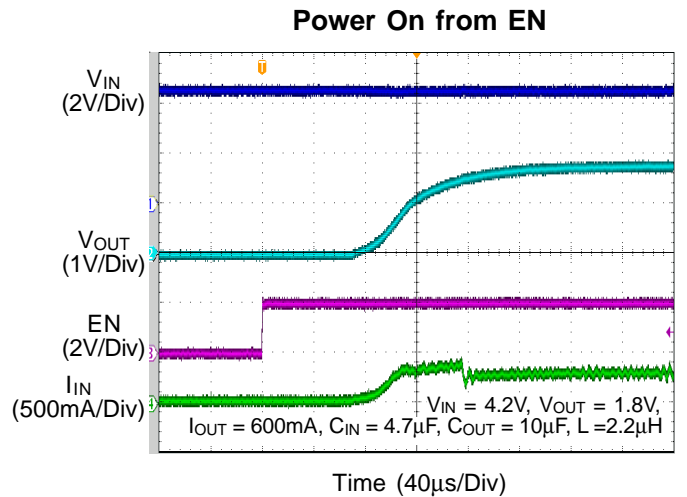
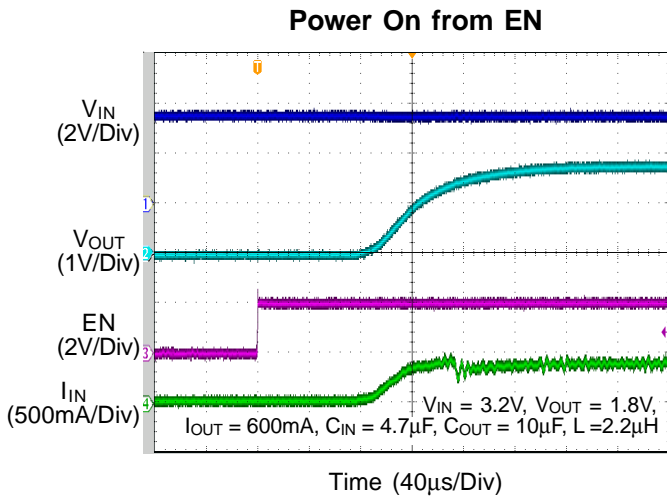
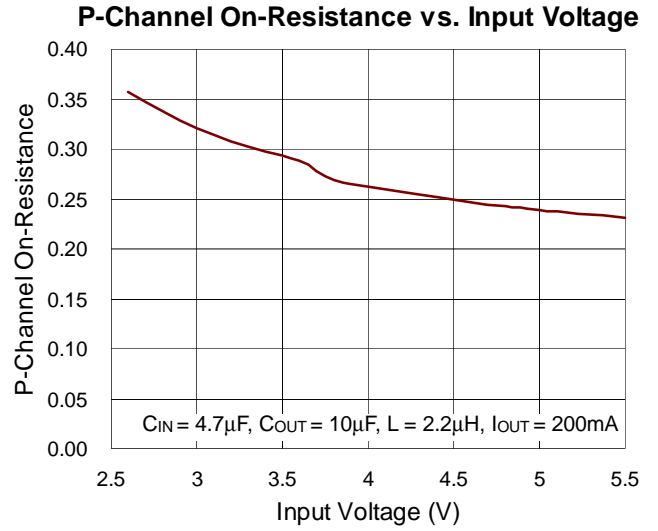
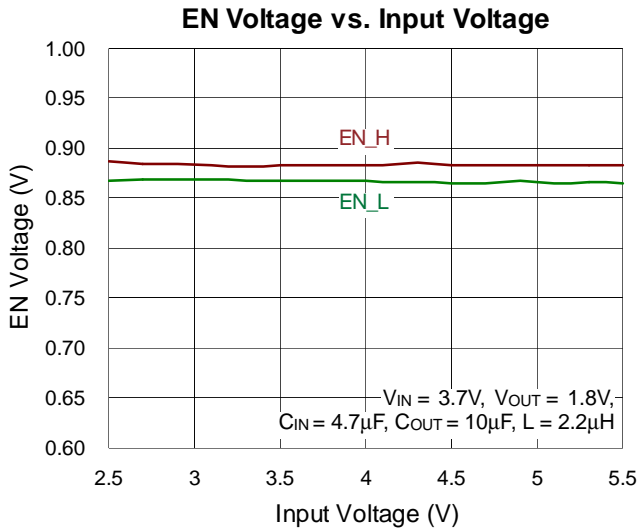

Applications Information

The basic RT8099/A application circuit is shown in Typical Application Circuit. External component selection is determined by the maximum load current and begins with the selection of the inductor value and operating frequency followed by C_{IN} and C_{OUT} .

Inductor Selection

For a given input and output voltage, the inductor value and operating frequency determine the ripple current. The ripple current ΔI_L increases with higher V_{IN} and decreases with higher inductance.

$$\Delta I_L = \left(\frac{V_{OUT}}{f \times L} \right) \times \left(1 - \frac{V_{OUT}}{V_{IN}} \right)$$

Having a lower ripple current reduces the ESR losses in the output capacitors and the output voltage ripple. Highest efficiency operation is achieved at low frequency with small ripple current. This, however, requires a large inductor.

A reasonable starting point for selecting the ripple current is $\Delta I_L = 0.4 (I_{MAX})$. The largest ripple current occurs at the highest V_{IN} . To guarantee that the ripple current stays below a specified maximum, the inductor value should be chosen according to the following equation :

$$L = \left(\frac{V_{OUT}}{f \times \Delta I_L(MAX)} \right) \times \left(1 - \frac{V_{OUT}}{V_{IN(MAX)}} \right)$$

A 2.2 μ H inductor is recommended for L.

Table 1. Suggested Inductors and Suppliers

Model	Vendor	Dimensions L x W x H (mm)
NR4018T2R2M	Taiyo	4.0 x 4.0 x 1.8
VLS3010ET-2R2M	TDK	3.0 x 3.0 x 1.0
NR3010T2R2M	Taiyo	3.0 x 3.0 x 1.0
SWPA3010S2R2NT	Sunlord	3.0 x 3.0 x 1.0

C_{IN} and C_{OUT} Selection

The input capacitance, C_{IN} , is needed to filter the trapezoidal current at the Source of the high-side MOSFET. To prevent large ripple voltage, a low ESR input capacitor sized for the maximum RMS current should be used. RMS current is given by :

$$I_{RMS} = I_{OUT(MAX)} \frac{V_{OUT}}{V_{IN}} \sqrt{\frac{V_{IN}}{V_{OUT}} - 1}$$

This formula has a maximum at $V_{IN} = 2V_{OUT}$, where $I_{RMS} = I_{OUT} / 2$. This simple worst-case condition is commonly used for design because even significant deviations do not offer much relief. Note that ripple current ratings from capacitor manufacturers are often based on only 2000 hours of life which makes it advisable to further derate the capacitor, or choose a capacitor rated at a higher temperature than required. Several capacitors may also be paralleled to meet size or height requirements in the design.

The selection of C_{OUT} is determined by the Effective Series Resistance (ESR) that is required to minimize voltage ripple and load step transients, as well as the amount of bulk capacitance that is necessary to ensure that the control loop is stable. Loop stability can be checked by viewing the load transient response as described in a later section. The output ripple, ΔV_{OUT} , is determined by :

$$\Delta V_{OUT} \leq \Delta I_L \left(ESR + \frac{1}{8fC_{OUT}} \right)$$

The output ripple is highest at maximum input voltage since ΔI_L increases with input voltage. Multiple capacitors placed in parallel may be needed to meet the ESR and RMS current handling requirements. Dry tantalum, special polymer, aluminum electrolytic and ceramic capacitors are all available in surface mount packages. Special polymer capacitors offer very low ESR but have lower capacitance density than other types. Tantalum capacitors have the highest capacitance density but it is important to only use types that have been surge tested for use in switching power supplies. Aluminum electrolytic capacitors have significantly higher ESR but can be used in cost-sensitive applications that consideration is given to ripple current ratings and long term reliability. Ceramic capacitors have excellent low ESR characteristics but have a high voltage coefficient and audible piezoelectric effects. The high Q of ceramic capacitors with trace inductance can also lead to significant ringing.

Using Ceramic Input and Output Capacitors

Higher values, lower cost ceramic capacitors are now becoming available in smaller case sizes. Their high ripple current, high voltage rating and low ESR make them ideal

for switching regulator applications. However, care must be taken when these capacitors are used at the input and output. When a ceramic capacitor is used at the input and the power is supplied by a wall adapter through long wires, a load step at the output can induce ringing at the input, VIN. At best, this ringing can couple to the output and be mistaken as loop instability. At worst, a sudden inrush of current through the long wires can potentially cause a voltage spike at VIN large enough to damage the part.

Output Voltage Programming

The resistive divider allows the FB pin to sense a fraction of the output voltage as shown in Figure 2.

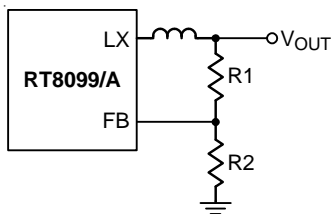

Figure 2. Setting the Output Voltage

For adjustable voltage mode, the output voltage is set by an external resistive divider according to the following equation :

$$V_{OUT} = V_{REF} \left(1 + \frac{R1}{R2} \right)$$

where V_{REF} is the internal reference voltage (0.6V typ.)

Thermal Considerations

For continuous operation, do not exceed absolute maximum junction temperature. The maximum power dissipation depends on the thermal resistance of the IC package, PCB layout, rate of surrounding airflow, and difference between junction and ambient temperature. The maximum power dissipation can be calculated by the following formula :

$$P_{D(MAX)} = (T_{J(MAX)} - T_A) / \theta_{JA}$$

where T_{J(MAX)} is the maximum junction temperature, T_A is the ambient temperature, and θ_{JA} is the junction to ambient thermal resistance.

For recommended operating condition specifications, the maximum junction temperature is 125°C. The junction to ambient thermal resistance, θ_{JA}, is layout dependent. For UDFN-6L 1.6x1.6 package, the thermal resistance, θ_{JA}, is 46.5°C/W on a standard JEDEC 51-7 four-layer thermal test board. The maximum power dissipation at T_A = 25°C can be calculated by the following formula :

$$P_{D(MAX)} = (125^\circ\text{C} - 25^\circ\text{C}) / (46.5^\circ\text{C/W}) = 2.15\text{W for UDFN-6L 1.6x1.6 package}$$

The maximum power dissipation depends on the operating ambient temperature for fixed T_{J(MAX)} and thermal resistance, θ_{JA}. The derating curve in Figure 3 allows the designer to see the effect of rising ambient temperature on the maximum power dissipation.

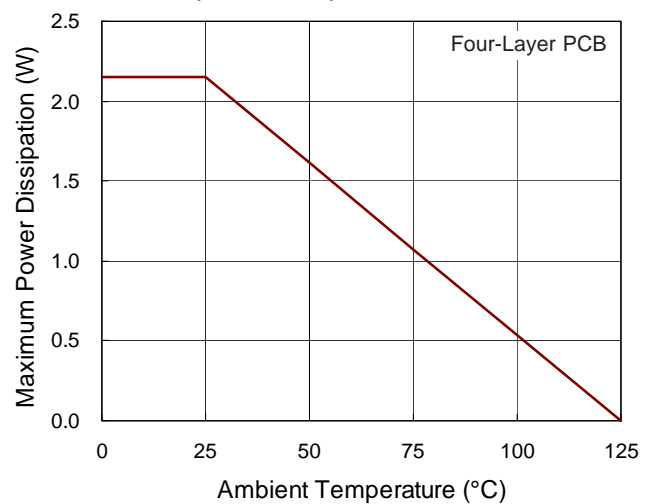

Figure 3. Derating Curve of Maximum Power Dissipation

Layout Considerations

Follow the PCB layout guidelines for optimal performance of RT8099/A.

- ▶ Put the input capacitor as close as possible to the device pins (VIN and GND).
- ▶ LX node is with high frequency voltage swing and should be kept small area. Keep analog components away from LX node to prevent stray capacitive noise pick-up.
- ▶ Connect feedback network behind the output capacitors. Keep the loop area small. Place the feedback components near the RT8099/A.
- ▶ Connect all analog grounds to a common node and then connect the common node to the power ground behind the output capacitors.

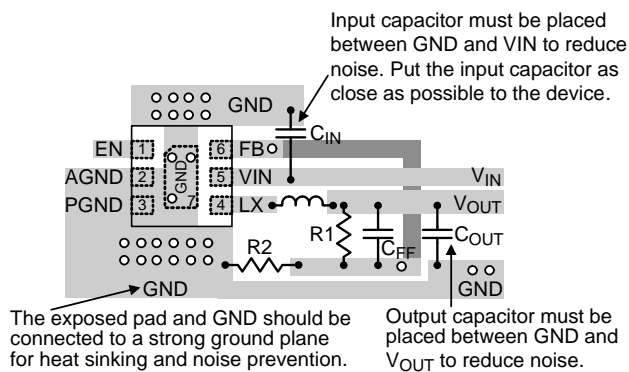
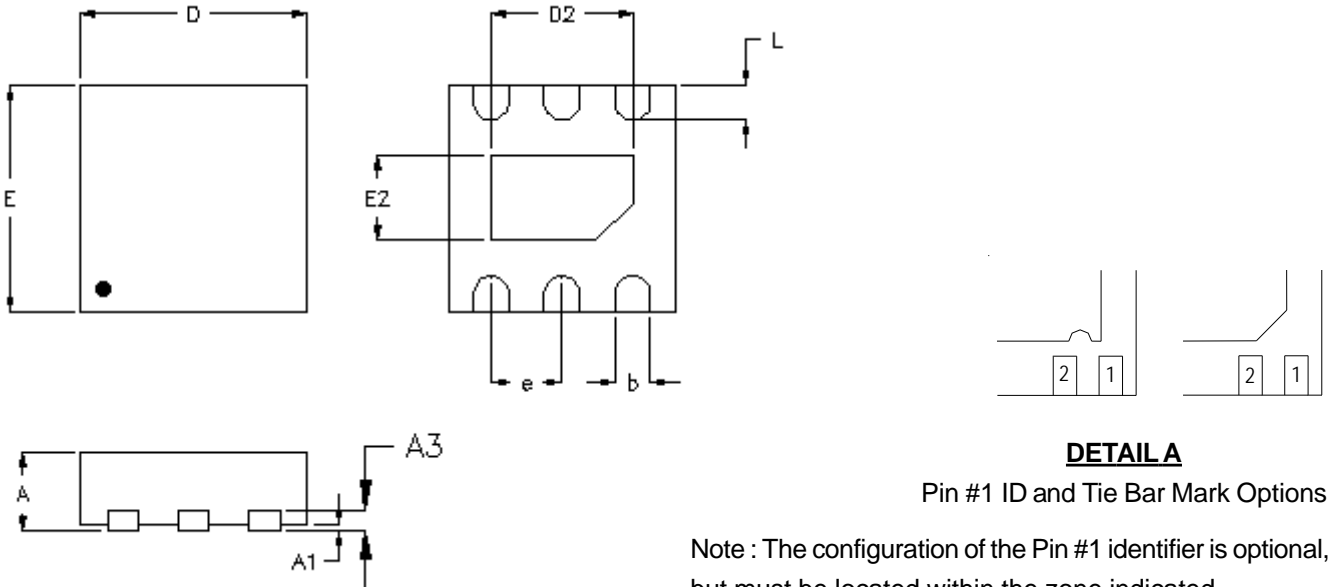

Figure 4. PCB Layout Guide

Outline Dimension



DETAIL A

Pin #1 ID and Tie Bar Mark Options

Note : The configuration of the Pin #1 identifier is optional, but must be located within the zone indicated.

Symbol	Dimensions In Millimeters		Dimensions In Inches	
	Min.	Max.	Min.	Max.
A	0.500	0.600	0.020	0.024
A1	0.000	0.050	0.000	0.002
A3	0.100	0.175	0.004	0.007
b	0.200	0.300	0.008	0.012
D	1.500	1.700	0.059	0.067
D2	0.950	1.050	0.037	0.041
E	1.500	1.700	0.059	0.067
E2	0.550	0.650	0.022	0.026
e	0.500		0.020	
L	0.200	0.300	0.008	0.012

U-Type 6L DFN 1.6x1.6 Package

Richtek Technology Corporation

14F, No. 8, Tai Yuen 1st Street, Chupei City
 Hsinchu, Taiwan, R.O.C.
 Tel: (8863)5526789

Richtek products are sold by description only. Richtek reserves the right to change the circuitry and/or specifications without notice at any time. Customers should obtain the latest relevant information and data sheets before placing orders and should verify that such information is current and complete. Richtek cannot assume responsibility for use of any circuitry other than circuitry entirely embodied in a Richtek product. Information furnished by Richtek is believed to be accurate and reliable. However, no responsibility is assumed by Richtek or its subsidiaries for its use; nor for any infringements of patents or other rights of third parties which may result from its use. No license is granted by implication or otherwise under any patent or patent rights of Richtek or its subsidiaries.

单击下面可查看定价，库存，交付和生命周期等信息

[>>Richtek\(台湾立锜\)](#)